



LIFETIME

kompostér PREMIUM



model 60028

návod na montáž a údržbu

Pro pomoc s montáží nebo objednání náhradních dílů volejte náš český HOT LINE 739-661-428

Bezpečnostní pokyny

- **Důležité! Před montáží si nejdříve až do konce přečtěte tento manuál.**
- Zkontrolujte si ihned po převzetí produktu, zda balení obsahuje všechny části a součástky.
- Před tím, než začnete kompostér stavět, si rozdělte a identifikujte všechny části a součástky pomocí seznamu částí v tomto dokumentu. Pokud nějaký díl chybí, **kompostér nestavte** a kontaktujte náš HOT LINE.
- Při montáži používejte ochranné pomůcky a dodržujte předpisy bezpečnosti práce.
- Správná a úplná montáž, užití a kontrola jsou důležité ke snížení rizika nehody nebo poranění.
- Kompostér je možné používat pouze jako kompostér. Jakékoliv jiné použití je v rozporu s návodem na použití a výrobce v tomto případě neručí za bezpečnost výrobku.
- Řiďte se pečlivě všemi upozorněními a výstrahami.
- Kompostér musí být postaven na rovném povrchu.
- Během sezóny i před ní kontrolujte, zda jsou veškeré spoje dostatečně utažené.
- Většina poranění je způsobena špatným použitím a/nebo nedodržením pokynů v manuálu. Dbejte pokynů při používání tohoto výrobku.
- Kompostér nesmí obsluhovat nebo jinak užívat děti !! Nebezpečí poranění.

Čištění a údržba

Pokud budete dodržovat následující instrukce, bude vám výrobek sloužit mnoho let k vaší spokojenosti. Panely z polyetylenu jsou odolné vůči nečistotám a rozpouštědlům. Většinu nečistot lze odstranit jemným mýdlovým roztokem a měkkou houbičkou. Drsné čisticí materiály by mohly plasty poškrábat, proto nejsou doporučovány. Velice jemným smirkovým papírem lze opravit škrábance nebo koroze na kovu, použijte ochranný sprej proti rzi jako podklad a nakonec použijte bezbarvý lak ve spreji s vysokým leskem.

Nepoužívejte a ani neskladujte zdroje tepla uvnitř nebo poblíž kompostéru.

Prodloužená smluvní záruka

Výrobce si vyhrazuje právo na změnu reklamace, jestliže budou části nedostupné nebo zastaralé.

1. Výrobce poskytuje původnímu kupujícímu prodlouženou smluvní záruku na kompostéry po dobu 5 let od data nákupu. Defekty jsou definovány jako závada, která omezuje použití produktu. Defekty způsobené nesprávným použitím nebo nedbalostí do záruky nespádají. Záruku není možné uplatnit ani na defekty způsobené nesprávnou instalací, úpravami nebo nehodami. Také ji nelze použít v případě poškození způsobené vandaly, korozí, „vyšší mocí“, pojistnou událostí nebo jinými událostmi mimo kontrolu továrny.
2. Tato záruka je nepřenositelná a je výslovně omezená k opravě nebo výměně poškozeného produktu. Pokud je výrobek poškozen v termínu záruky, výrobce opraví nebo vymění poškozené části zdarma. Náklady na odeslání z a do prodejny v tom zahrnuté nejsou a je to na odpovědnosti kupujícího. Práce a podobné výlohy na přepravu, instalaci nebo výměnu výrobku nebo jeho částí nejsou zahrnuté do záruky.
3. Do záruky není zahrnuto poškrábání nebo odření výrobku při běžném používání. Navíc nejsou do záruky zahrnuté defekty vyplývající z úmyslného poškození, nedbalosti, nerozumným užíváním.
4. Zodpovědnost za náhodné nebo následné škody je vyloučena v rozsahu povoleným zákonem. Ačkoli je celé příslušenství vyrobeno s nejvyšším stupněm bezpečnosti, nelze vyloučit možnost poranění. Uživatel přebírá zodpovědnost za veškerá nebezpečí úrazu, plynoucí z užívání tohoto produktu.
5. Tento produkt není určen pro komerční účely, výrobce při takovém užití nepřebírá zodpovědnost. Komerční používání povede ke zrušení záruky.

BEZPEČNOSTNÍ UPOZORNĚNÍ:

Upozorňujeme na fakt, že v ojedinělých případech (stejně jako při jakémkoliv jiném kompostovacím procesu) může v extrémních případech dojít biologickému zahoření obsahu kompostéru. Vzniká tak riziko potencionálního požáru kompostéru, případně okolí.

Umístěte proto raději kompostér na takovém bezpečném místě, kde ani v případě biologického zahoření (naprosto ojedinělá, ale možná situace) nevznikne riziko škody.

Biologické zahoření je fyzikálním jevem, který výrobce nemůže nijak ovlivnit ani mu nijak předejít. Za případné škody vzniklé biologickým zahořením, tak výrobce ani prodejce nemohou zodpovídat.



SAFETY INSTRUCTIONS



FAILURE TO FOLLOW THESE WARNINGS MAY RESULT IN SERIOUS INJURY OR PROPERTY DAMAGE AND WILL VOID WARRANTY.

To ensure safety, do not attempt to assemble this product without following the instructions carefully. Check entire box and inside all packing material for parts and/or additional instruction material. Before beginning assembly, read the instructions and identify parts using the hardware identifier and parts list in this document. Proper and complete assembly, use and supervision are essential to reduce the risk of accident or injury.

- Two capable adults are required for assembly.

Most injuries are caused by misuse and/or not following instructions. Use caution when using this product.



INSTRUCCIONES DE SEGURIDAD



EL INCUMPLIMIENTO DE SEGUIR ESTAS ADVERTENCIAS PUEDE RESULTAR EN LAS LESIONES GRAVES O EL DAÑO A LA PROPIEDAD Y ANULARÁ LA GARANTÍA.

Para asegurar la seguridad, no intente de armar este producto sin seguir detenidamente las instrucciones. Inspeccione la caja entera y toda la materia de embalaje para las partes y/o materia adicional. Antes de comenzar el armado, lea las instrucciones e identifique las partes usando el Identificador del herraje y la Lista de piezas en este documento. El armado propio y completo, el uso y la supervisión son esenciales para la orientación propio y para reducir el riesgo de accidentes y lesiones.

- Dos adultos competentes son requeridos para este armado.

La mayoría de las lesiones son causadas por el uso erróneo y/o el incumplimiento de seguir las instrucciones. Tenga cuidado al usar este cobertizo.



INSTRUCTIONS DE SÉCURITÉ



LA NON-OBSERVATION DE CES AVERTISSEMENTS PEUT ENTRAÎNER EN CONSÉQUENCE DES BLESSURES SÉRIEUSES OU L'ENDOMMAGE À LA PROPRIÉTÉ ET ANNULERA LA GARANTIE.

Pour assurer votre sécurité, n'attendez pas de monter cet élément sans suivre attentivement les instructions. Vérifiez les boîtes entières et l'intérieur de tout le matériel pour les pièces et/ou matériel d'instruction additionnel. Avant de commencer le montage, lisez les instructions et identifiez les pièces en utilisant l'Identificateur d'accessoires et la Liste de pièces dans ce document. Le montage propre et complète et la supervision sont essentiels pour réduire le risque des hasards ou des blessures.

- Deux adultes capables sont requis pour monter cet élément.

La plupart des blessures sont causées par l'abus et/ou par ne suivre les instructions. Faites attention lorsque vous utilisiez cet abri.



INSTRUÇÕES DE SEGURANÇA



DEIXAR DE SEGUIR ESTAS ADVERTÊNCIAS PODERÁ PROVOCAR LESÕES GRAVES OU DANOS À PROPRIEDADE E ANULARÁ A GARANTIA.

Para manter a segurança, não tente montar este sistema sem seguir atentamente as instruções. Inspeccione toda a caixa e o conteúdo do material de embalagem para localizar as peças e/ou materiais com instruções adicionais. Antes de iniciar a montagem, leia as instruções e identifique as peças usando o identificador das ferragens e a lista de peças existentes neste documento. O uso, a montagem, e a supervisão adequados e completos são fundamentais para diminuir o risco de acidente ou lesão. Existe uma grande probabilidade de lesão grave se não se montar, mantiver e operar este sistema de modo adequado.

- Recomenda-se a participação de dois adultos capacitados na montagem.

A maioria das lesões decorre do uso inadequado e/ou de não seguir as instruções. Tome cuidado ao usar este sistema.



SICHERHEITSINFORMATIONEN



WENN DIESE WARNUNGEN NICHT BEFOLGT WERDEN, KANN ES ZU SCHWERWIEGENDEN VERLETZUNGEN ODER SACHSCHÄDEN KOMMEN UND DIE GARANTIE WIRD AUSSER KRAFT GESETZT.

Um Ihre Sicherheit zu gewährleisten, sollten Sie nicht versuchen, das Produkt aufzubauen, ohne dabei die Anleitungen sorgfältig zu befolgen. Suchen Sie in der gesamten Kiste und in dem Verpackungsmaterial nach Teilen und/oder zusätzlichen Anleitungen. Bevor Sie mit der Montage beginnen, lesen Sie bitte alle Anleitungen und identifizieren die Teile aufgrund der Eisenwarenliste und der Stückliste in diesem Dokument. Der korrekte und vollständige Zusammenbau sowie der korrekte Gebrauch und die richtige Kontrolle ist dabei ausschlaggebend, das Unfallrisiko und Verletzungsrisiko zu reduzieren.

- Für die Montage werden zwei fähige Erwachsene benötigt.

Die meisten Unfälle passieren durch den Fehlgebrauch und das Nichtbefolgen der Anleitungen. Seien Sie vorsichtig, wenn Sie dieses Produkt benutzen.



VEILIGHEIDSAANWIJZINGEN



ALS U VERZUIMT DEZE WAARSCHUWINGEN IN ACHT TE NEMEN, ZIJN ERNSTIG LETSEL EN/OF SCHADE AAN EIGENDOM MOGELIJK; VERDER KOMT IN DIT GEVAL DE GARANTIE TE VERVALLEN.

Belangrijke veiligheidsaanwijzing: bij het in elkaar zetten van dit product moeten alle aanwijzingen nauwgezet worden nagevolgd. Controleer de hele doos en alle verpakkingsmaterialen op onderdelen en/of verdere aanwijzingen. Alvorens te beginnen met het in elkaar zetten, wordt u geacht de aanwijzingen te lezen en de diverse onderdelen te identificeren aan de hand van de identificatielijst voor bevestigingsmaterialen en de onderdelenlijst die deel uitmaken van dit document. Teneinde het risico van ongelukken of letsel te verlagen, is het van essentieel belang dat de berging juist en volledig in elkaar wordt gezet en gebruikt en dat hierbij voldoende supervisie wordt geboden.

- Voor het in elkaar zetten van de systeem zijn twee competente volwassenen nodig.

Als mensen zich bezeren, komt dit meestal door verkeerd gebruik en/of het niet opvolgen van de aanwijzingen. Ga altijd uiterst voorzichtig te werk bij het gebruik van dit product.



安全の手引き



以下の警告に従わなければ、深刻なケガまたは物的損害が生じ、保証が無効になる場合があります。

安全を保証するため、すべての説明をお読みになっていない状態で指示に従わずに本製品を組み立てようとししないでください。部品や追加の説明書が入っていないか、箱全体とあらゆる梱包資材の中をチェックしてください。組立てを開始する前に、本書内の部品およびハードウェア・リストおよび識別記号を使用して、すべての部品とハードウェアが揃っていることを確認してください。適切な設置、そして事故またはケガの危険性を軽減するためには、正しく完全な組立て、使用、および監督が不可欠です。この製品が適切に取付け、維持および/または管理されない場合、高い確率で深刻なケガが発生します。本説明書に記載されている警告に従わない場合、切り傷、骨折、神経損傷、麻痺、脳損傷、または死などの深刻な身体傷害が生じる場合があります。また、警告に従わない場合は、物的損害が生じる可能性もあります。すべての警告と注意をよくお読みください。

- の組立てには、2人の作業可能な大人が必要です。

ほとんどのケガは、誤用や指示に従わないことが原因で発生します。本製品を使用するときは、十分注意を払ってください。



안전지침



아래의 경고사항들을 따르지 않으시면 심각한 부상 또는 자산의 손상을 입을 수도 있으며 보증은 무효가 될 것입니다.

안전을 위해, 이 제품의 조립 시에는 지침을 주의 깊게 따르십시오. 부품 및/또는 부가적인 지침 자료를 전체 박스와 모든 포장 자재의 내부에서 확인하십시오. 조립을 시작하시기 전에, 지침을 읽으시고 이 자료에 수록된 하드웨어 확인항목 및 부품 리스트를 이용해서 부품들을 확인하십시오. 사고 또는 부상의 위험을 줄이기 위해서는 적절하고 완전한 조립, 사용과 감독이 필수적입니다.

- 조립을 마무리하려면 두 명의 성인이 필요합니다.

대부분의 부상은 지침을 잘못 사용하거나/또는 따르지 않아 비롯됩니다. 이 제품을 사용하실 때는 주의를 기울이십시오.



安全說明



不遵守這些警告可能會導致嚴重傷害或財產損失並且將喪失保固

為了保障您的安全，請不要嘗試在沒有小心遵守說明步驟的情況下進行組裝。檢查整個箱子及內含所有包裝中的零件和(或)附加的說明元件。在開始組裝之前，詳讀說明及使用本文件中的配件辨識與零件清單來確認零件。正確和完整的組裝，正確使用方向和監督是必不可少的，以及減少事故危險或傷害。如果這個裝置沒有安裝，維修和(或)操作正常是有發生嚴重傷害的高風險可能。

- 建議由兩名有成人能力者進行組裝。

大多數傷害是由於誤用和(/或)不遵守指示。 使用使用這個裝置時要小心。

****U.S. and Canada customers ONLY****

IF ASSISTANCE IS NEEDED, DO NOT CONTACT THE STORE!

CALL OUR CUSTOMER SERVICE DEPARTMENT at 1 (800) 225-3865

HOURS: 7:00 a.m. to 5:00 p.m. Monday through Friday (Mountain Standard Time)

Call, or visit our Web site for Saturday hours

For customers outside the U.S. or Canada, please contact the store for assistance.

****Clientes de los E.U.A. o de Canadá SOLAMENTE****

SI NECESITA ASISTENCIA, ¡NO CONTACTE LA TIENDA!

LLAME A NUESTRO DEPARTAMENTO DE SERVICIOS A CLIENTES AL 1.800.225.3865

HORAS: 0700 - 1700 Lunes a viernes (HNR)

Llame, o visite nuestra página en Internet para las horas de sábado

Para los clientes afuera de los Estados Unidos o de Canadá, póngase en contacto con la tienda por favor.

****Clients des États-Unis et du Canada SEULEMENT****

SI VOUS AVEZ BESOIN D'ASSISTANCE, NE CONTACTEZ PAS LE MAGASIN !

APPELEZ NOTRE DÉPARTEMENT DE SERVICE À LA CLIENTÈLE AU 1.800.225.3865

HEURES: 0700 - 1700 lundi - vendredi (HNR)

Appelez, ou rendez-vous une visite à notre site Web pour obtenir les heures de samedi

Clients au-dehors des États-Unis ou du Canada, veuillez contacter le magasin pour obtenir assistance.



1(800)225-3865

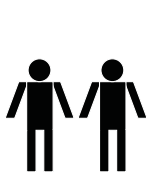
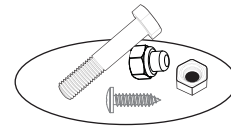
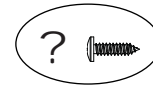
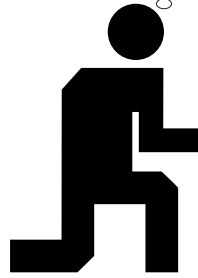

+

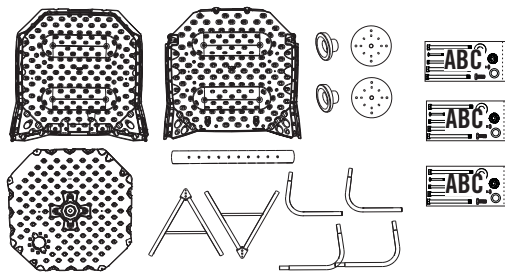

=

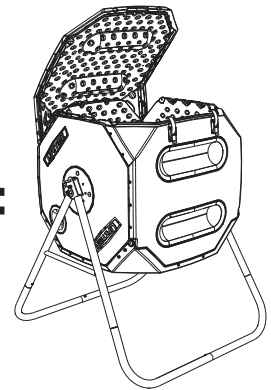

REQUIRED TOOLS / HERRAMIENTAS REQUERIDAS / OUTILS REQUIS / FERRAMENTAS NECESSÁRIAS / BENÖTIGTE WERKZEUGE / BENODIGD GEREEDSCHAP / 必要工具 / 필수장비들 / 組裝所需的工具

3/4" (19,1 mm) 7/16" (11,1 mm)



(1)



(1)



(1)

1/2" (12,7 mm) & 3/4" (19,1 mm)



(1)



(1)



(1)

3/16" (4,8 mm)

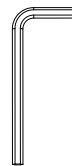

(1)

1/8" (3,2 mm)



(1)



(2)

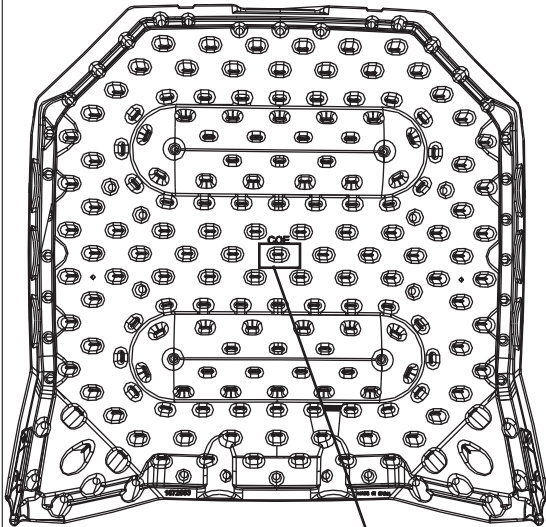

COE (x2)

COE

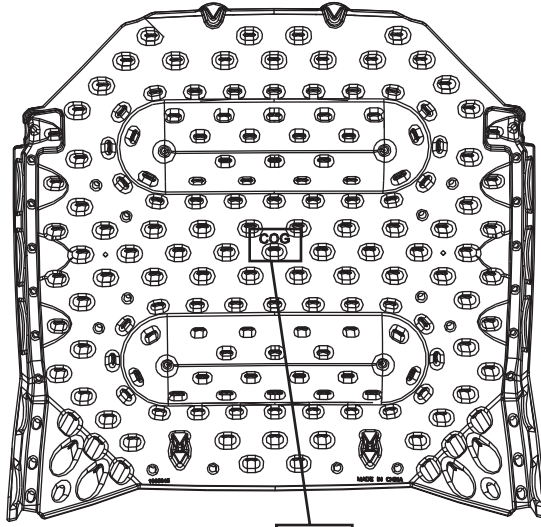

COG (x2)

COG

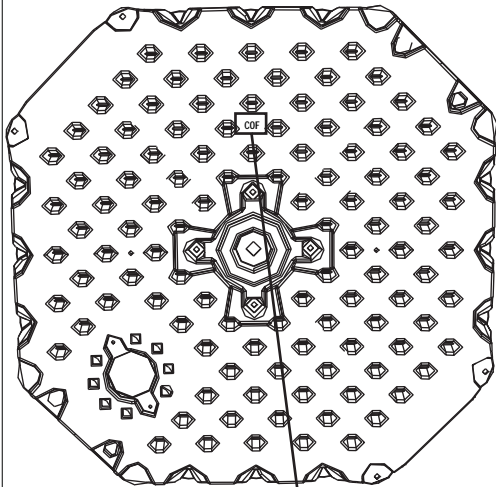

COF (x2)

COF

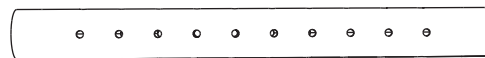

BHQ (x1)

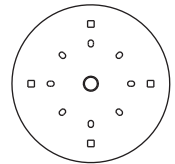

BHP (x2)

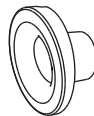

COH (x2)

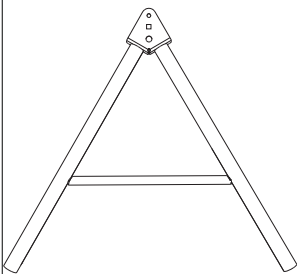

BII (x2)

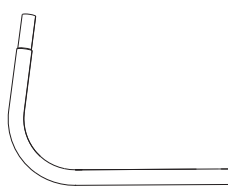

COQ (x2)

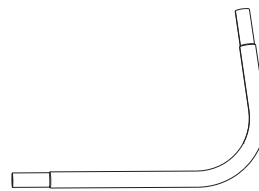

COP (x2)





BIN (x1)

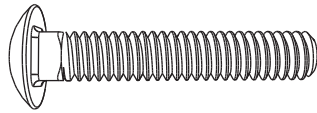

ABU (x2)

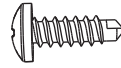

BHJ (x6)



ADJ (x2)

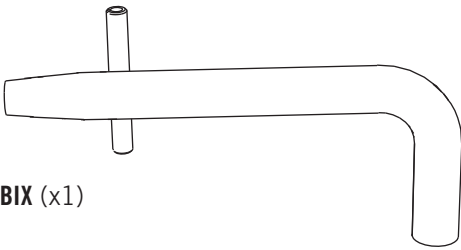
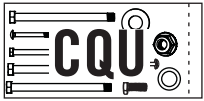

BIX (x1)

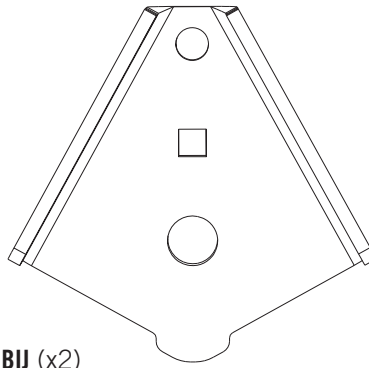

BIJ (x2)

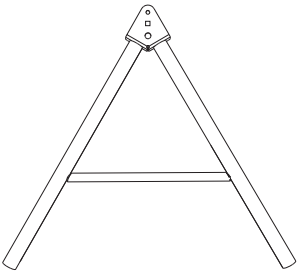

BII (x2)

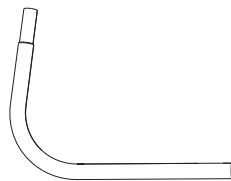

COQ (x2)

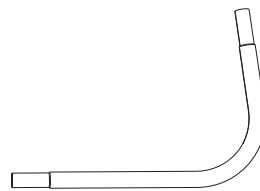

COP (x2)



7/16" (11,1 mm)





BHJ (x6)

BIN (x1)

BIX (x1)

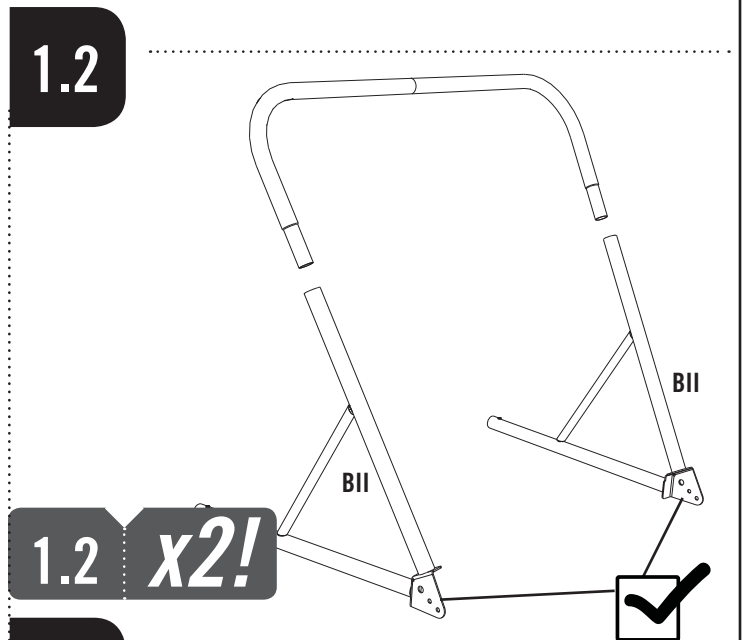
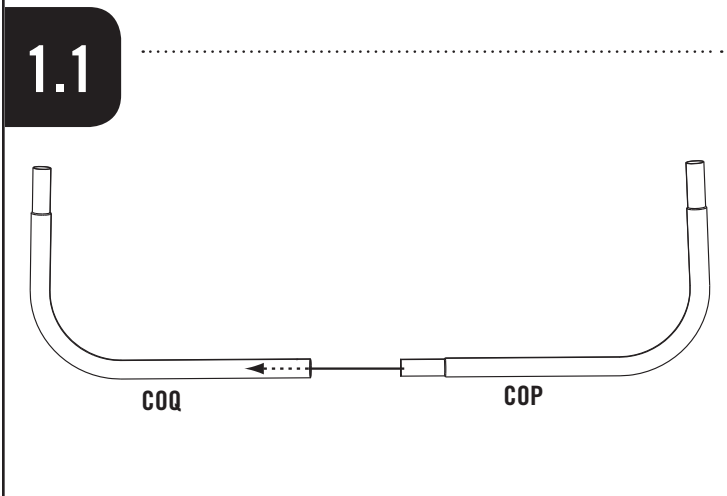
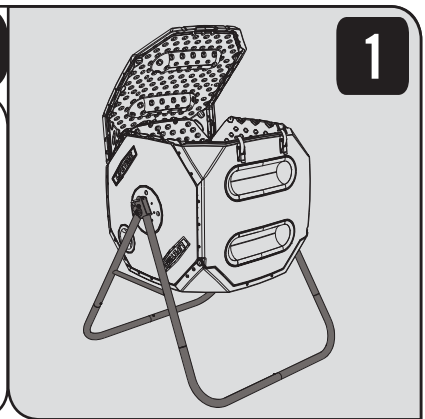

1.1 x2!

1.2 x2!

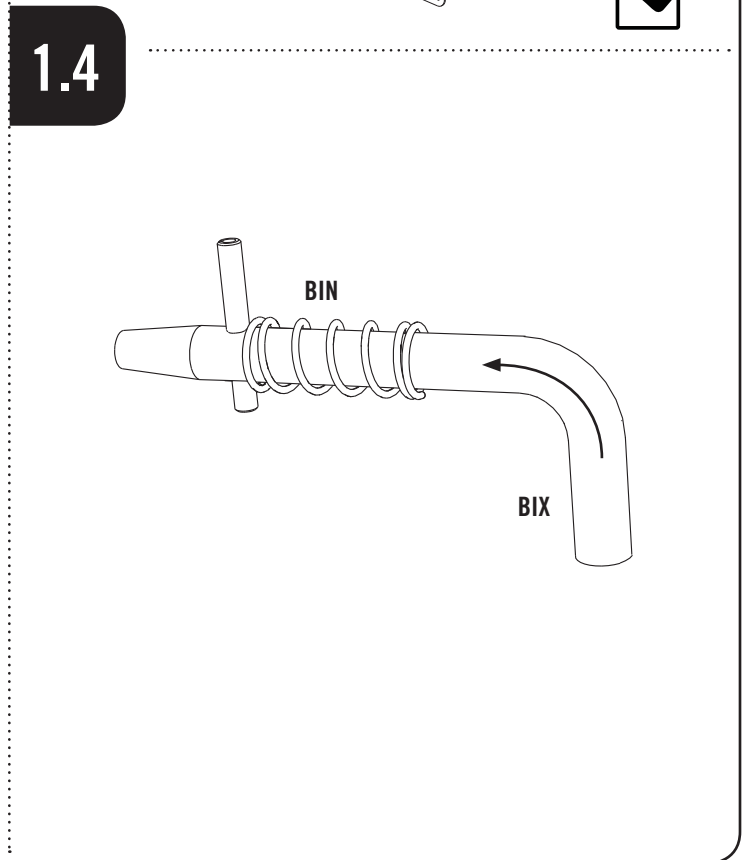
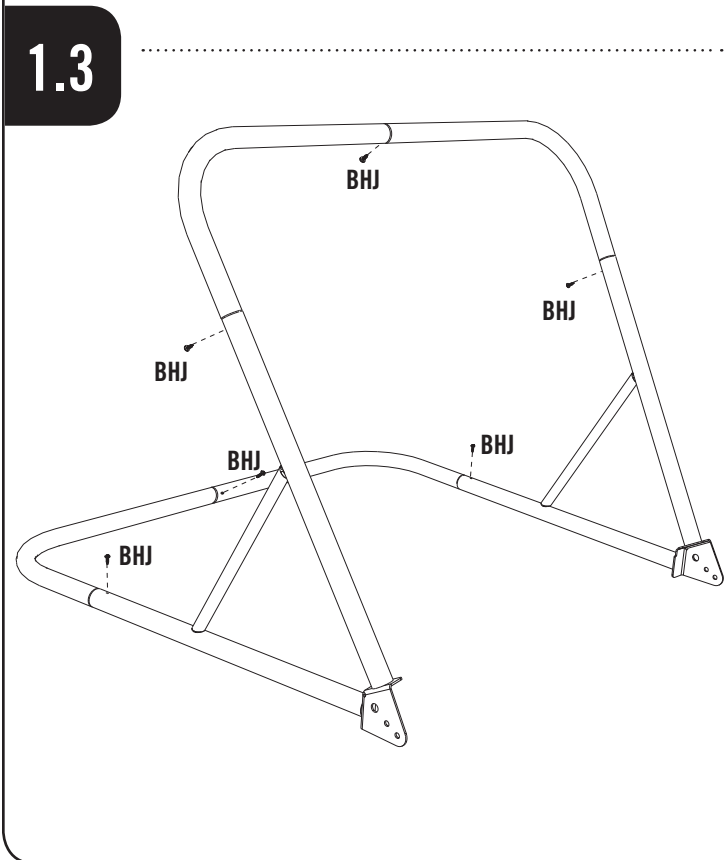

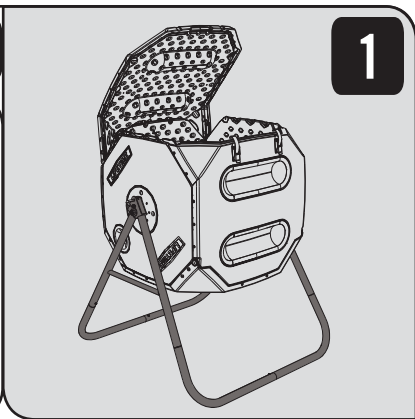

1

7/16"
(11,1 mm)

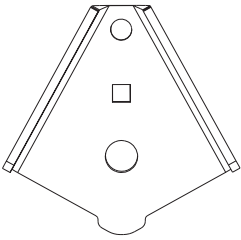
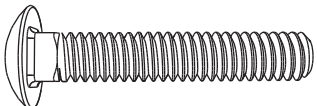
ABU (x2)



ADJ (x2)

BIJ (x2)

1.5

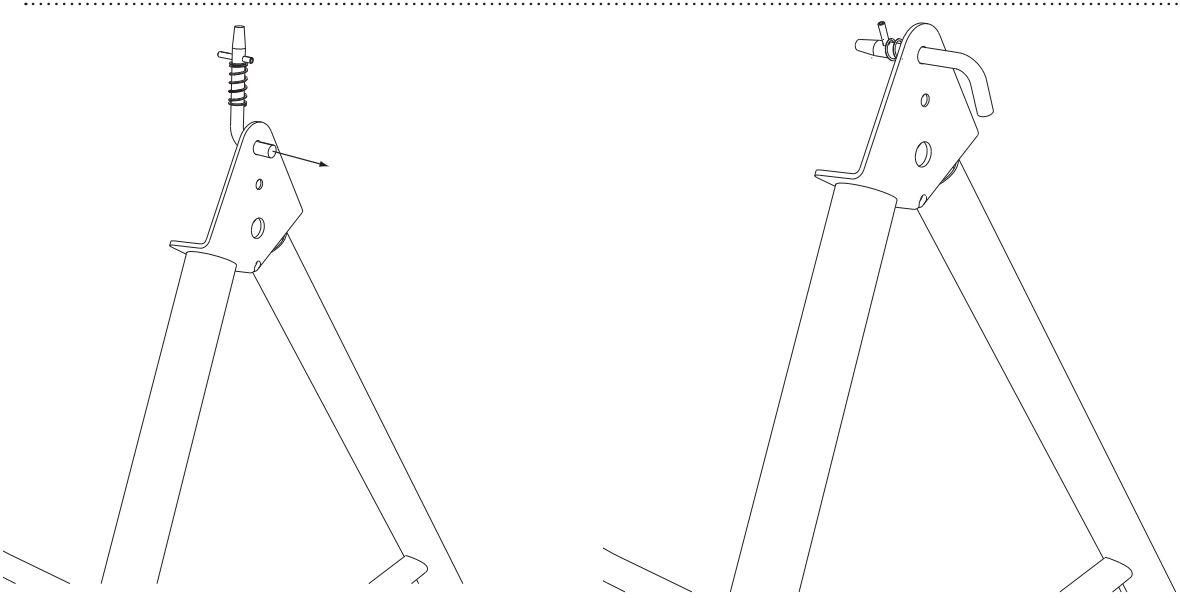

1.6

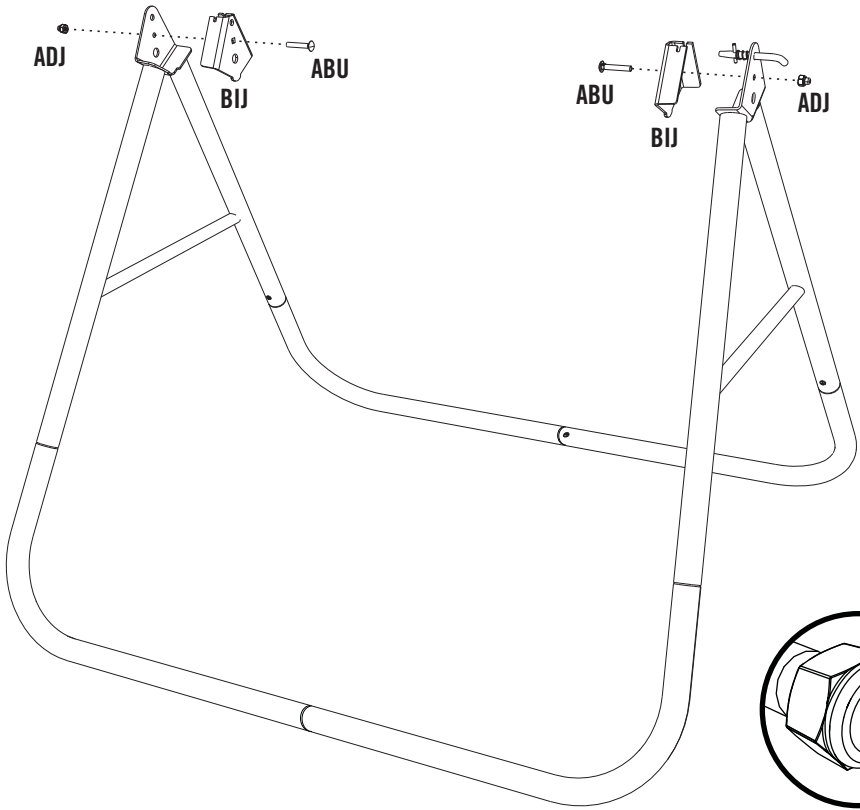

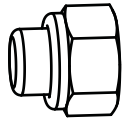

AAN (x16)

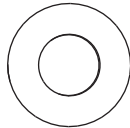

BHO (x16)

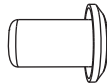

BTK (x12)

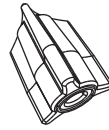

BHK (x36/38)

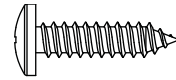

ADW (x36/38)

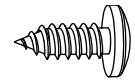

ADX (x8)

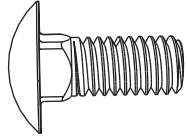

BIR (x8)

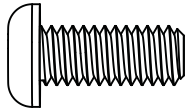

AWU (x8)

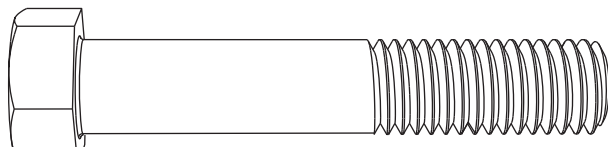

BIK (x2)

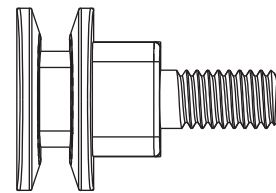

COK (x4)

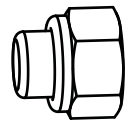

AAN (x4)

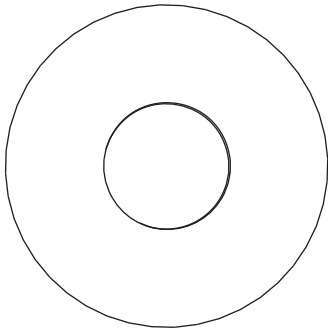

BIP (x2)

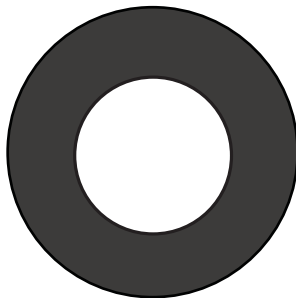

BIM (x2)

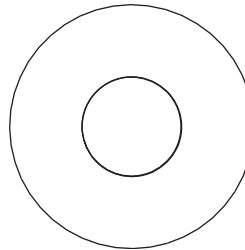

BIO (x4)

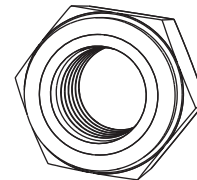

ADM (x2)

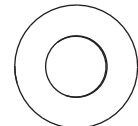

BHO (x4)

CCL (x1)

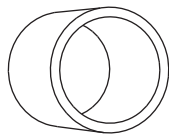

BIL (x2)

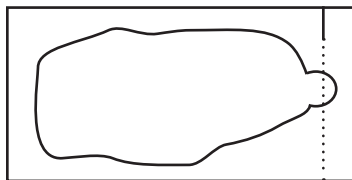

AKH (x1)

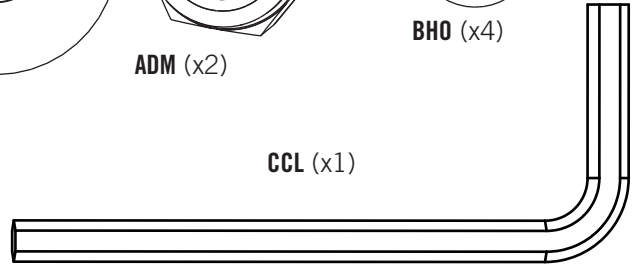

ARA (x1)

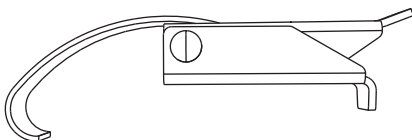

COL (x2)

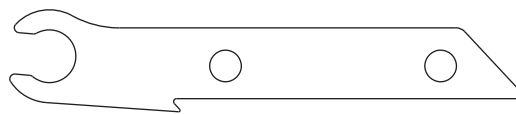

COM (x4)

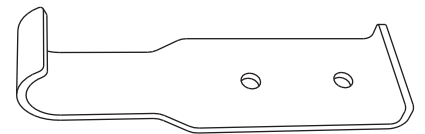

CON (x2)

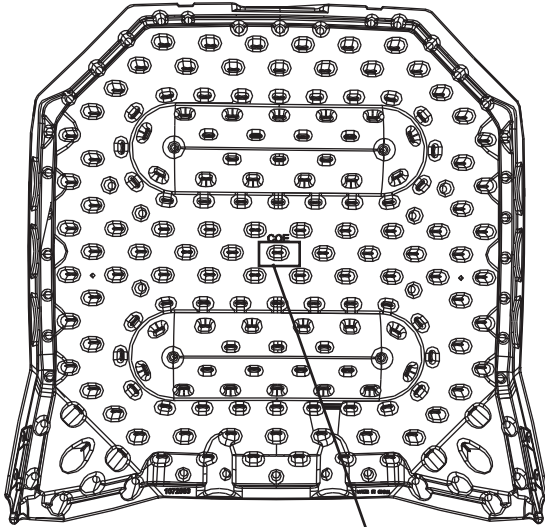

COE (x2)

COE

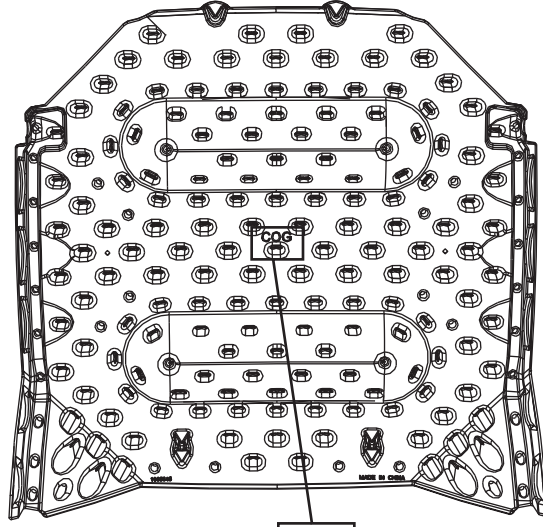

COG (x2)

COG

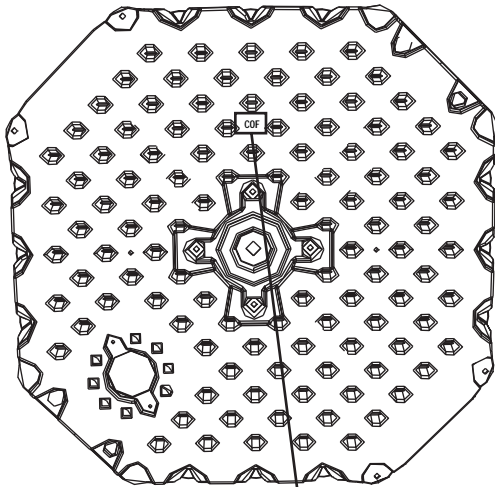

COF (x2)

COF



COH (x2)

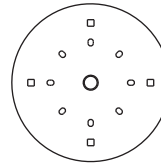

BHP (x2)

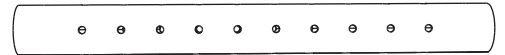

BHQ (x1)



3/4" (19,1 mm)



1/2" (12,7 mm) & 3/4" (19,1 mm)



(ARA) 1/8" (3,2 mm)



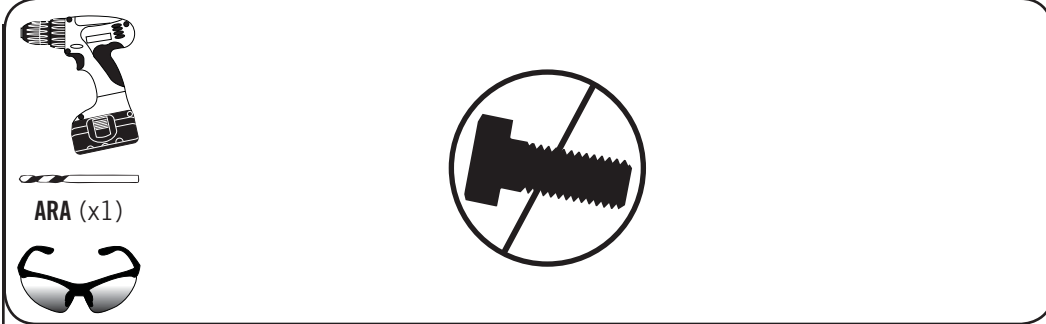
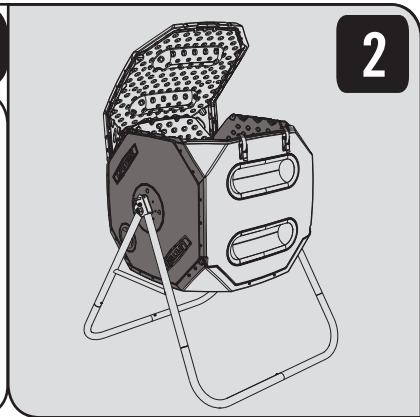

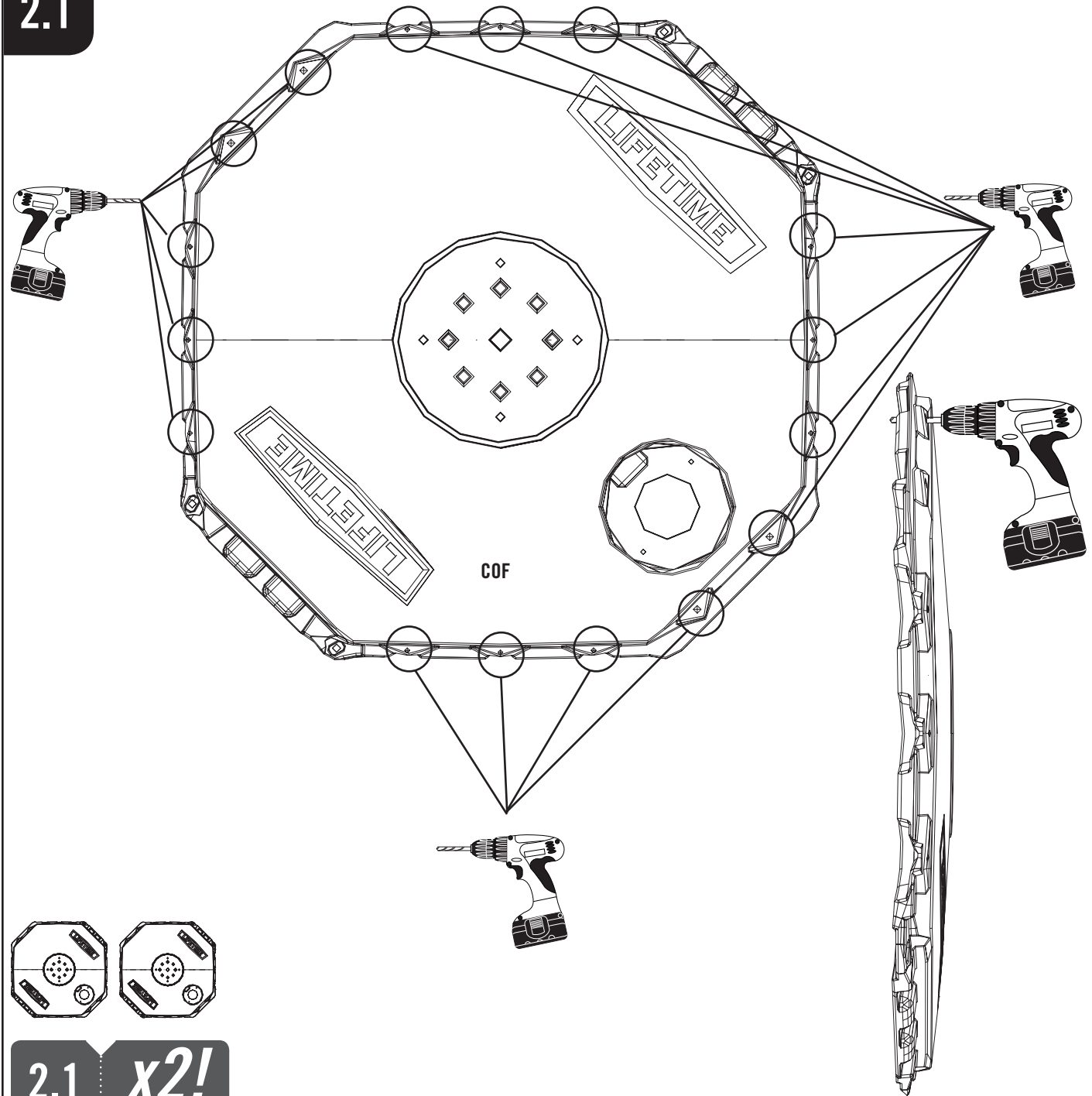

2.1



2.1 x2!

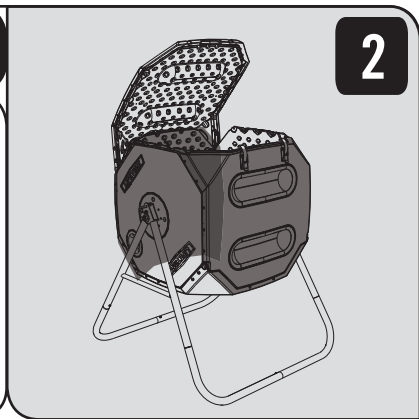

2



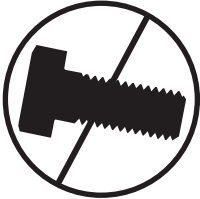

ARA (x1)



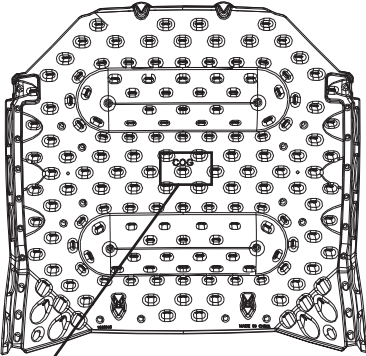

2.2

COG (#1 & #2)

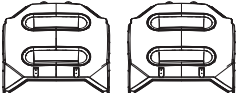
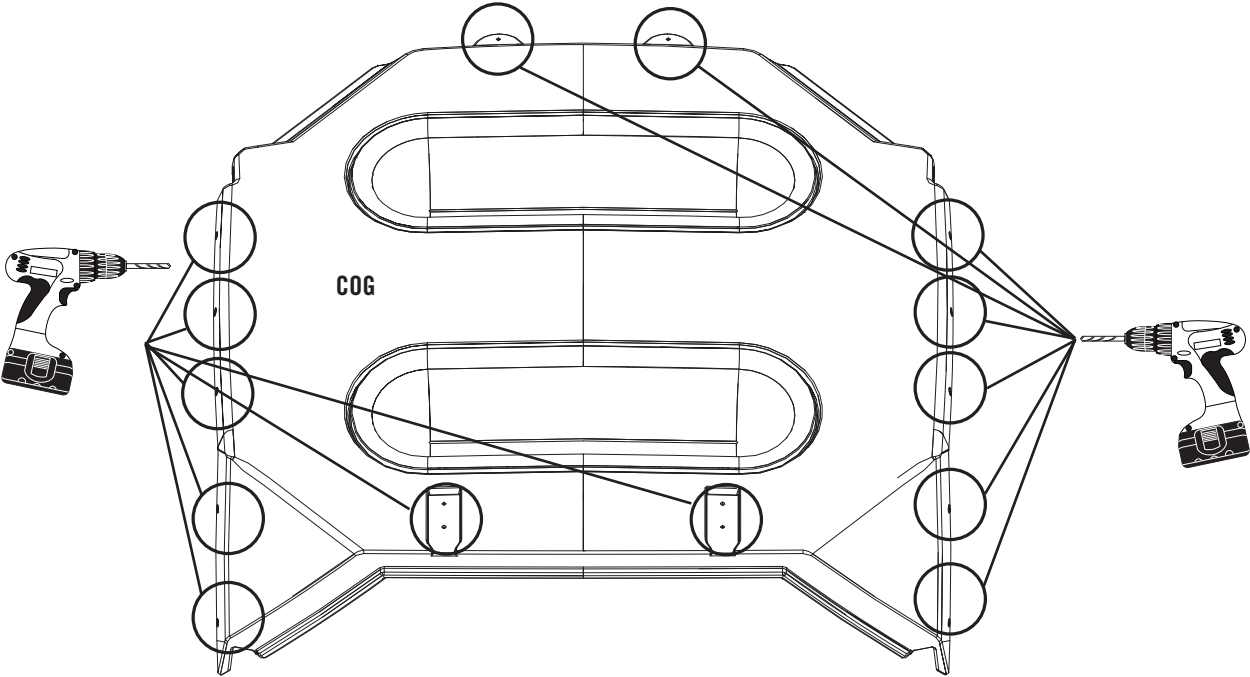

COG



COG x2!

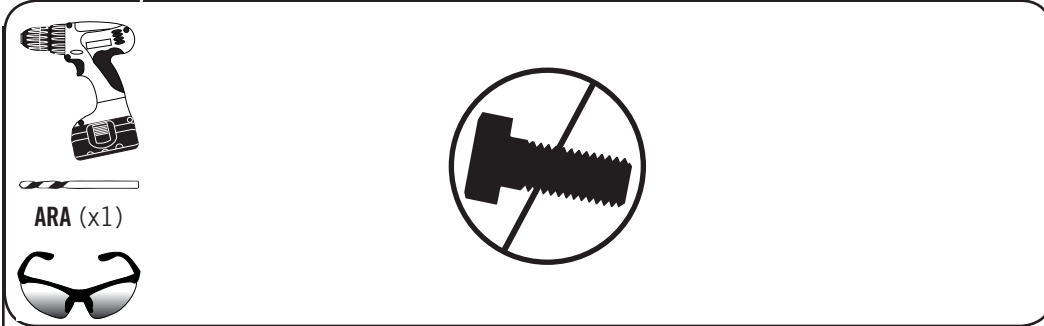
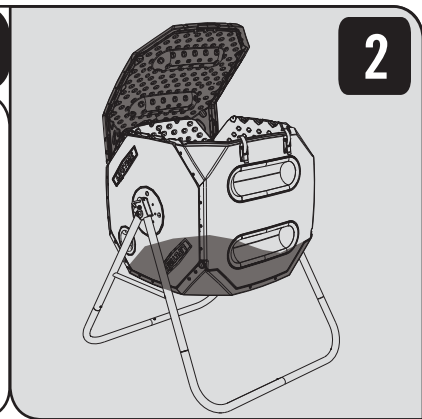

2.3

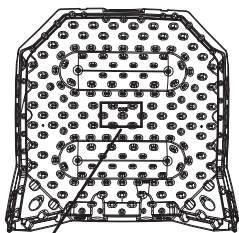

COE (#1)

COE

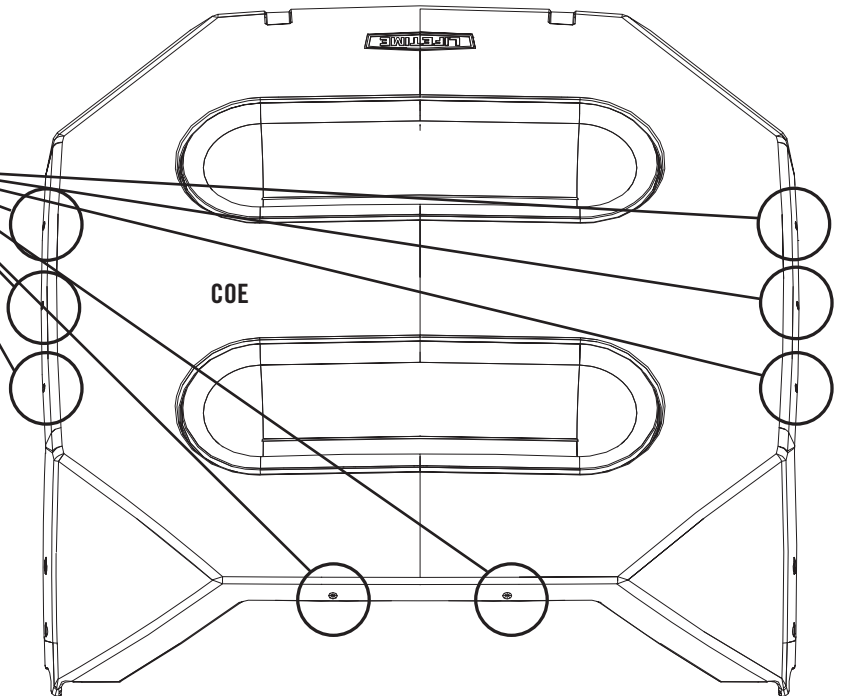
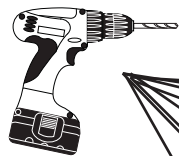

COE

COE (#2)

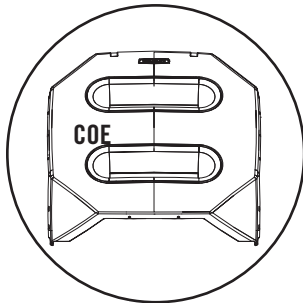

- Drill through only one of these Panels (COE). The second Panel will be the Lid.
- Taladrar a través un Panel (COE) solamente. El segundo Panel será la Tapa.
- Ne percer qu'un Panneau (COE). Le deuxième Panneau sera le Couverture.
- Perfurar apenas um Painel (COE). O segundo Painel será a Tampa.
- Bohren durch nur eine dieser Paneele (COE). Das zweite Paneel wird der Deckel werden.
- Boor door slechts een van deze panelen (COE). Het tweede paneel zal de deksel worden.
- これらのパネルの1つだけ(COE)ドリルスルー。番目のパネルは、コンポスターのフタになります。



2

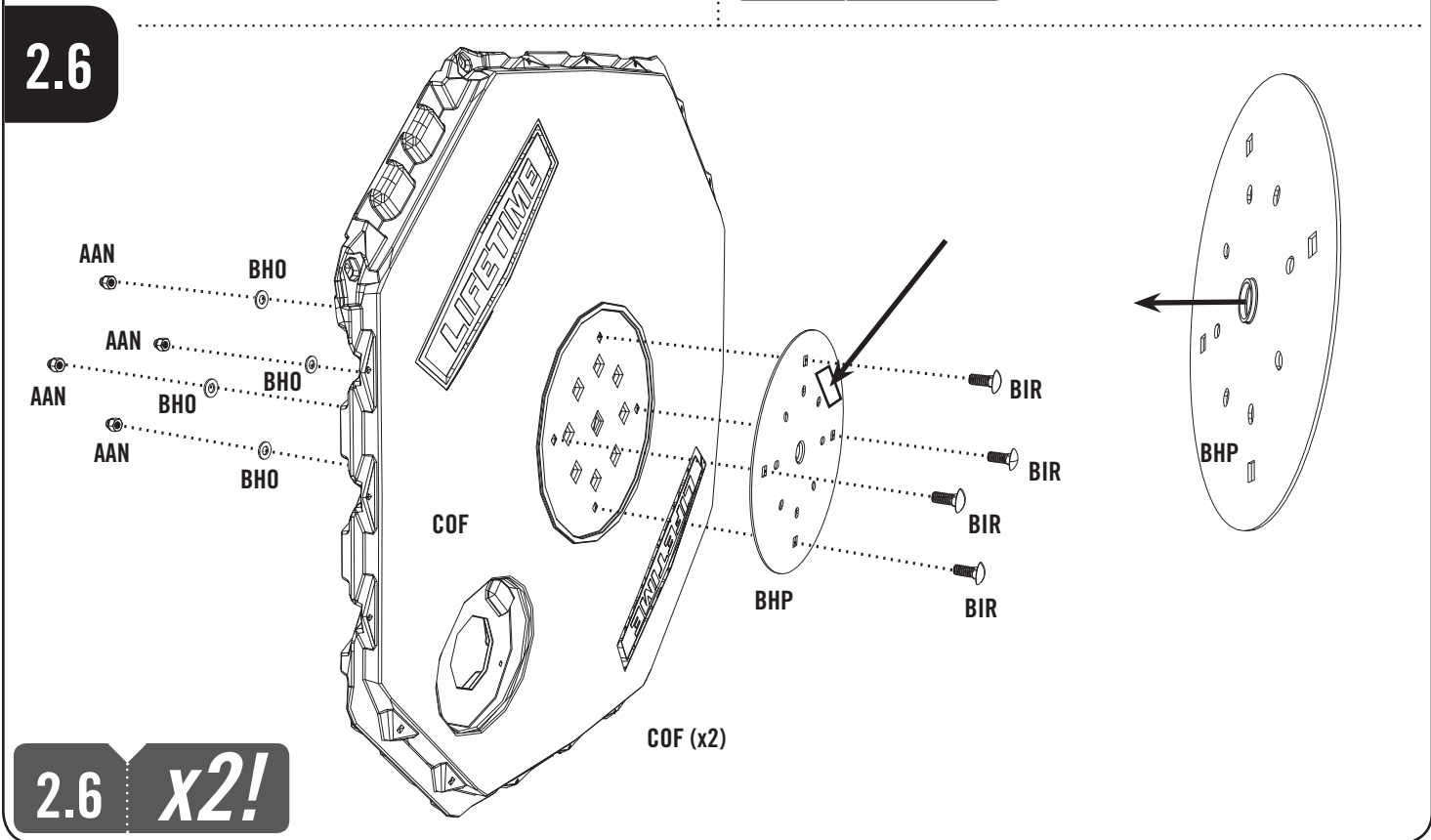
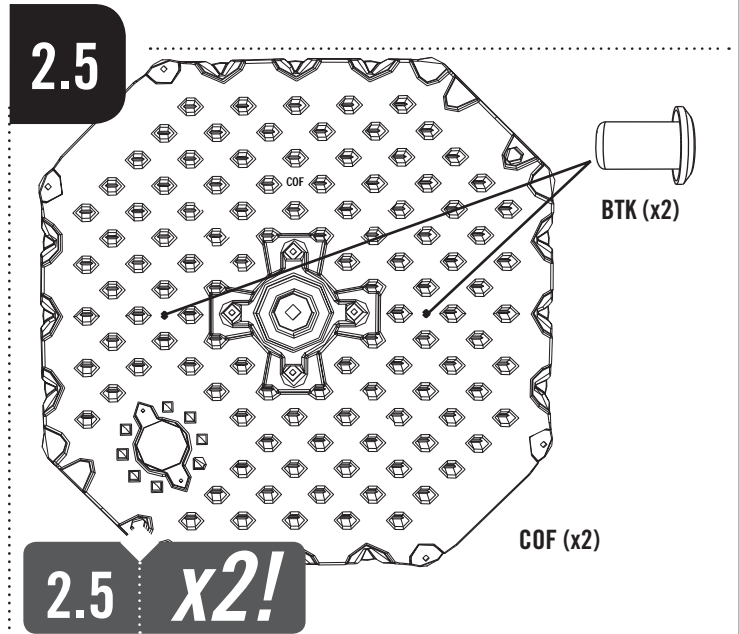
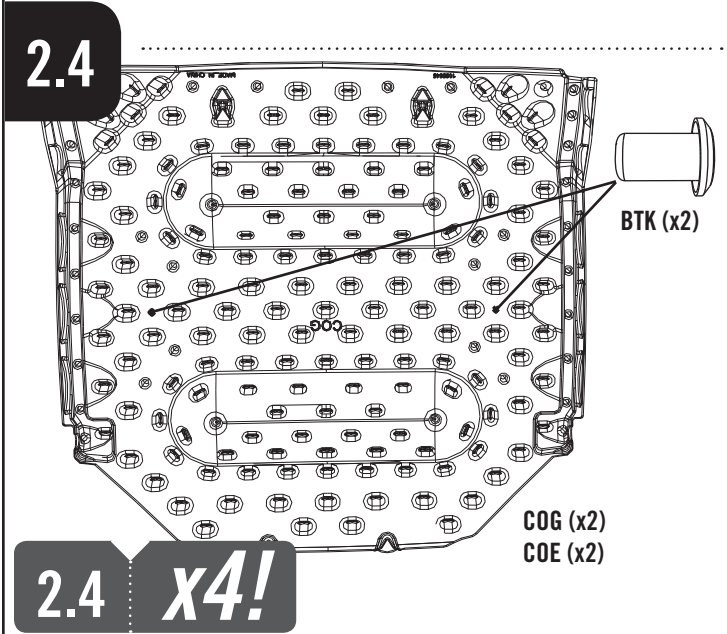
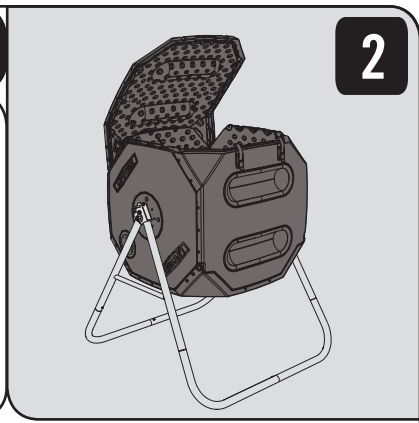
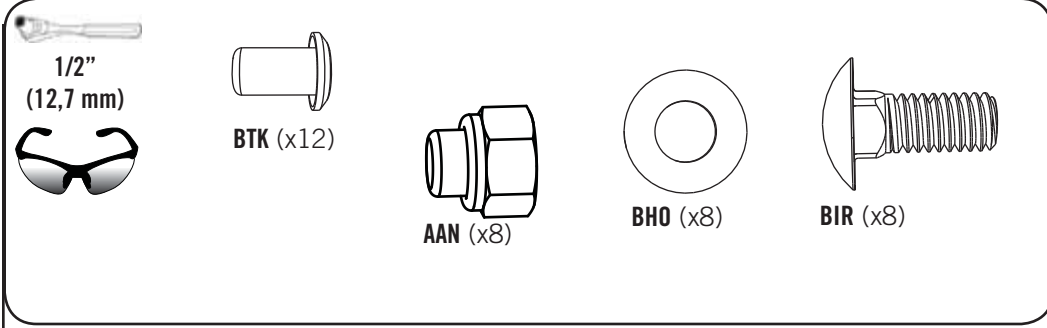

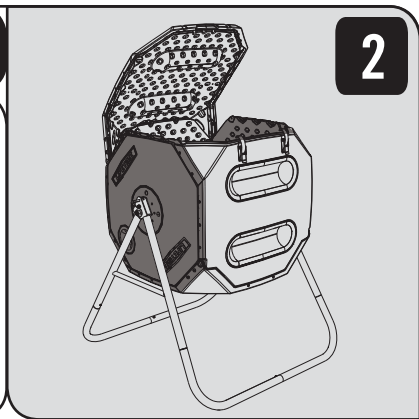

1/2"
(12,7 mm)

COK (x4)

BHO (x4)

AAN (x4)

2.7

COF #1

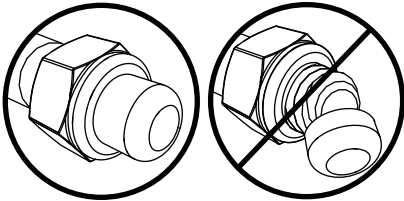
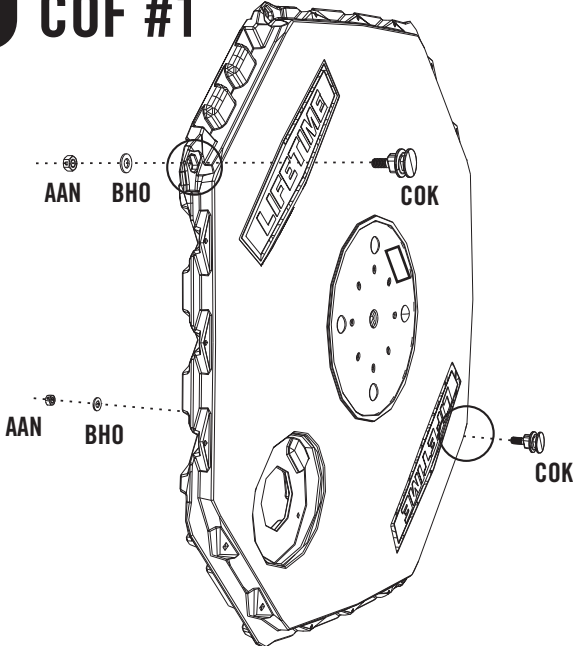

2.8

COF #2

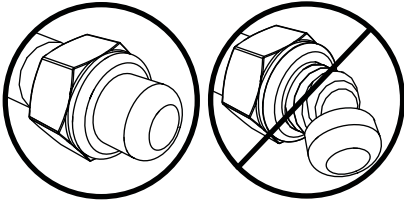
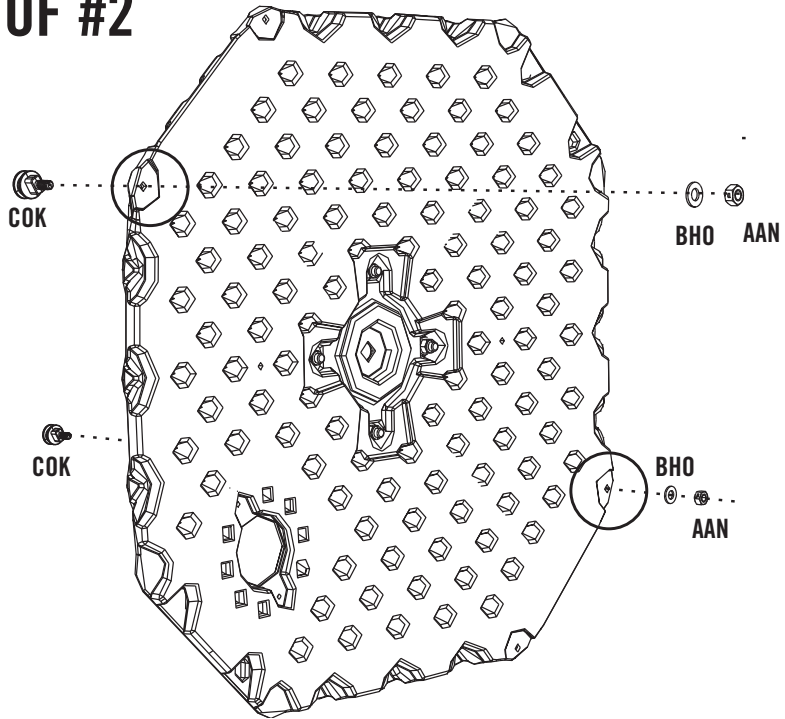

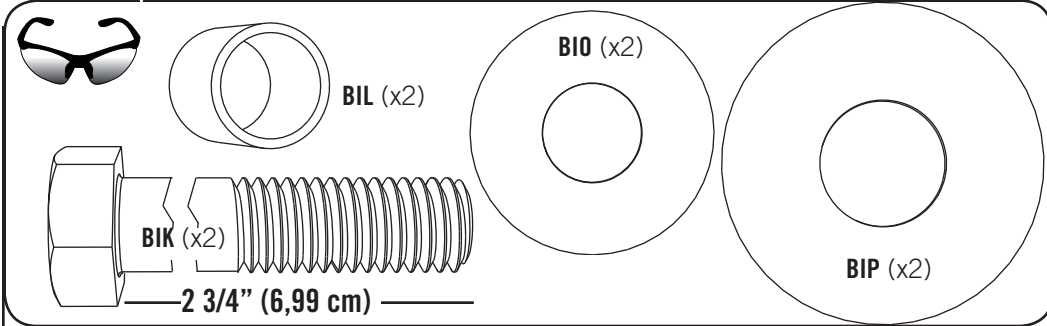
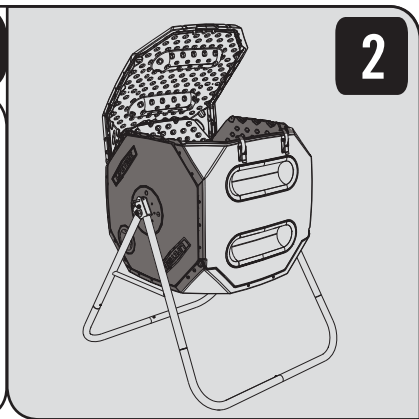

2.9

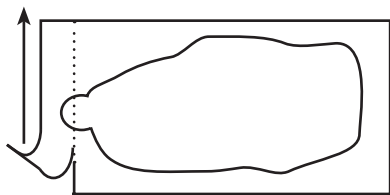

2.10

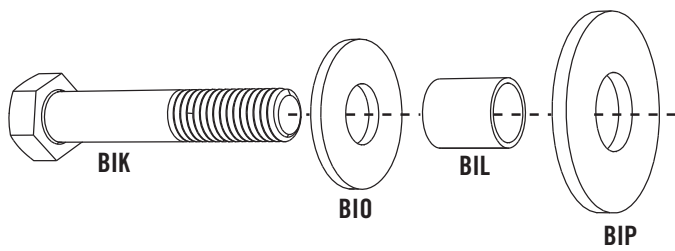

2.11

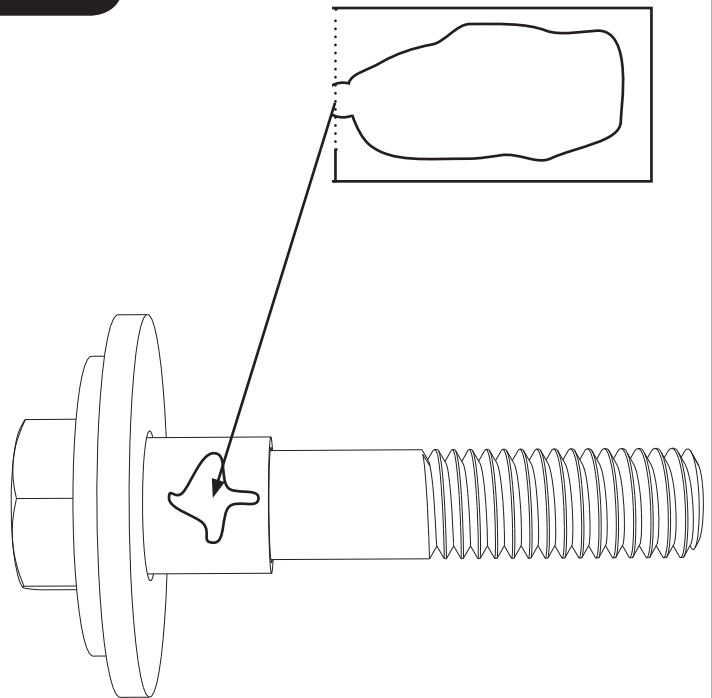

2.9 - 2.10 x2!



2



3/4"

3/4"

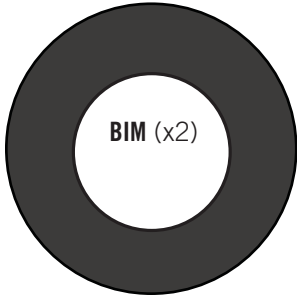

BIM (x2)

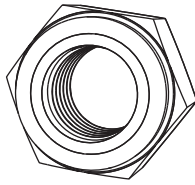

ADM (x2)

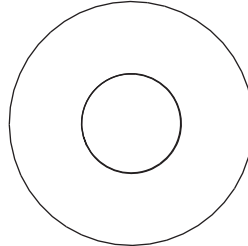

BIO (x2)

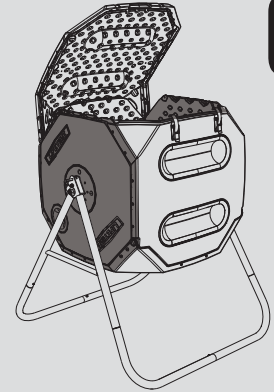

2.12

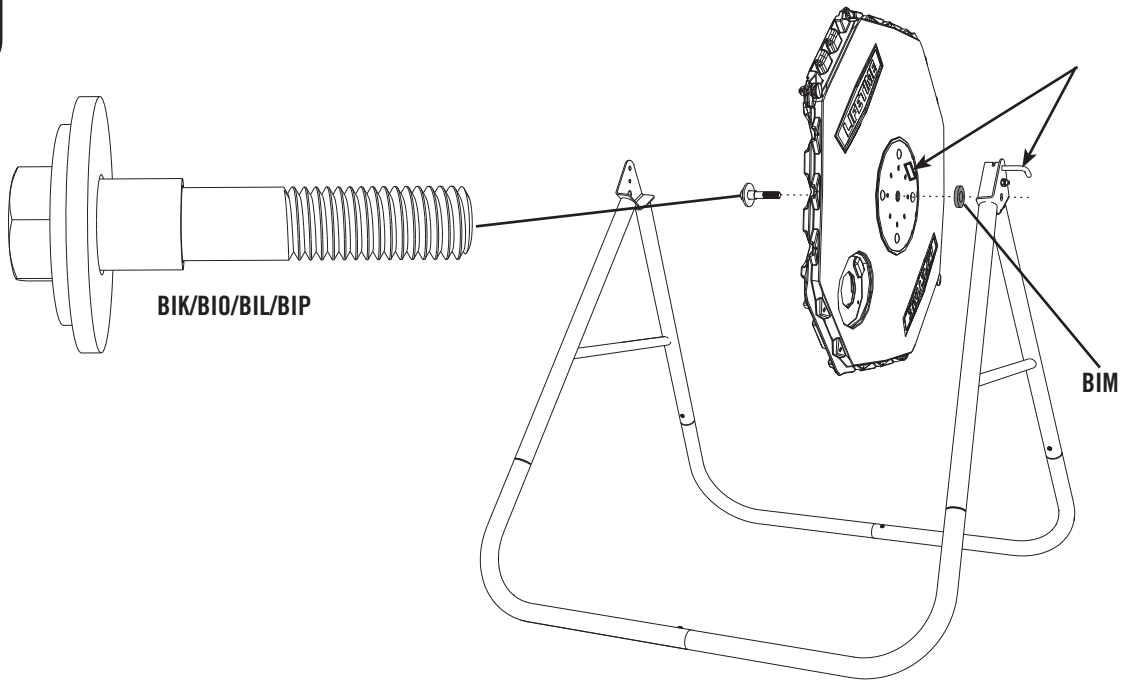

2.13

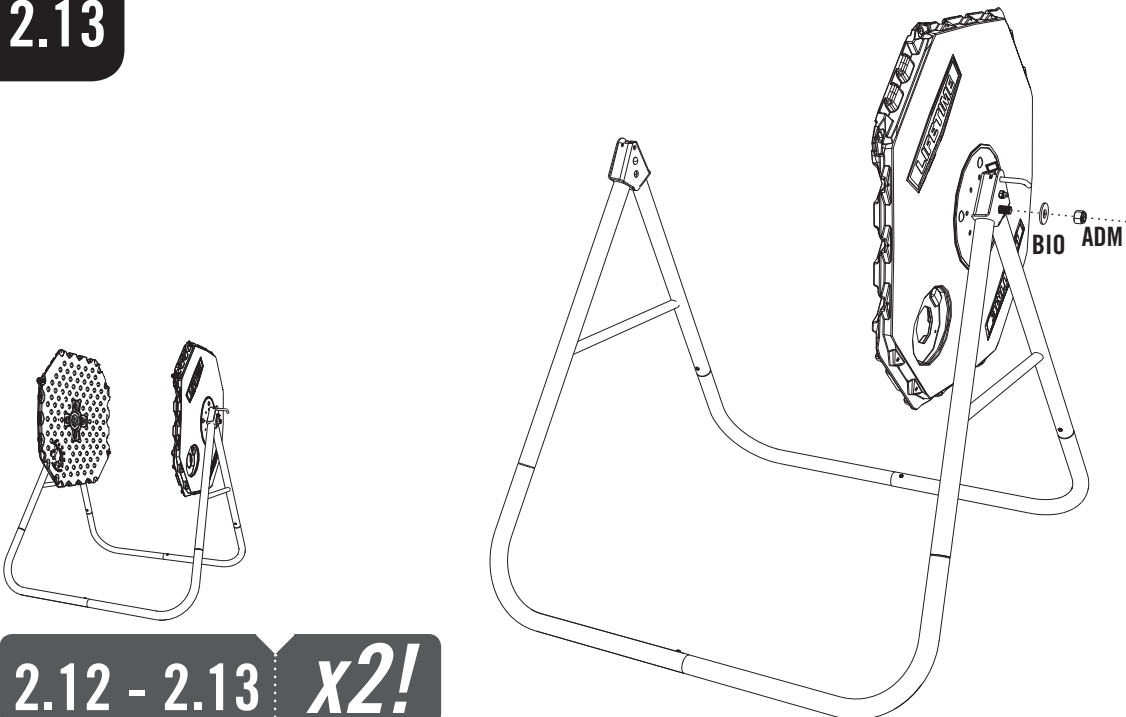

2.12 - 2.13 **x2!**

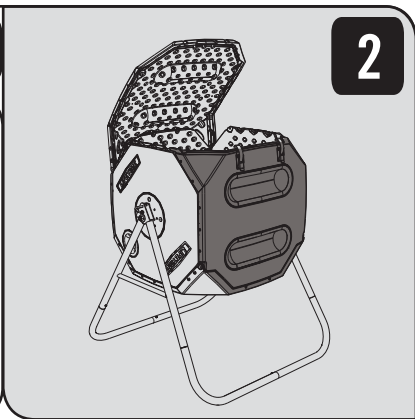
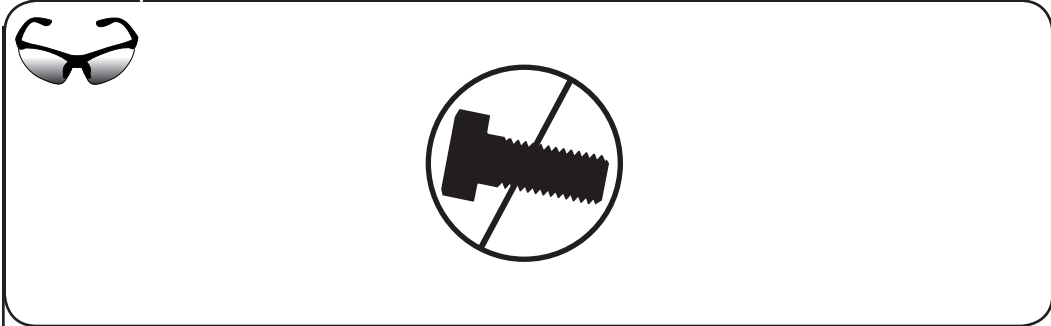

2.14

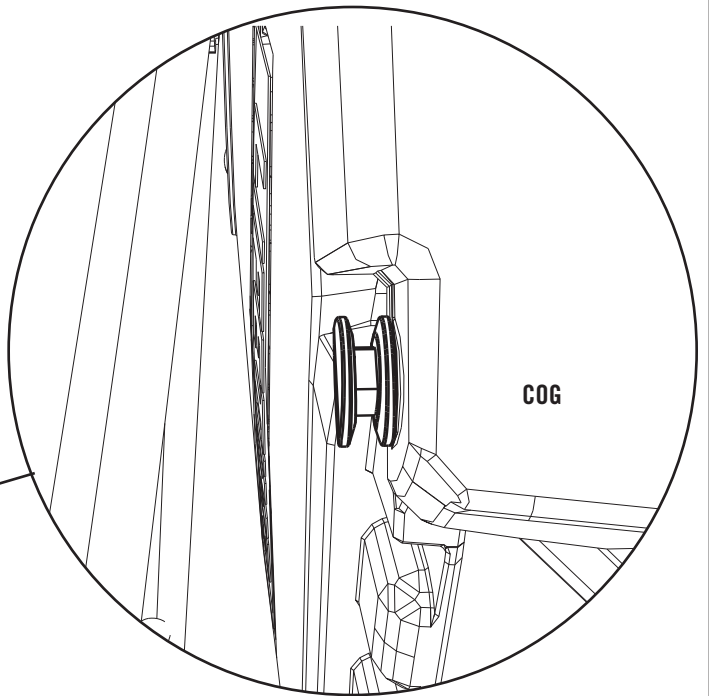
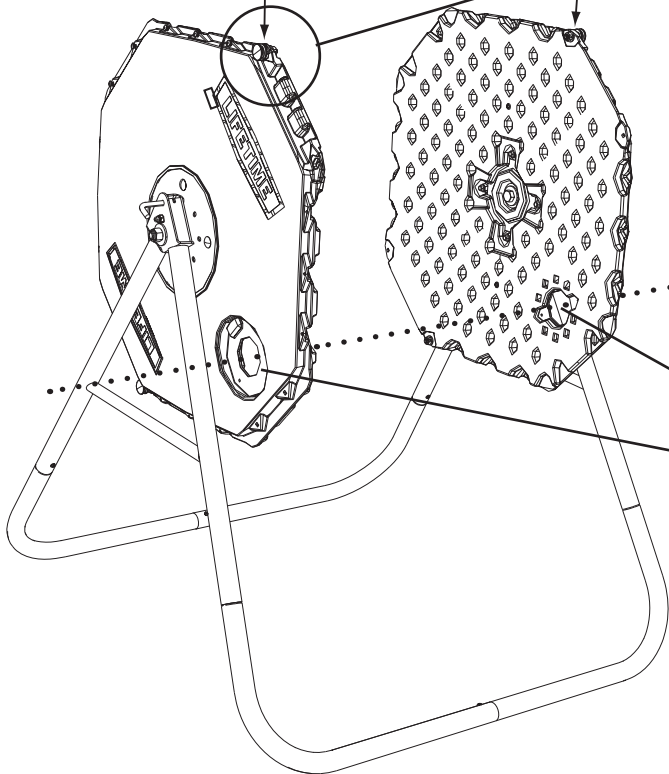
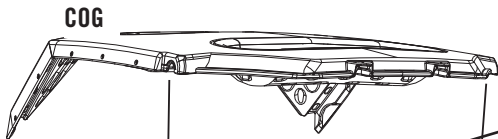
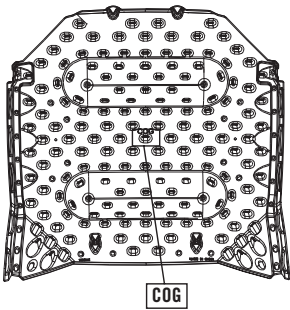

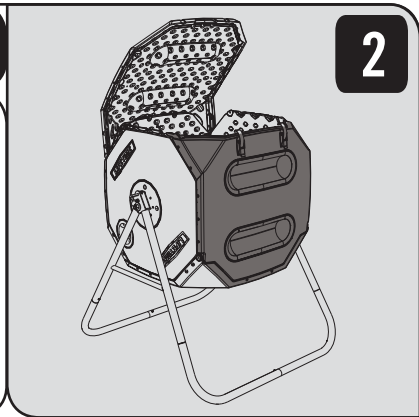
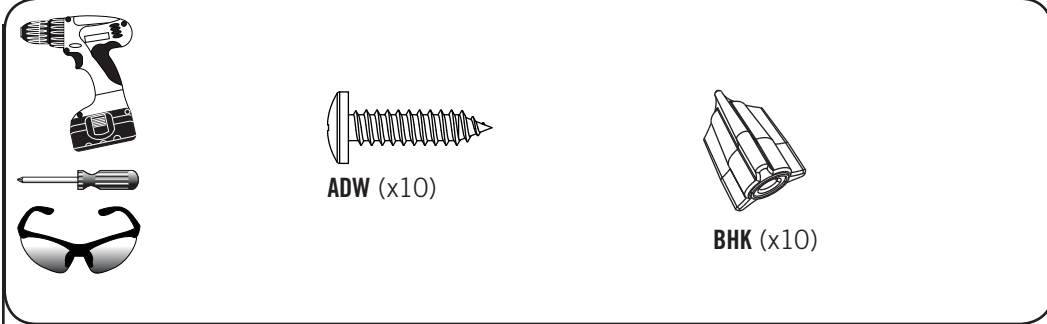

2.15

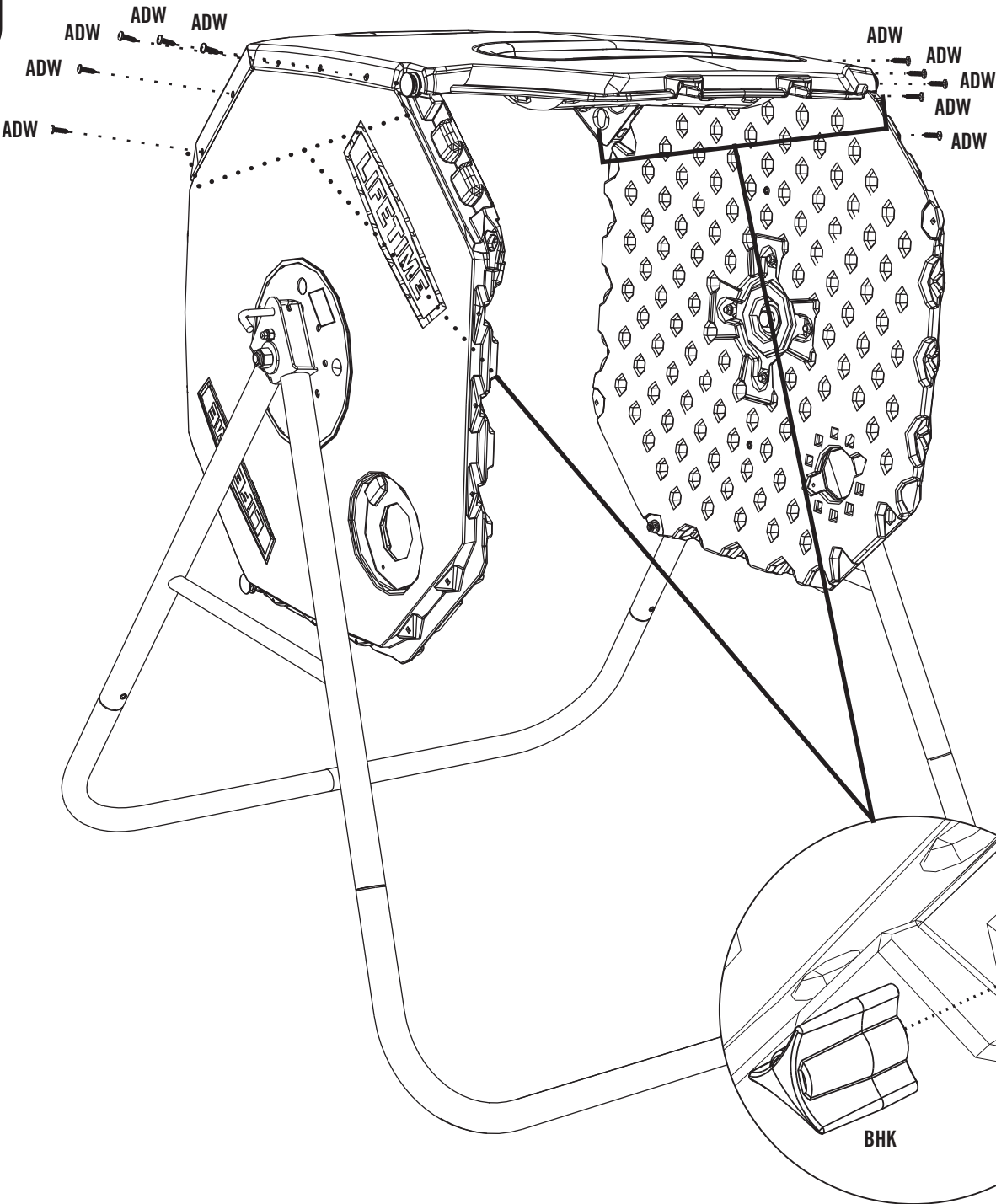



2

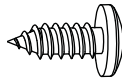
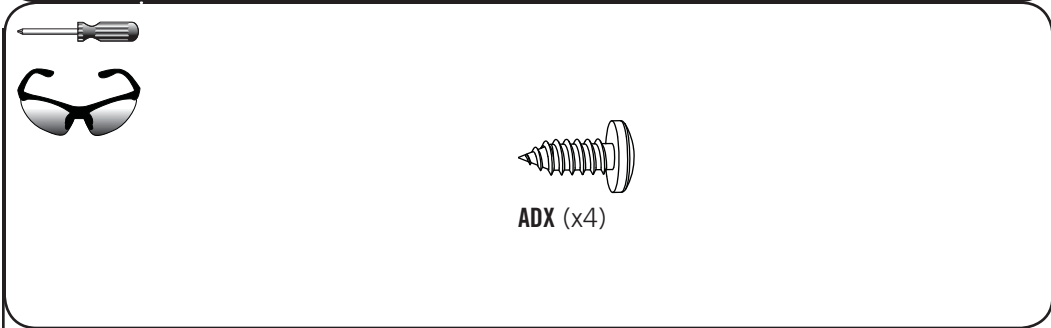

ADX (x4)

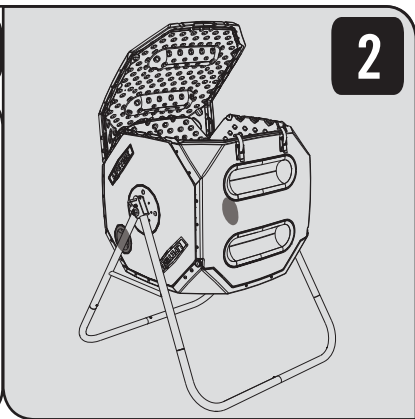

2.16

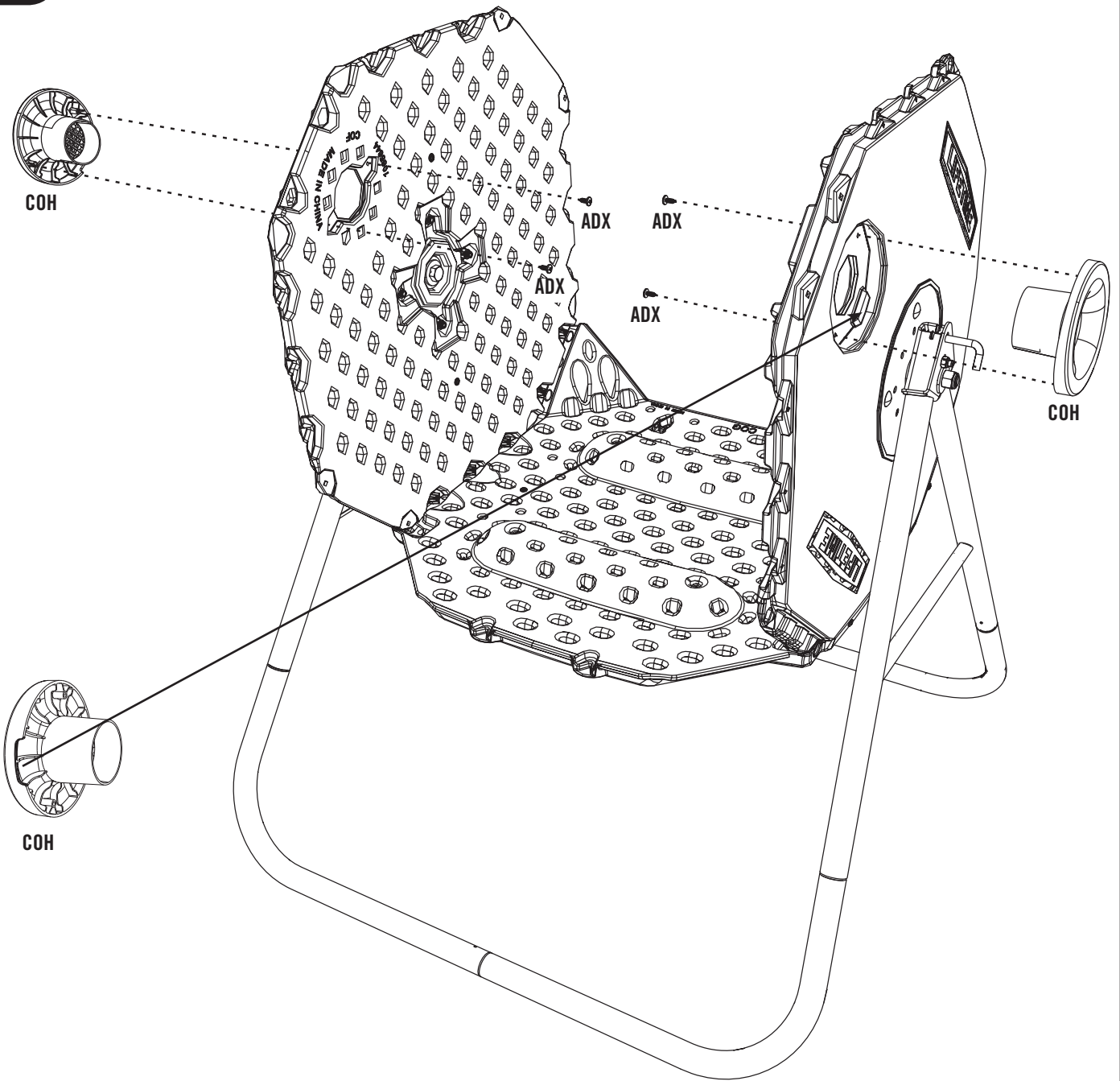

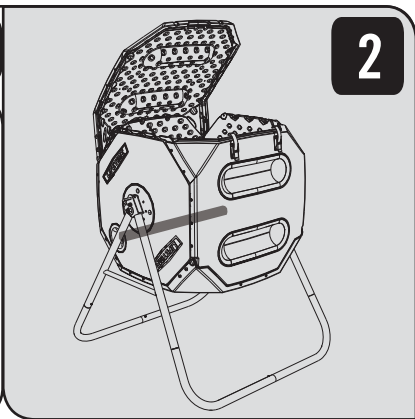
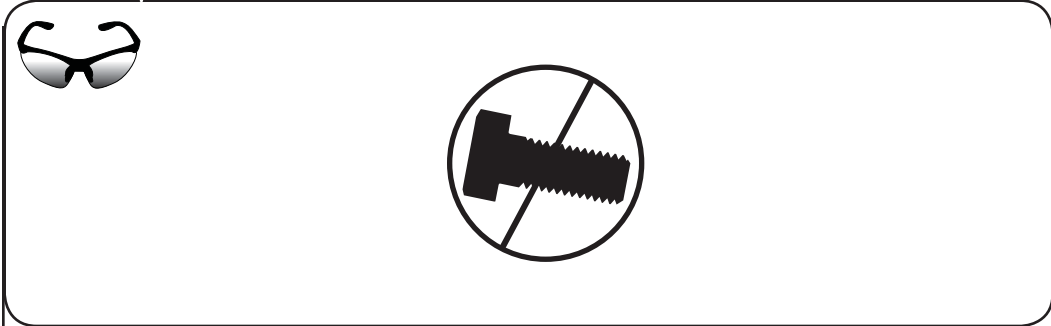

2.17

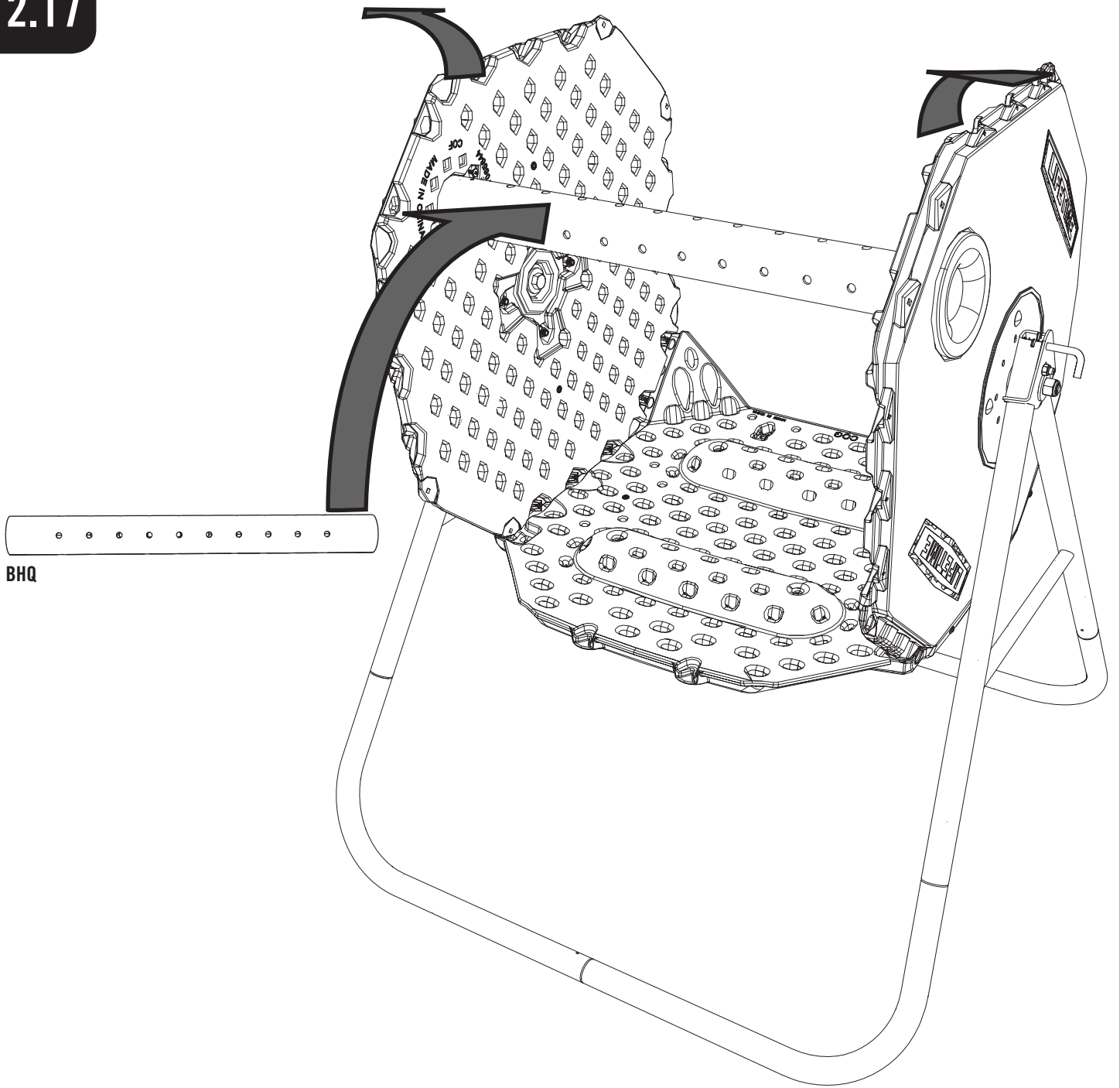

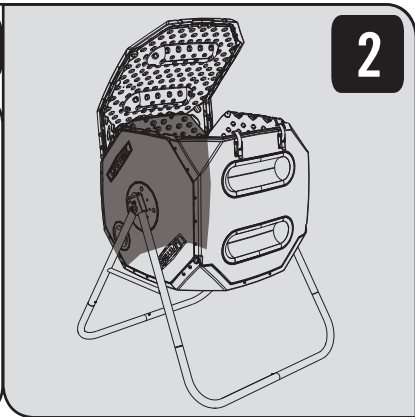
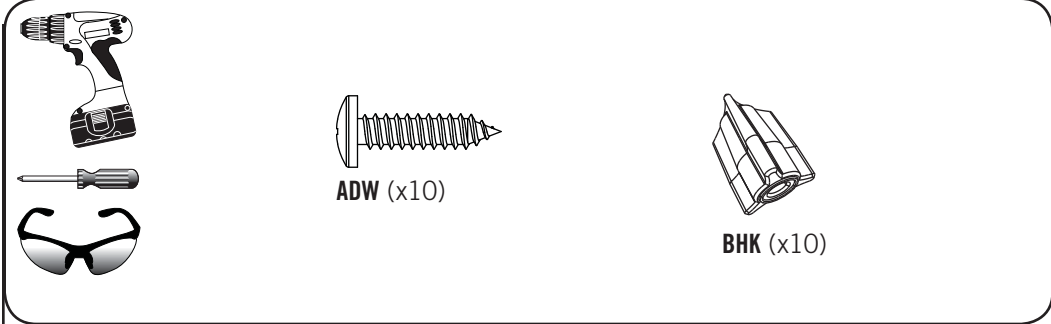

2.18

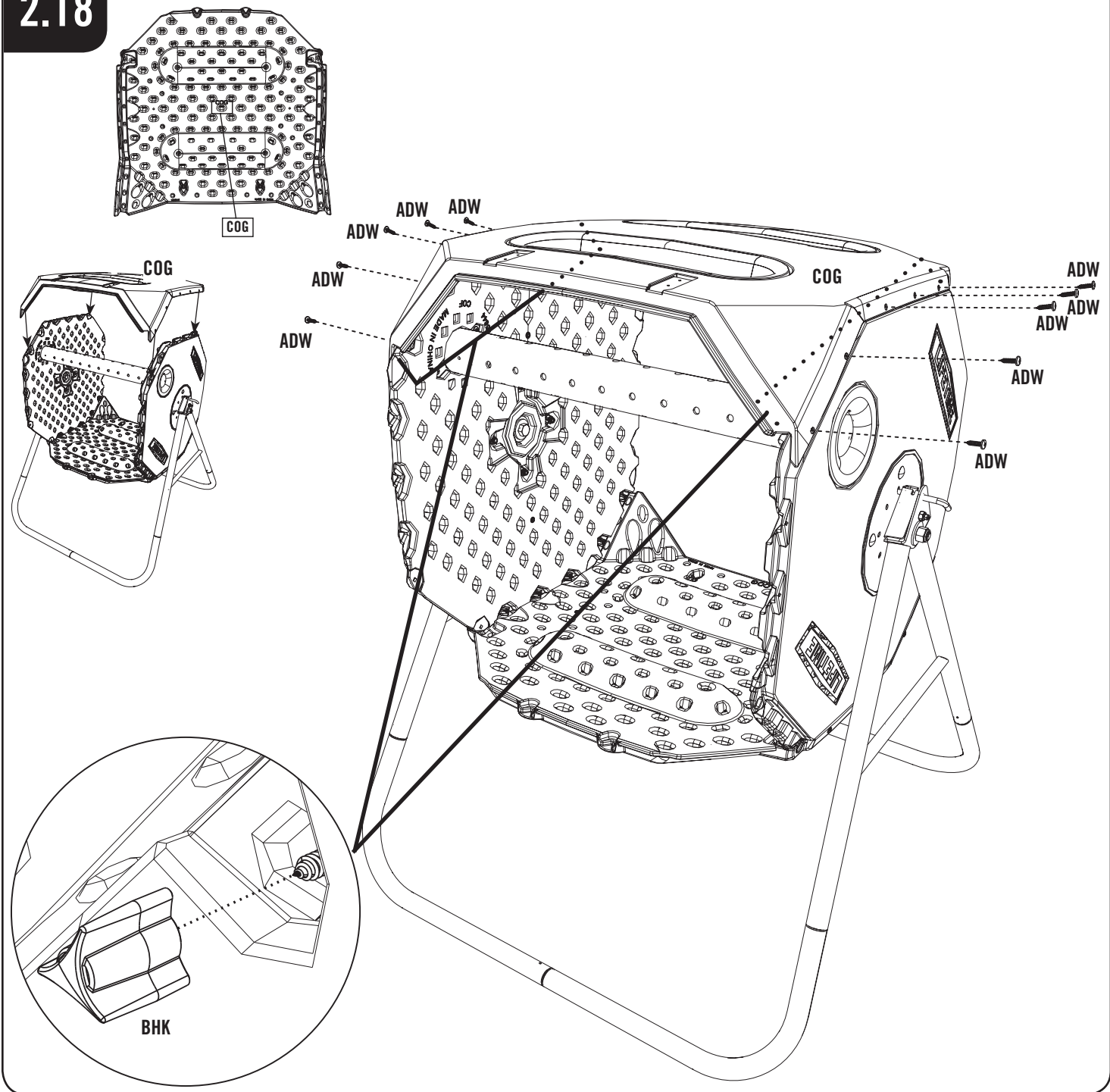



2

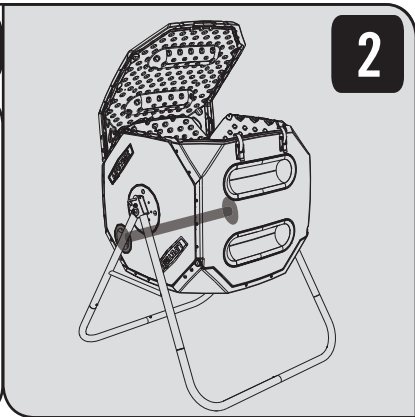
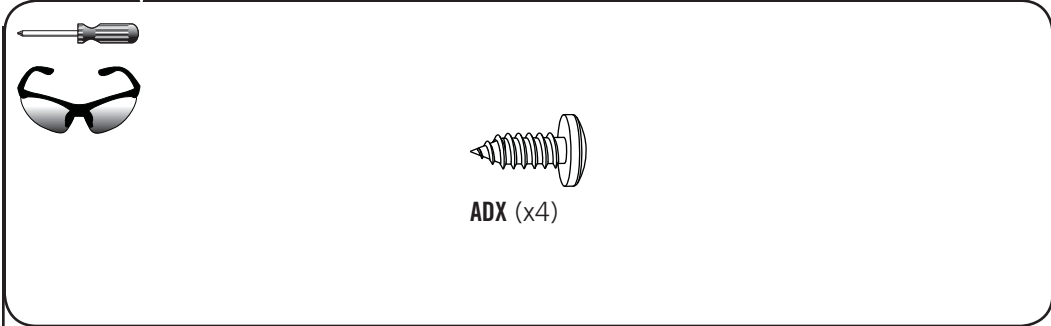

2.19

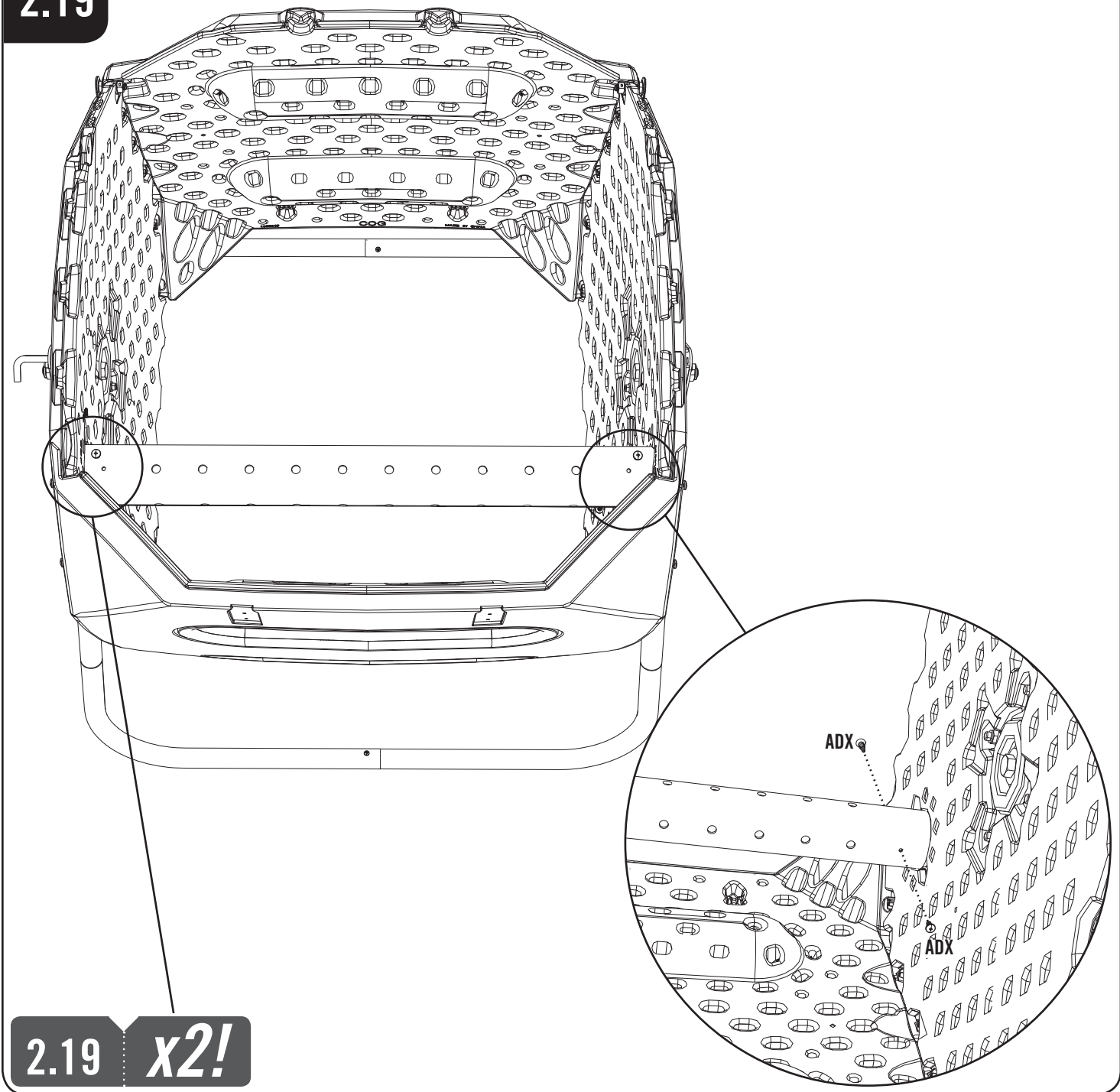

2.19 x2!

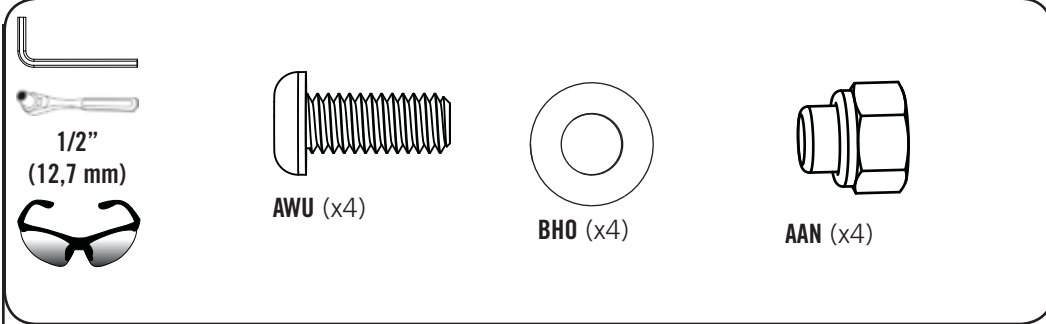
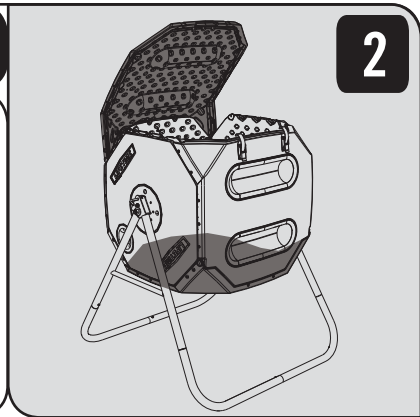

2.20

COE #1

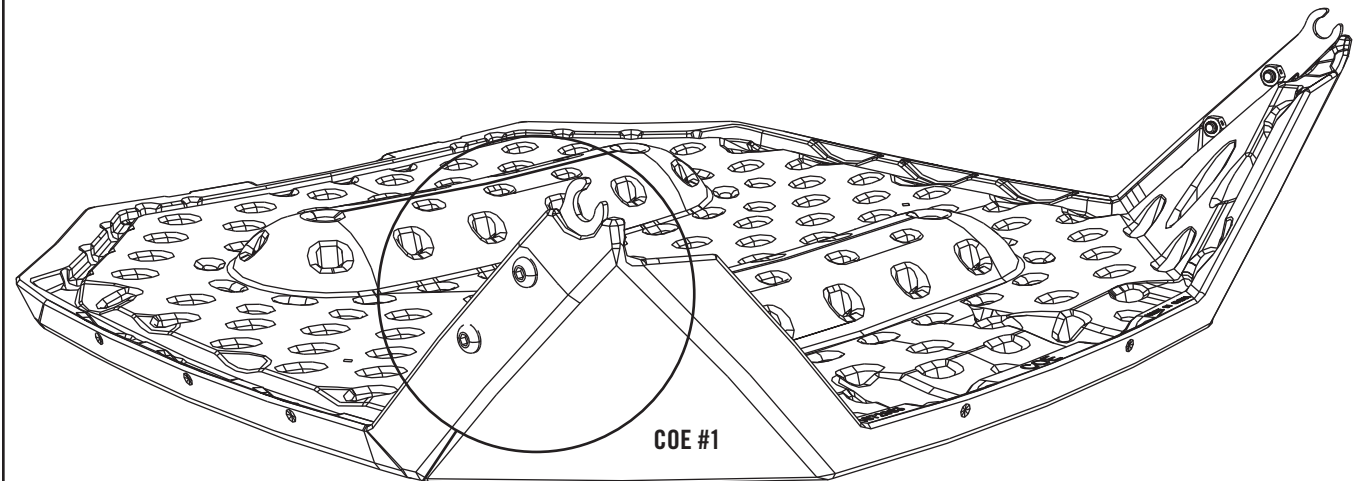
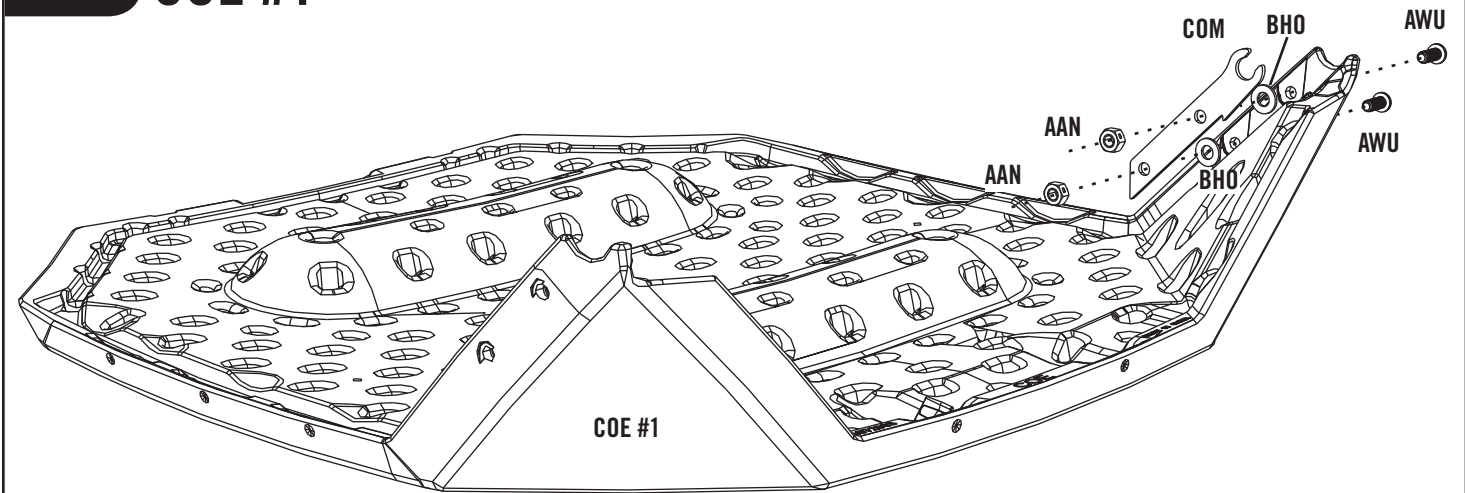

2.20 x2!

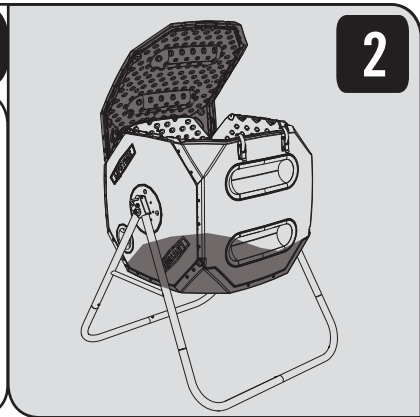

1/2"
(12,7 mm)

AWU (x4)

BHO (x4)

AAN (x4)

2.21

COE #2

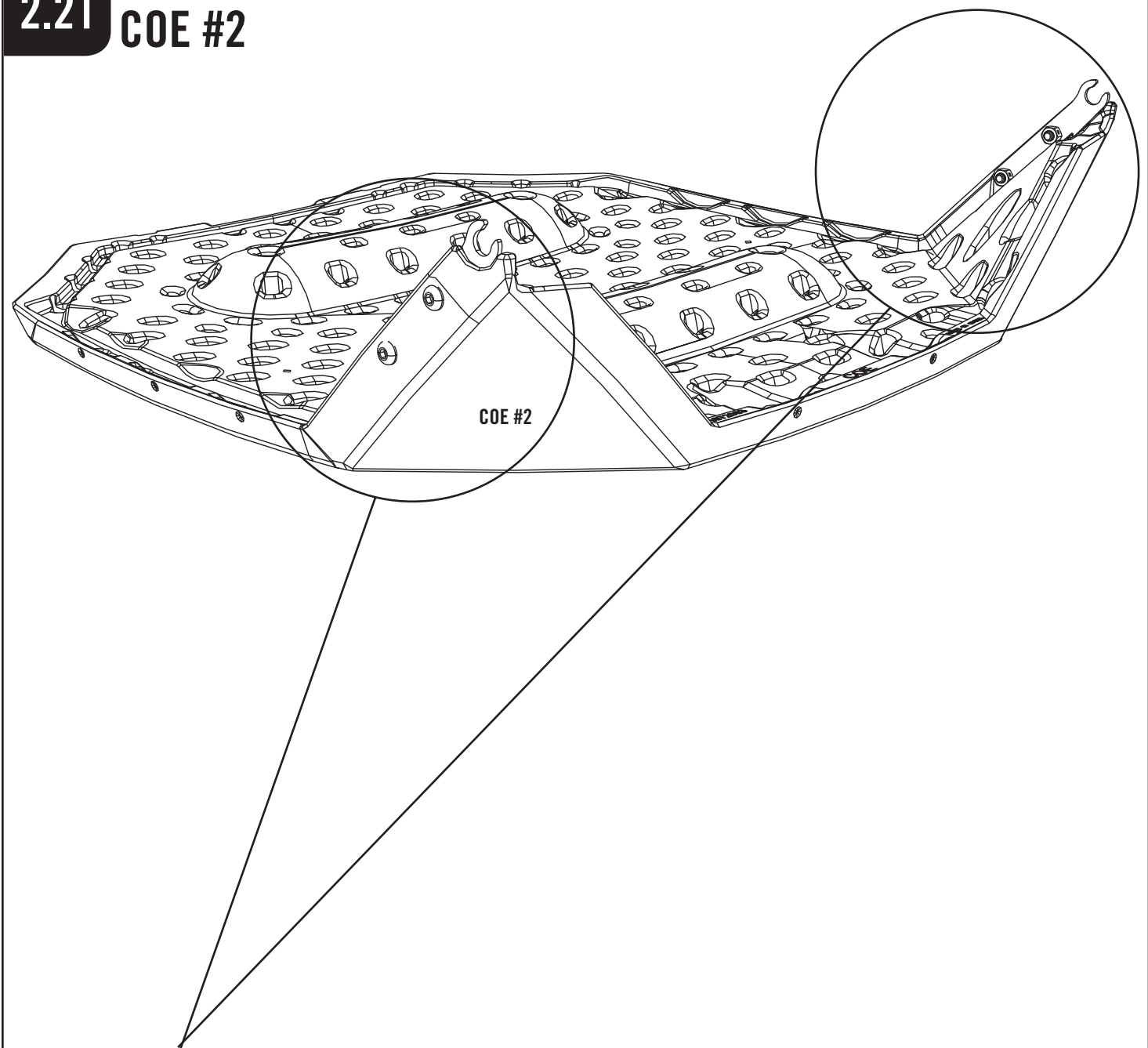

2.20 x2!

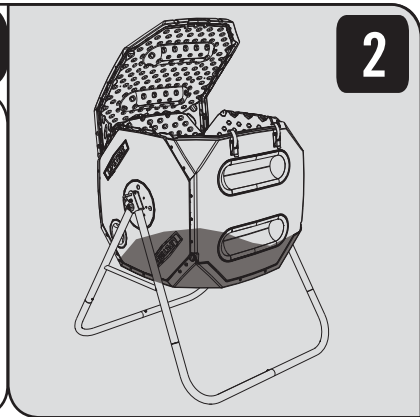
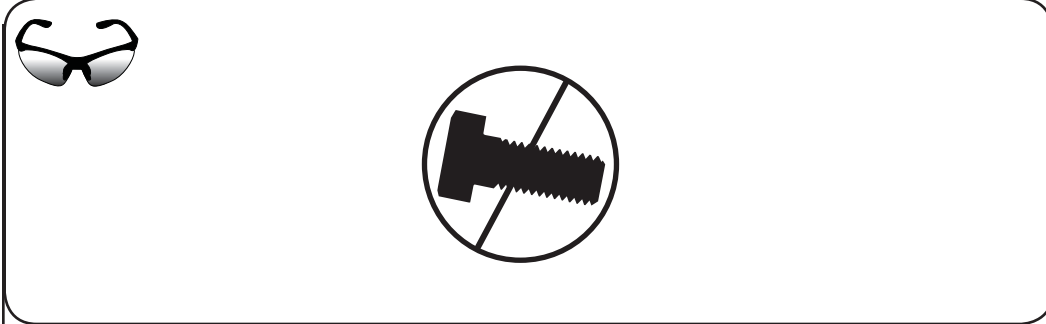

2.22

COE #1

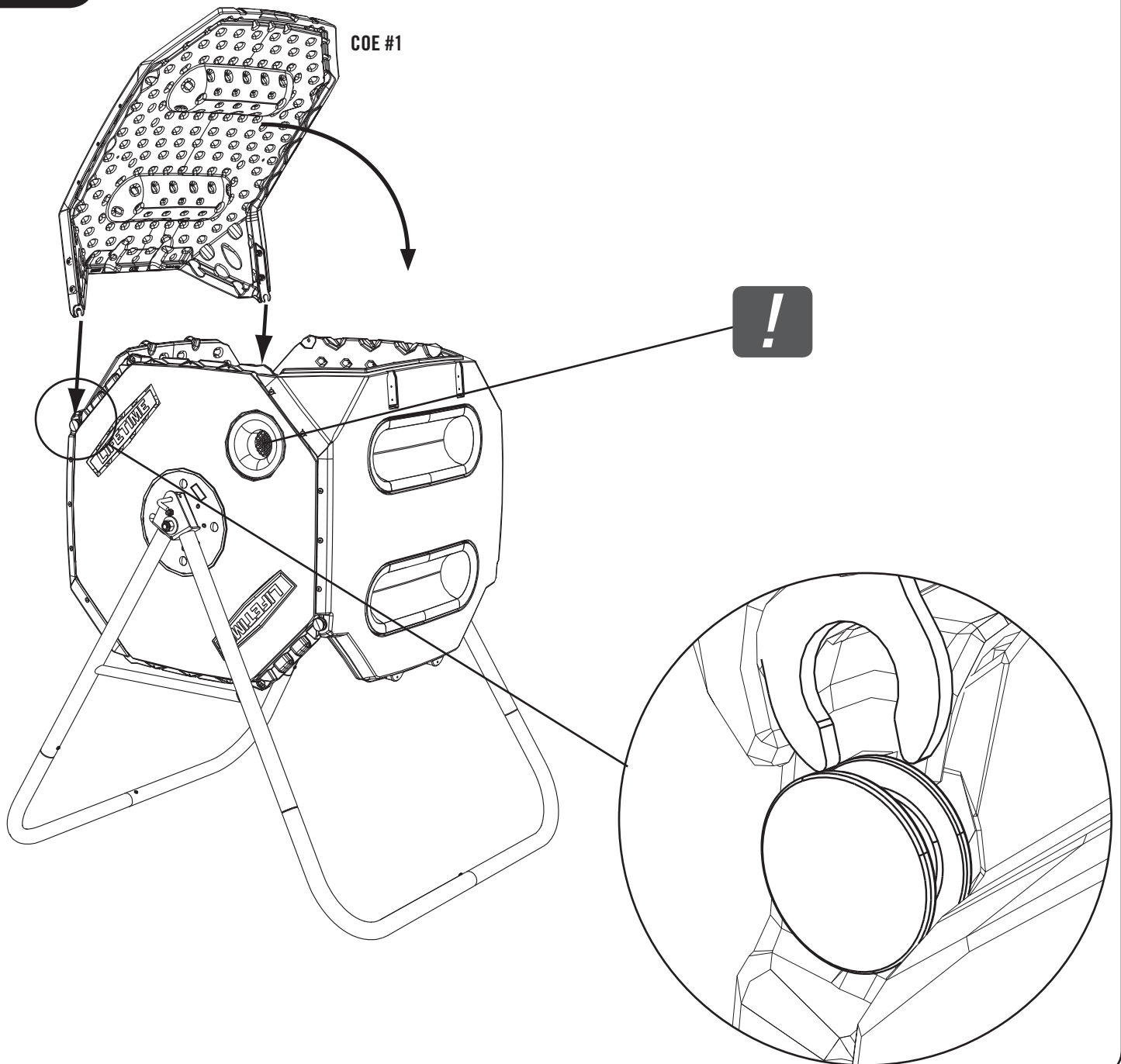

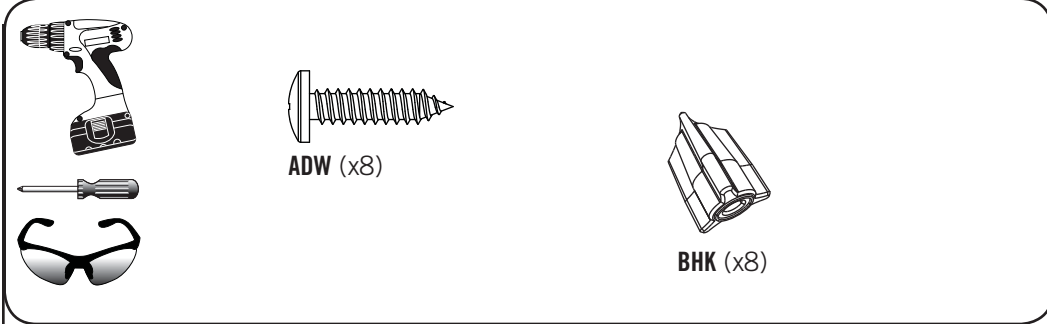
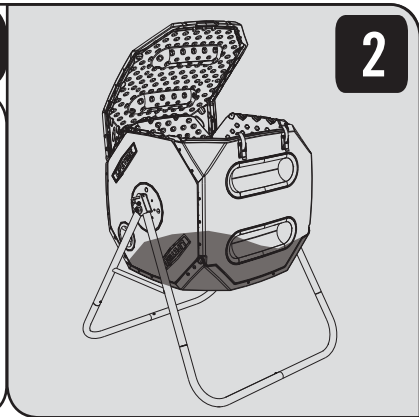

2.23

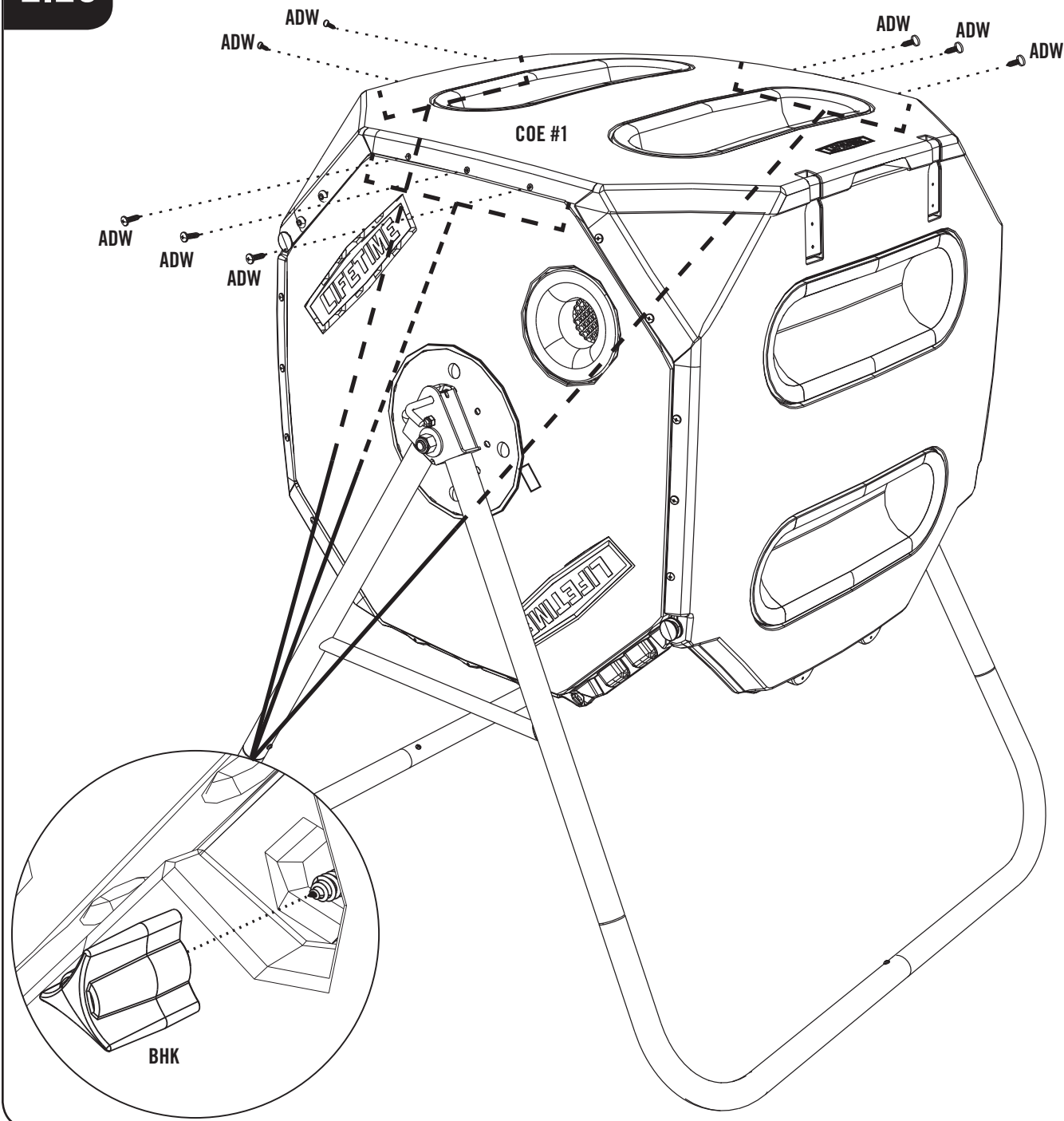

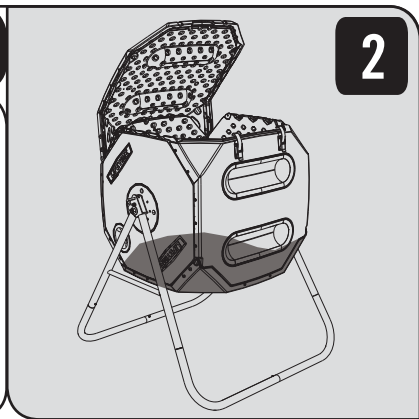
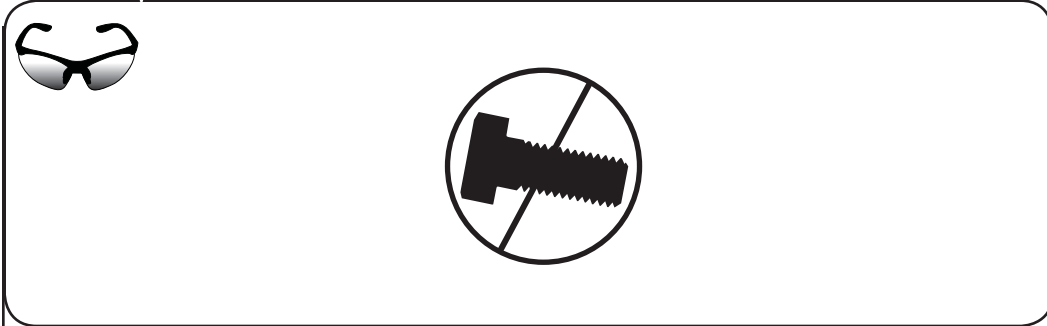

2.24

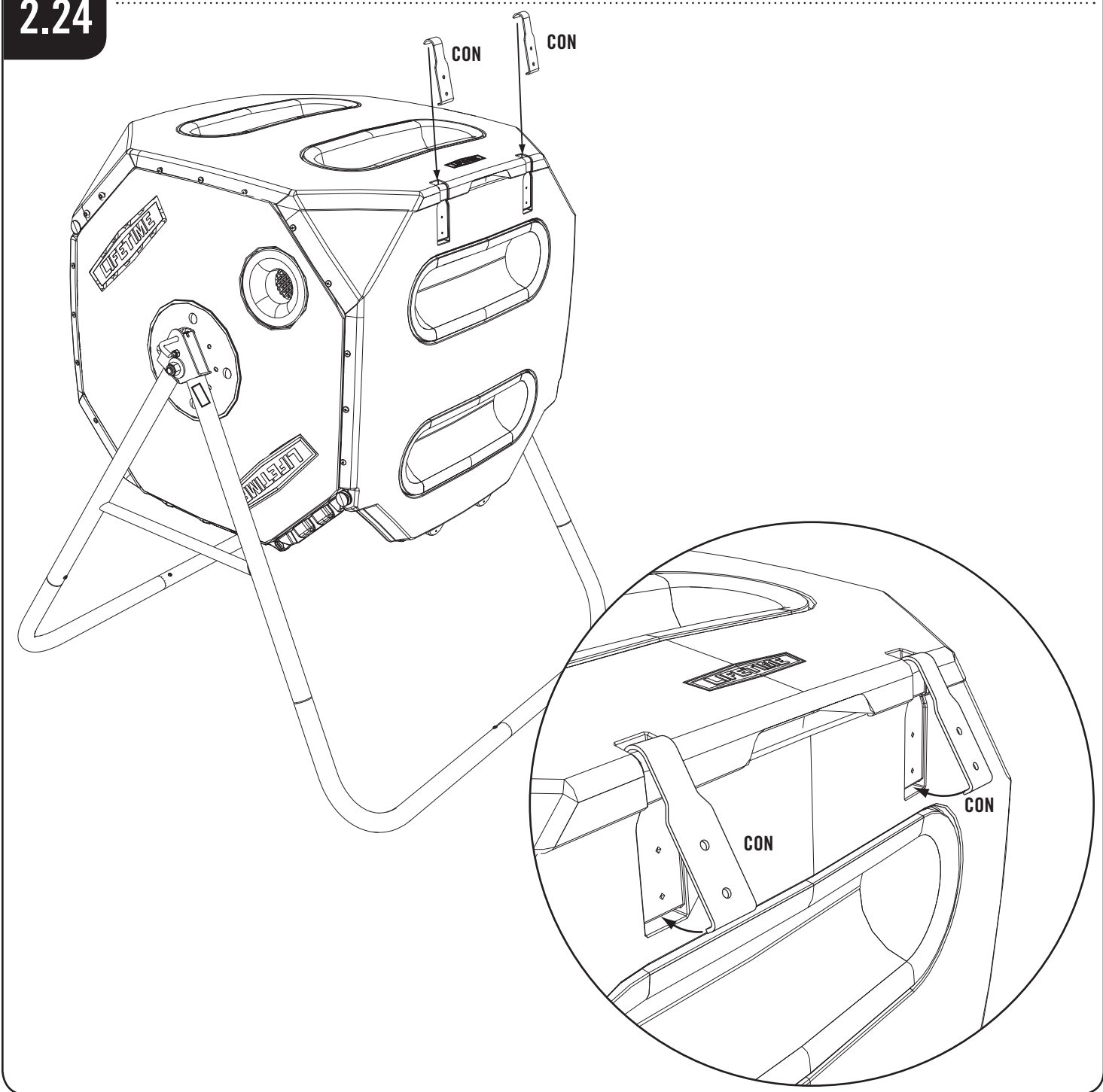

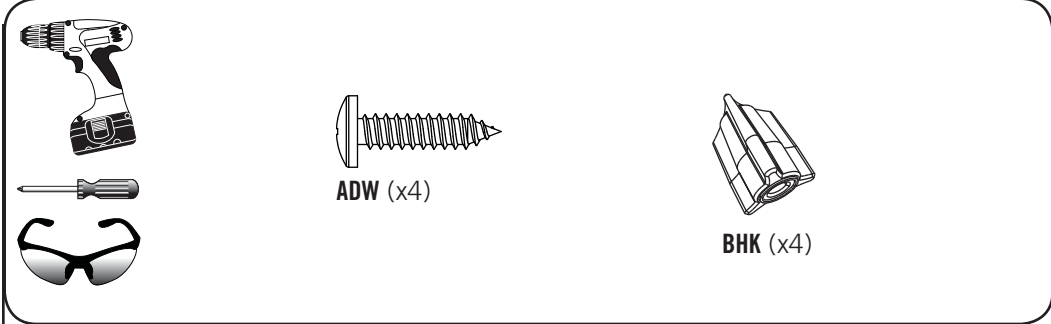
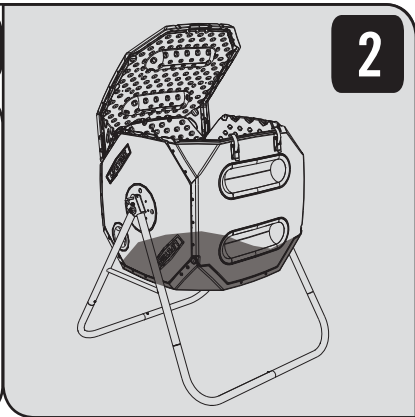

2.25

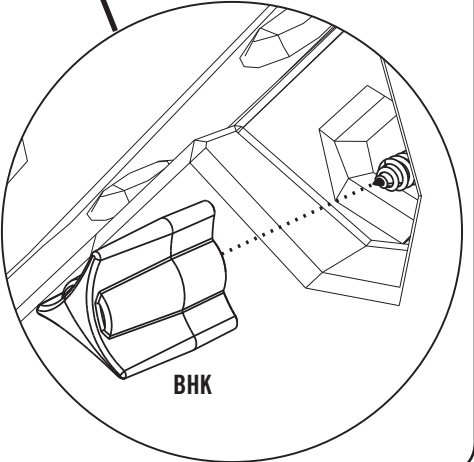
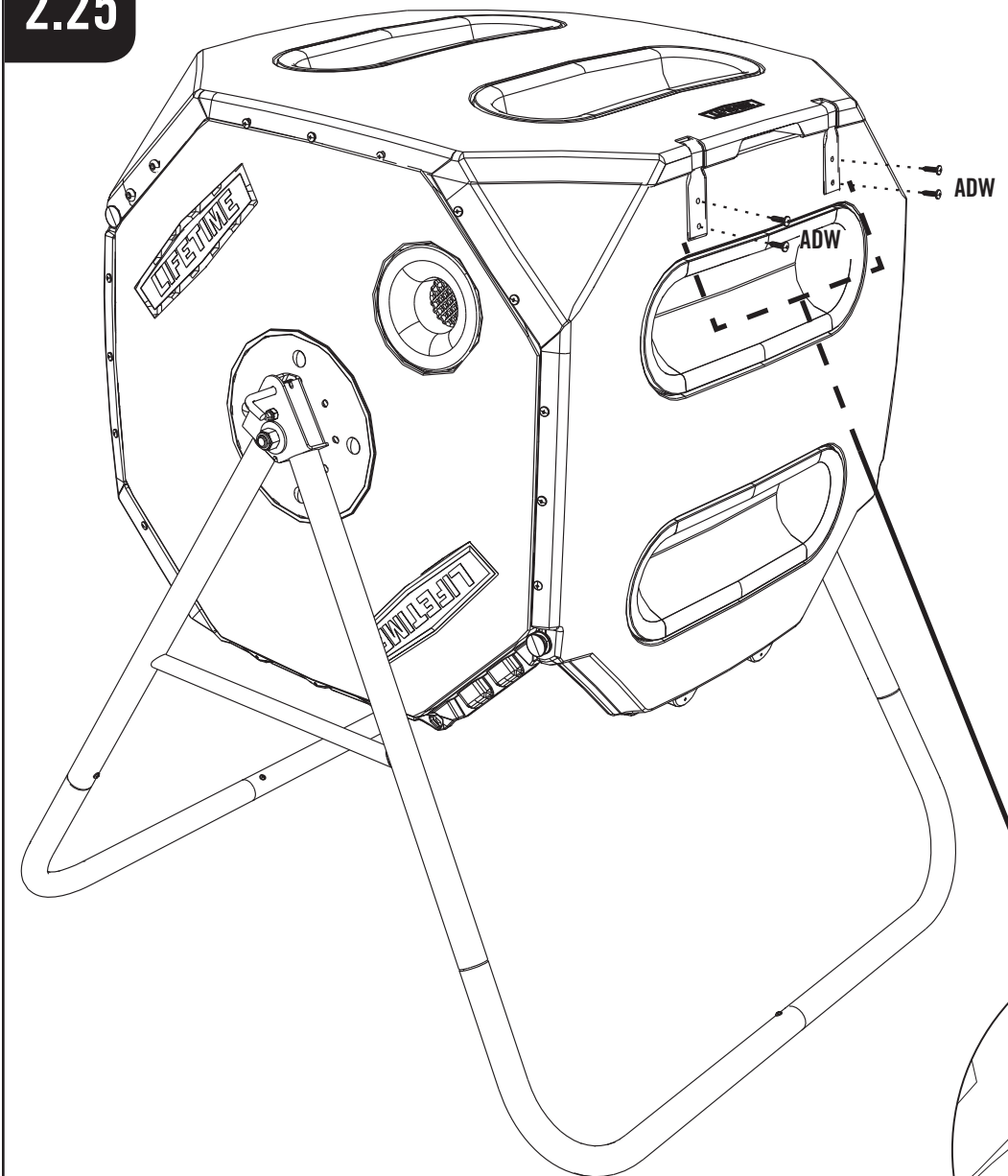

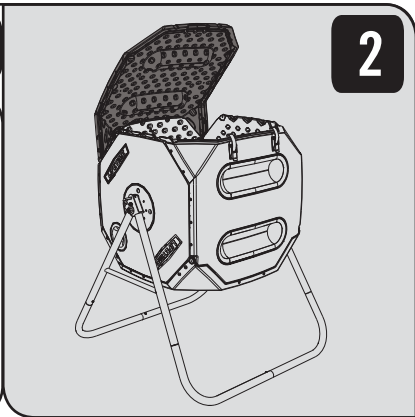
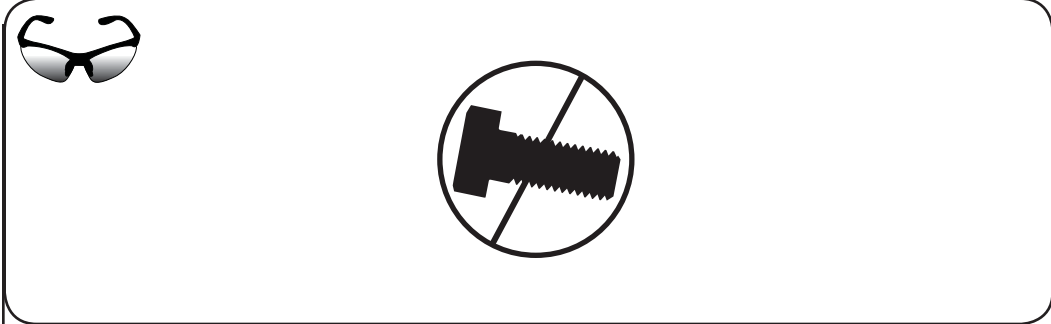

2

2.26

COE #2

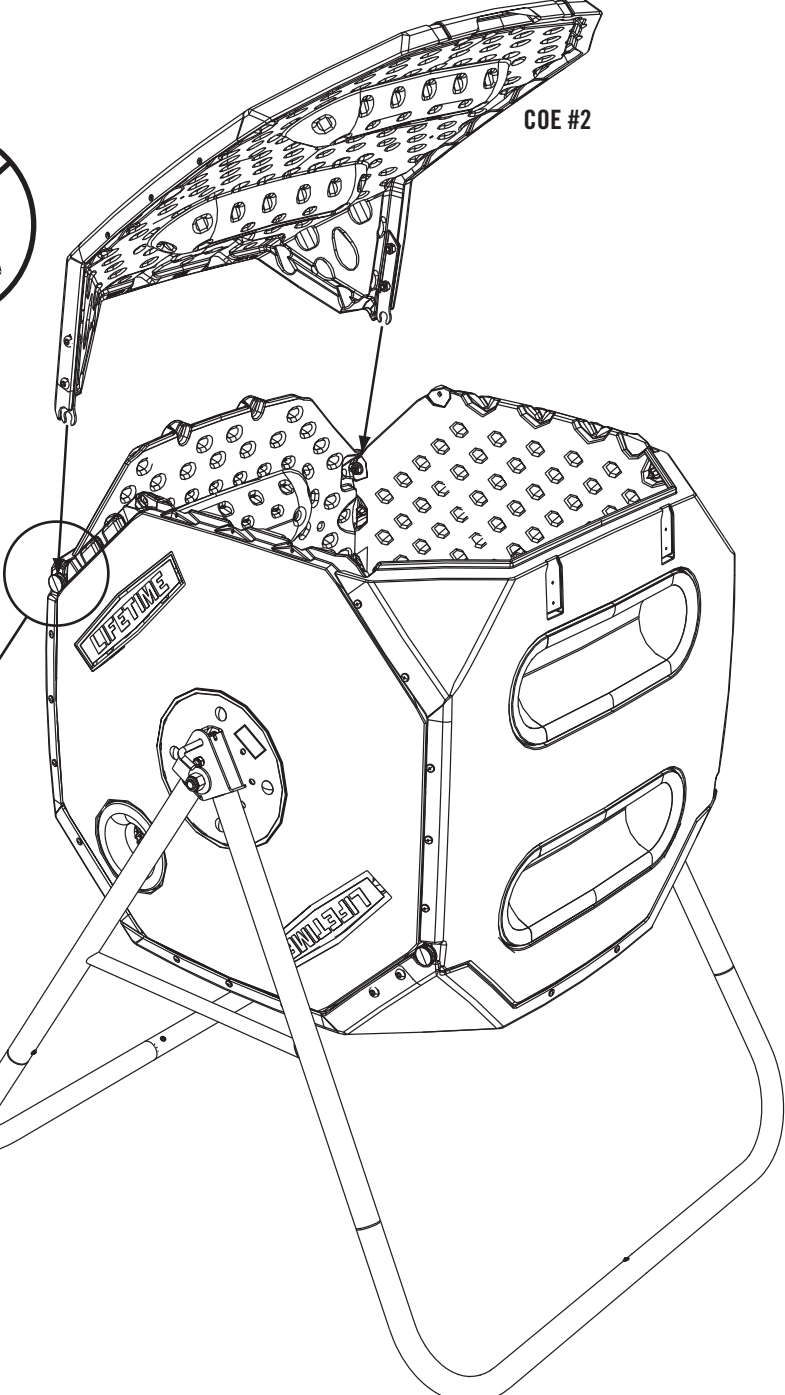
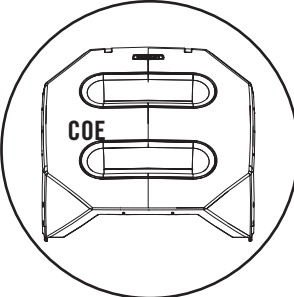

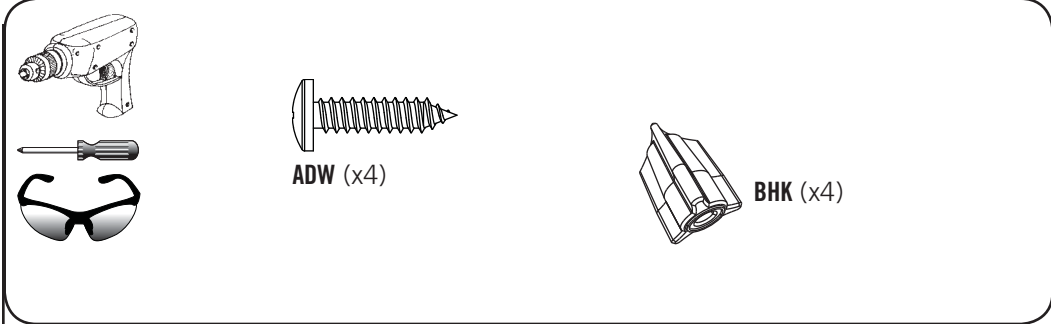
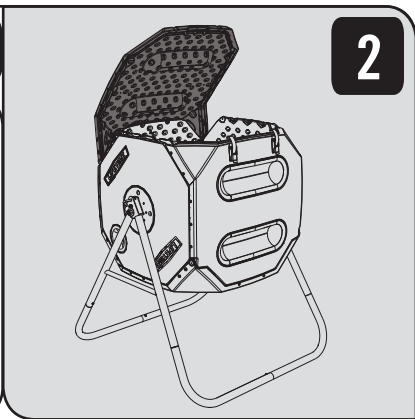

2.27

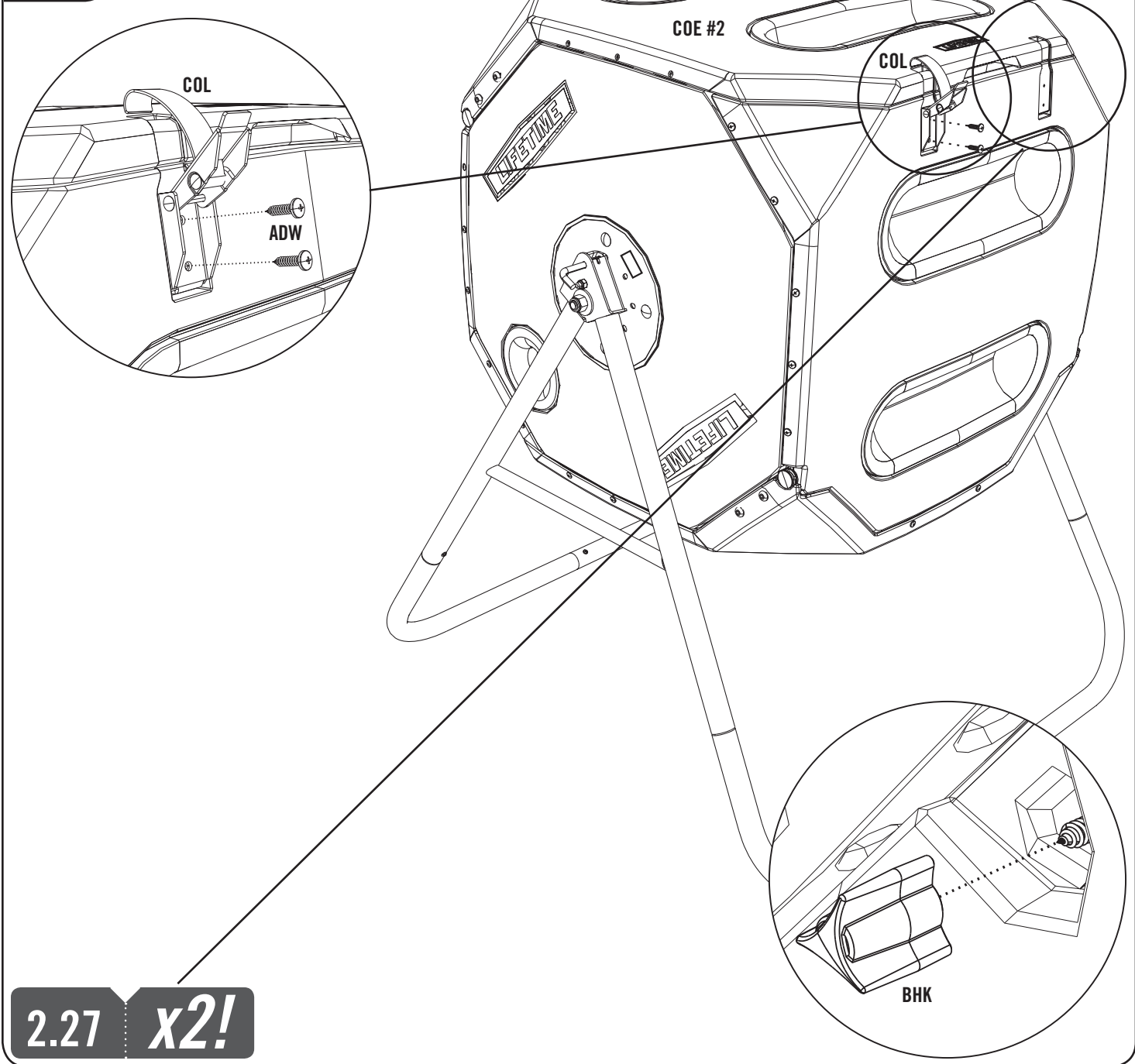

2.27 x2!