

718820514

Owner's Manual & Assembly Guide



INNOVATION UNDER COVER[®]

www.arrowsheds.com

Model No. DSM42

4' x 2'
Nominal Size

! caution
sharp edges *

Gloves must be worn at all times to reduce risk of injury!

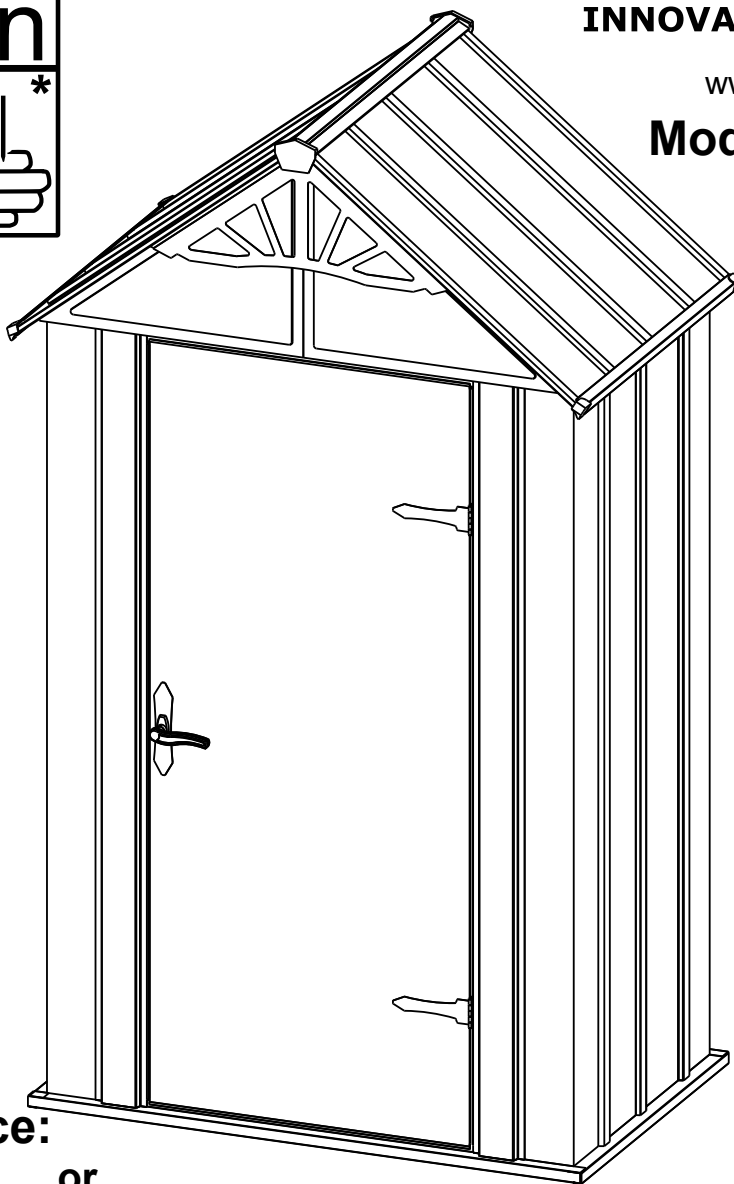

Customer Service:
1-800-851-1085 or
assist@arrowsheds.com

Base Size	52 1/8" x 33 7/8" 132,4 cm x 86,0 cm
------------------	---

BUILDING DIMENSIONS † Size rounded off to the nearest foot

Approx. † Size	Storage Area		Exterior Dimensions (Roof Edge to Roof Edge)			Interior Dimensions (Wall to Wall)			Door Opening	
			Width	Depth	Height	Width	Depth	Height	Width	Height
4' x 2'	11 Sq. Ft.	71 Cu. Ft.	54 1/8"	36 1/8"	92 1/2"	49 1/8"	30 7/8"	90 1/2"	29 1/4"	69"
1,2 m x 0,8 m	1,0 m ²	2,0 m ³	137,5 cm	91,8 cm	235,0 cm	124,8 cm	78,4 cm	229,9 cm	74,3 cm	175,3 cm

* See Inside for Detailed Safety Information.

SAFETY PRECAUTIONS...

Safety precautions MUST be followed at all times throughout the construction of your building!

sharp edges

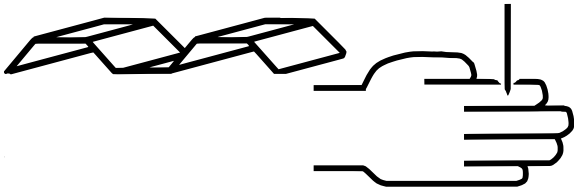

Care must be taken when handling various pieces of your building since many contain sharp edges. Please wear work gloves, eye protection and long sleeves when assembling or performing any maintenance on your building.

always practice proper tool safety

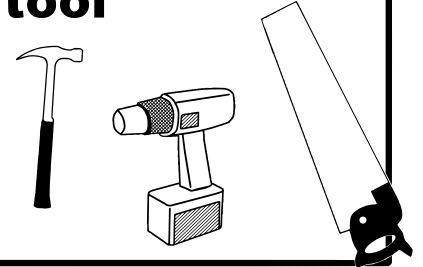

Practice caution with the tools being used in the assembly of this building. Be especially familiar with the operation of all power tools.

no children or pets at worksite



Keep children and pets away from the worksite during construction and until the building is completely assembled. This will help avoid distractions and any accidents which may occur.

don't focus weight on roof

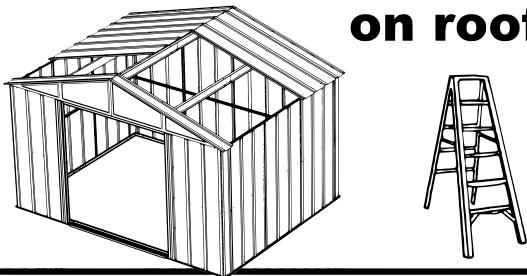

NEVER concentrate your weight on the roof of the building. When using a step ladder make sure that it is fully open and on even ground before climbing on it.

beware of wind



Do NOT attempt to assemble your building on a windy day. The large panels can catch the wind like a "sail", causing them to be whipped around making construction difficult and unsafe.

Do NOT attempt to assemble your building before double checking that you have all the parts indicated on the parts list (page 8) as well as all hardware (page 7). Any building left partially assembled may be seriously damaged by even light winds.

IMPORTANT NOTE ON ANCHORING

- Your building MUST be anchored to prevent wind damage. An anchoring kit is not supplied with your building and you have many options when it comes to anchoring. See anchoring page for more info.
- You must also have a temporary anchoring system in place in case you need to take a break from assembly. See page 4 for more info.

ASSEMBLY TIPS & TOOLS

Watch the Weather Closely: Be sure the day you choose to install your building is dry and calm. Do **NOT** attempt to assemble your building on a windy day. Be careful on wet or muddy ground.

Use Teamwork: Two or more people are required to assemble your building. One person can hold the parts or panels in place while the other person fastens them together and handles the tools. This makes the process of assembling your building faster and safer.

Tools and Materials: Here is a list of some basic tools and materials you will need to assemble your building. Decide which method of anchoring and the type of base you will use to make a complete list of the materials you will need.

WHAT YOU NEED

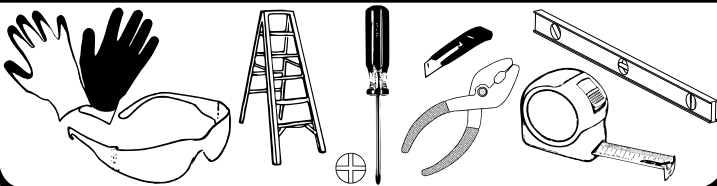

- Work Gloves
- Safety Glasses
- Step Ladder
- No. 2 Phillips Screwdriver (Magnetic Tip Preferred)
- Utility Knife or Scissors
- Pliers
- Carpenter's Level
- Tape Measure

RECOMMENDED TIME SAVERS

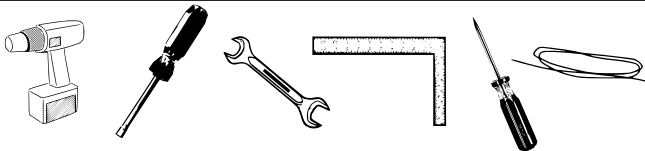

- Power Drill (Cordless, Variable Speed)
- Nut Driver or Wrench
- Square
- String (for squaring the frame)
- Awl (to align holes)

BASE PREPARATION TOOLS

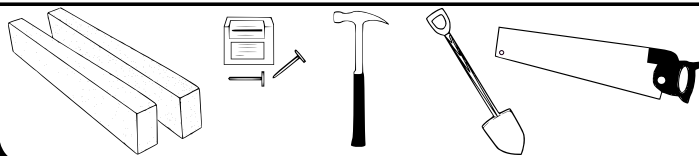

- Lumber and/or Concrete
- Hammer and Nails
- Spade or Shovel
- Hand Saw or Power Saw

How to Select and Prepare Your Building Site: Before you start to assemble your building, you will want to decide on a good location. The best location is a level area with good drainage.

- Allow enough working space so it is not difficult to move parts into position for assembly. Be sure there will be enough space at the entrance for the doors to completely open. Also, there needs to be enough space outside the building to be able to fasten the panel screws from the outside.
- Before assembling any parts, your base should be constructed and an anchoring system should be ready to use.

FREQUENTLY ASKED QUESTIONS

Q. How long will it take to assemble the building?

A. Assembly time depends on a variety of factors, including roof design, tools available, DIY skill and the pace at which you work. Guidelines for each shed assembly are approximate AFTER completion of the base, and assume two or more people working on the assembly. Generally, you should plan on at least one day working with someone who can assist you; again, after constructing the base. Refer to the clock icons on each product page on the website for specific time estimates.

Q. How do I decide where to put my shed?

A. The key to a successful assembly is to make sure the shed will be square and level when built. The shed can be assembled directly onto level ground (grass or dirt). If you have location options, choose one that is already flat, with good drainage to control moisture. If you don't have a flat, well-drained area, you need to prepare the space. Level the area using cinder blocks, concrete, crushed gravel or other sturdy materials. Once level with good drainage, construct your base. Using a carpenter's level, make sure your base is level and free of bumps or ridges to provide good support for your building.

Q. What if I can't finish my building in one session?

A. If weather conditions change so that it becomes windy or rainy, it is recommended that you stop assembly until conditions improve. This is for your safety and for protection of the shed panels. However, do not leave your unfinished construction without first temporarily anchoring the corners of the shed to your base and placing weights, such as patio blocks or sandbags, on the floor frame. Failure to anchor the building if you leave it while partially assembled could result in irreparable damage or personal injury if the building collapses.

Note: Most instruction manuals provide a warning note at the beginning of the installation step for corner panels, stating that the remainder of the building assembly requires multiple hours and more than one person. Do not continue beyond this point if you do not have enough time or help to complete the assembly that day. A partially assembled building can be severely damaged by even light winds.

Q. Do I need to anchor my building?

A. Yes! Fully assembled buildings should be anchored using a permanent anchoring system. If you need to leave your building before it is completely assembled, you will need to temporarily anchor the corners of the shed to your base, and place weights, such as patio blocks or sandbags, on top of the floor frame.

Q. How do I temporarily anchor my building before it's fully assembled?

A. An incomplete building must be anchored before breaking for any period of time to prevent possible damage.

- If the building is on a wood base, secure the frame with wood screws in the corners
- If the building is on a concrete base, temporarily anchor the frame in the corners
- Use patio blocks or sandbags on top of the floor frame as weights
- Secure the floor frame to the ground with ground augers or rope the frame in the corners to the ground

Q. How do I control condensation and prevent water from leaking in?

A. To minimize condensation, install a continuous, unbroken plastic vapor barrier with a thickness of 6 mil. between exposed ground surface and the building's base. Make sure that all weather stripping and washers are used throughout the assembly process. Make sure that the weather-stripping tape adheres to the panels when installing it along the main ridge beam. Do not stretch it. Apply it directly off the roll onto clean panels. Ensure that all washers are flush with the panels and do not over-tighten screws, as this can crack the washers. Silicone caulking may be used to create watertight seals at the washers and throughout the building.

Q. What kind of base do I use?

A. You can:

- Use an Arrow Base Kit
- Pour a concrete slab
- Build a wood deck/floor (use exterior-grade plywood)
- Use patio blocks
- Build on crushed gravel, dirt or grass

Arrow provides a base kit accessory that is an option for most building sizes. If you are building a wood deck/floor, an Arrow floor frame kit on top of your deck/floor assembles in minutes and provides a floor frame suitable for a 5/8" exterior-grade plywood floor (not included). A continuous unbroken plastic vapor barrier with a thickness of 6 mil. between the ground and the building's base is also recommended.

Q. How should I measure for my base?

A. Shed dimensions are provided in "nominal" size. Nominal sizes are roof-edge measurements rounded to the nearest foot and are not the measurements to use for constructing the shed base. So, carefully check the exact, recommended base size in the specifications for your shed model.

Q. How do I align the holes in the wall panels with the holes in the floor frame?

A. Make sure that the shed is level and square, with the correct floor frame size, and that the corner panels are installed correctly. Line up the large hole in the panel with the small holes in the floor frame. An awl can be used to help align the holes.

Q. How do I align the holes in the roof panels with the holes in the roof beam and side wall angles?

A. Your building must be level and square in order for the holes to align. It must be square at both the top and bottom. Check that the building is square by measuring diagonally. The two diagonal measurements will be equal. If your building is out of square, carefully rock and push the shed until it is square. Also, try loosening the roof beams to give more play and flexibility. Non-alignment can also occur if your building is not level. You can raise corners and shim under them to make it level. Check that the panels are installed in the proper location. The building should not be permanently anchored until the complete unit is assembled; otherwise, you will not be able to make adjustments for squareness during assembly. Do not attach the bottom of the roof panels to the side wall angles until all the roof panels are up.

Note: If you have to stop assembly for any reason before it is complete, do not leave your unfinished construction without first temporarily anchoring the corners of the shed to your base and placing weights, such as patio blocks or sandbags, on the floor frame.

Q. How do I ensure that the sliding doors on the building will hang level?

A. Make sure that the door track has been correctly installed, with the long leg on top and the short leg on the bottom. Check that the door slides are straddling the upper and lower legs of the door track assembly, putting the door slide only halfway in the track. Also, the rounded end of the door slide should be at the bottom and the square end at the top.

Q. What kind of customer support is available?

A. Our instruction manuals contain step-by-step assembly illustrations and guide you from preparation through assembly to care and maintenance of your finished building. Each part is marked with a factory number for easy identification. In addition, our assembly animation (located under the Customer Support menu on the website) provides helpful tips. But if you need to reach someone at Arrow, you can contact Arrow Customer Service, toll free, at 1-800-851-1085 (press 1) or via e-mail at assist@arrowsheds.com. Have your model number and instruction manual with you when you call.

Q. What if the rear wall angle and channels are too large to fit inside of the rear wall panels?

A. Check the dimensions of wall assemblies. They should be slightly smaller than the floor frames. Lay the assemblies on top of the rear floor frame and pull them up to the top of the wall panels causing the corner panels to stand erect and not lean inward. Caution: Be careful to not scratch the panels on the way up.

Q. The wide rib always overlaps the crimped rib. Is there ever an exception?

A. This sequence is to be followed through the assembly process. However, this will typically happen once on the rear and once on each side wall (vertical wall units only) where there will be either two crimped ribs overlapping or two wide ribs overlapping. This may give it a tighter fit, but it will work.

Q. Can the building be painted?

A. The buildings can be painted with an exterior-grade paint designed for use on steel. Contact your local paint supplier for recommendations.

Q. I heard that rust might be an issue with steel; is it?

A. While steel can rust, with proper care this should not be an issue. For a long-lasting finish, periodically clean the exterior surface and apply spray-on car wax. Touch up scratches as soon as you notice them by immediately cleaning the area with a wire brush or emery paper, washing it and applying touch-up paint. This will minimize rust and maintain your shed's attractive appearance for years.

Q. How do I take care of dents in my shed?

A. Proper selection of shed size, including a sufficient door-opening width, and proper placement of your shed should minimize the possibility of damage. If a dent does occur, carefully push the dent out from the opposite side. If the paint has been scratched or removed, touch up the area as soon as you notice it. Immediately clean the area with a wire brush or emery paper, wash it and apply touch-up paint. This will minimize rust and maintain your shed's attractive appearance for years.

Still have questions? Visit us online at www.arrowsheds.com to view lots of helpful tips and information regarding all of our available products. You can also contact our Customer Service team at 1-800-851-1085 (press 1), or via e-mail at assist@arrowsheds.com.

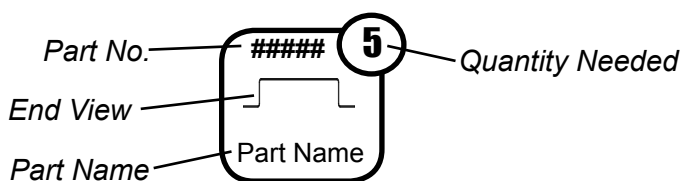

At the top of each page you will see one or more **Part Cues** like the one to the left. These **Part Cues** are designed to help you quickly identify the parts needed for each step.

Confirm that all hardware and parts are present before attempting to assemble your building.

For missing or damaged parts contact Customer Service. Do not return to store.

Customer Service:

1-800-851-1085 or
assist@arrowsheds.com

Part Numbers

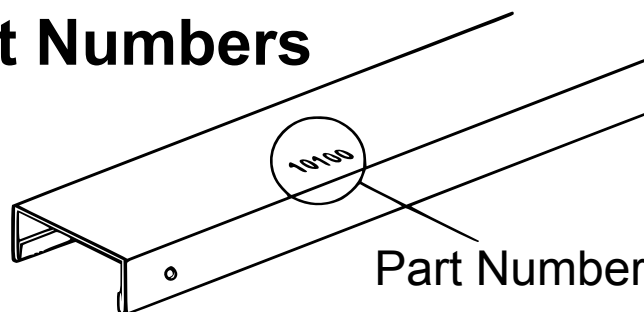

1. Each part has an identifying part number on it.
2. Part Numbers are referenced in each step.
3. Unpainted parts have a stamped in number and painted parts have a number that is inked on.

Remove inked on numbers with soap and water after assembly.

HARDWARE LIST...

Key No.	Part No.	Part Description	Qty.	✓ List
1	65103	Hex Nut (#8-32)	69	
2	65923-33	Small Bolt (Sand) (#8-32 x 3/8) (10 mm)	31	
3	65923-18	Small Bolt (Java) (#8-32 x 3/8) (10 mm)	26	
4	65004-33	Small Screw (Sand) (#8AB x 5/16) (8 mm)	116	
5	65004-18	Small Screw (Java) (#8AB x 5/16) (8 mm)	40	
6	66783	Flat Head Bolt (#8-32 X 1/2) (13 mm)	12	
7	65958	Long Bolt (#8-32 X 7/8) (22 mm)	2	
8	66692	Tapping Screw (#10ABx1) (25 mm)	1	
9	66809	Locking Door Handle	1	
10	66054	Latch	1	
11	66609	Hinge	2	
12	66183L	Left Roof Trim Cap	2	
13	66183R	Right Roof Trim Cap	2	
14	66447	Peak Cap	2	
15	66646	Washer Sheet	4	
16	66812	Hinge Plate Decor	2	
17	66811	Handle Backplate	1	
18	67293	Weather Stripping	1	
19	67236	Adhesive Pad	1	

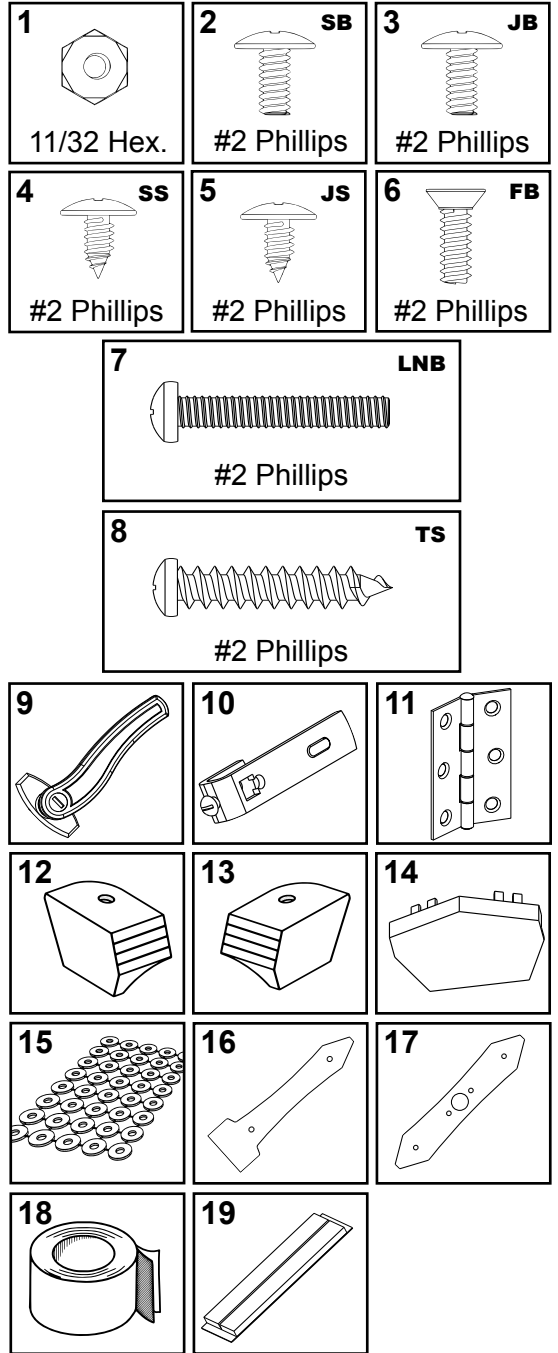

Various fasteners are used throughout the construction of your storage unit. In each step you will see the abbreviations listed used in the illustrations to help you identify which fastener to use.

- SB** - Sand Bolt
- JB** - Java Bolt
- LNB** - Long Bolt
- TS** - Tapping Screw
- SS** - Sand Screw
- JS** - Java Screw
- FB** - Flat Head Bolt

The fasteners used in each step are shown actual size at the top of each page. If you are unsure which fastener to use, hold it up to the picture and use the one that matches.

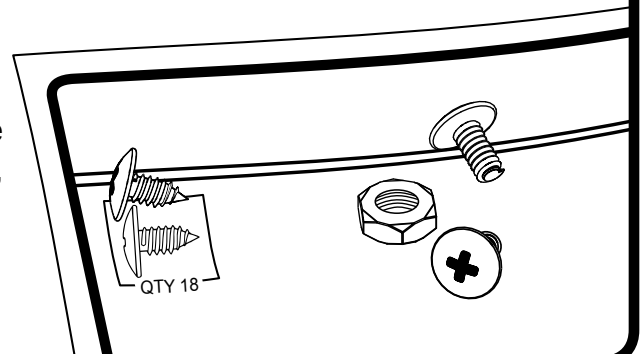

PARTS LIST...

Key No.	Part No.	Part Description	Qty.	✓ List
1	10743	Front & Rear Floor Section	2	
2	10744	Floor Section	5	
3	10741	Front & Rear Floor Channel	2	
4	10742	Side Floor Channel	2	
5	10701	Rear Corner Panel	2	
6	10726	Front Corner Panel	2	
7	10716	Right Door Jamb	1	
8	80057	Left Door Jamb	1	
9	10740	Side Wall Channel	2	
10	10739	Rear Wall Channel	1	
11	10731	Side Wall Angle	2	
12	10729	Rear Wall Angle	1	
13	10732	Front Header	1	
14	10725	Wall Panel	4	
15	10734	Right Gable	2	
16	10735	Left Gable	2	
17	10733	Gable Brace	2	
18	10738	Roof Beam	2	
19	66820	Gable Decor	1	
20	69835	Edge Trim (Green)	2	
21	9204	Roof Beam Brace	2	
22	10730	Right Roof Panel	2	
23	80061	Left Roof Panel	2	
24	10727	Roof Panel	1	
25	10728	Roof Panel	1	
26	10737	Ridge Cap	1	
27	10736	Side Roof Trim	2	
28	10782	Door	1	
29	10718	Horizontal Door Brace	2	
30	10719	Door Handle Brace	1	
31	10720	Diagonal Door Brace	4	

Selected End Views by Key No.

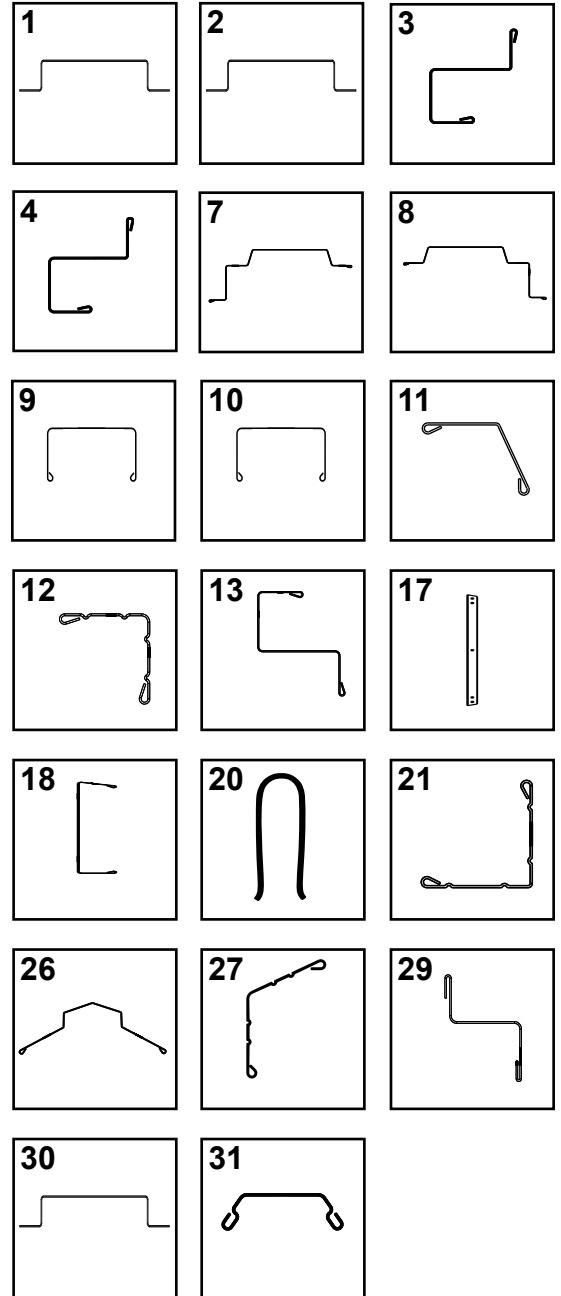

ASSEMBLY BY KEY NO.

Walls

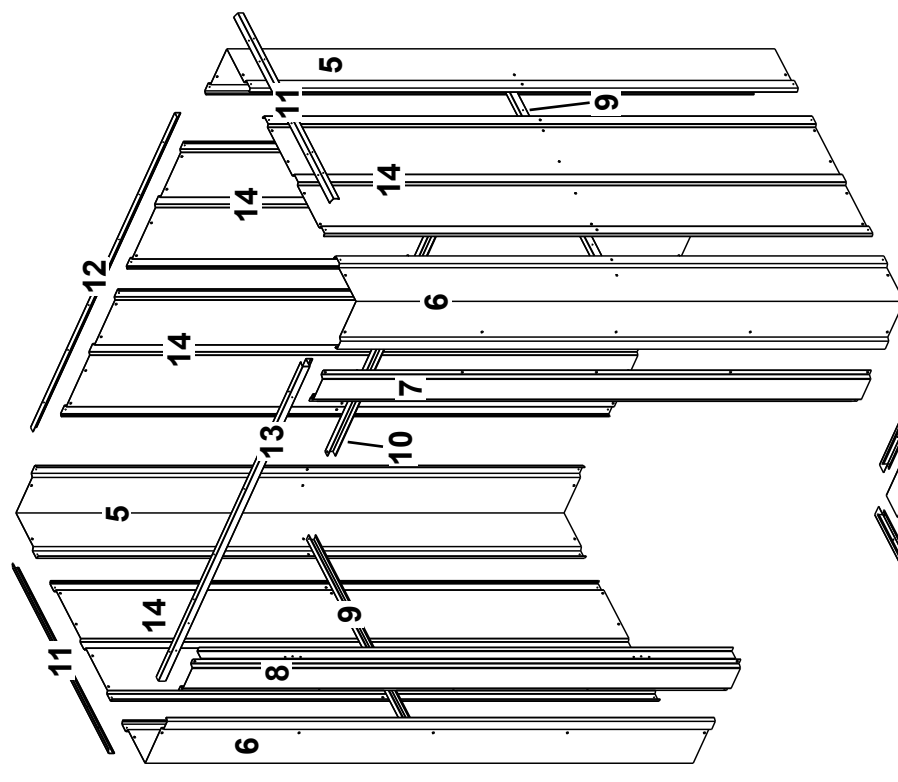

Roof

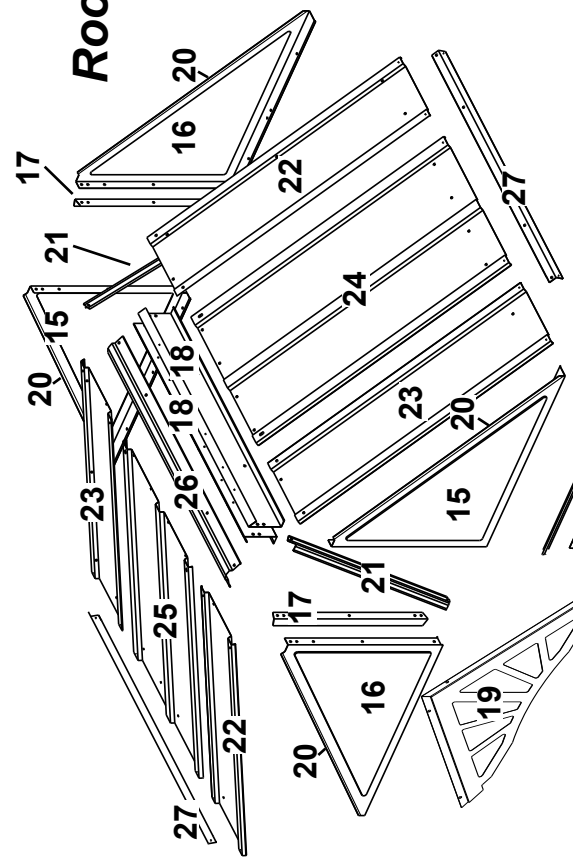

Floor

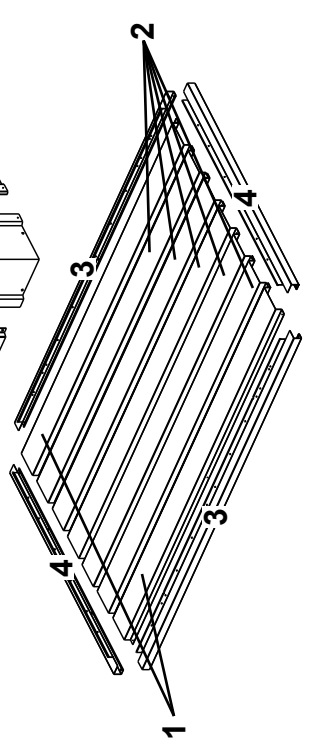

Door

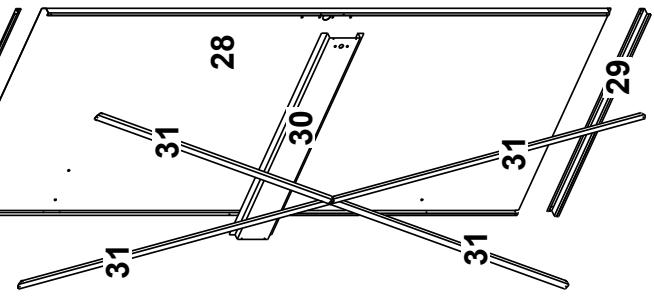

ASSEMBLY OVERVIEW

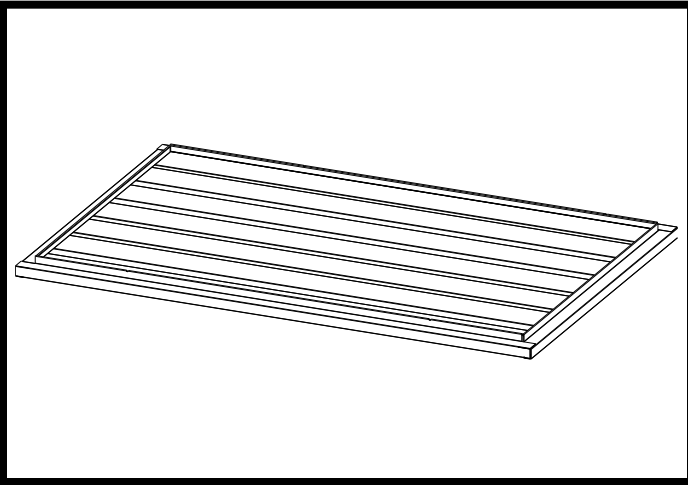

Build the Floor Frame

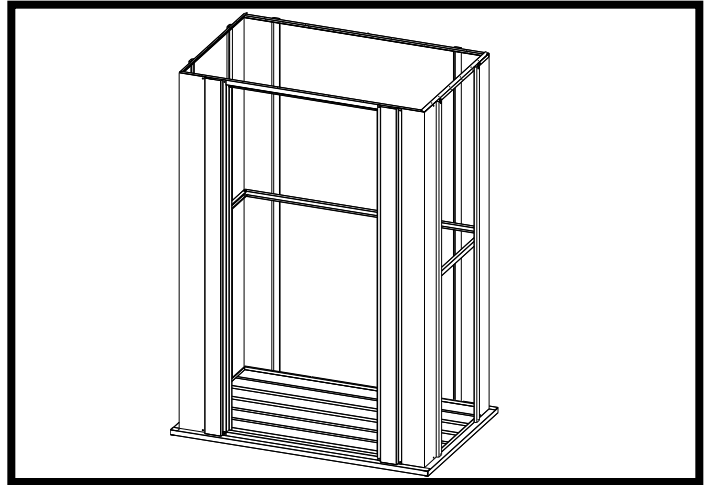

Install Corner Panels, Wall Angles, Wall Channels, Door Jamb and Front Header

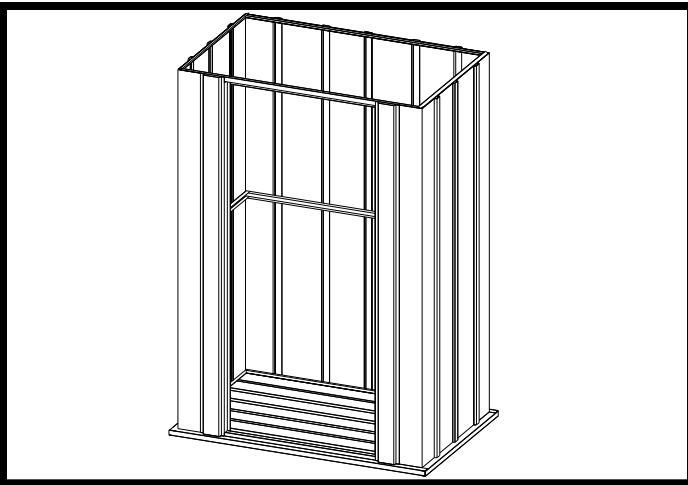

Install Wall Panels

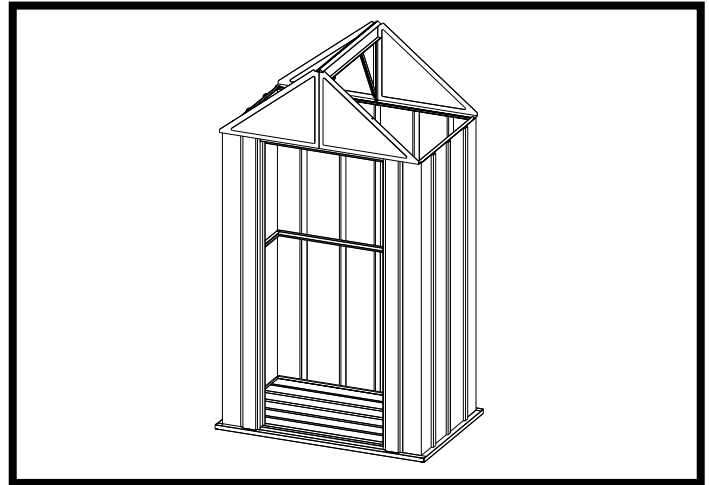

Attach Gables and Roof Beams

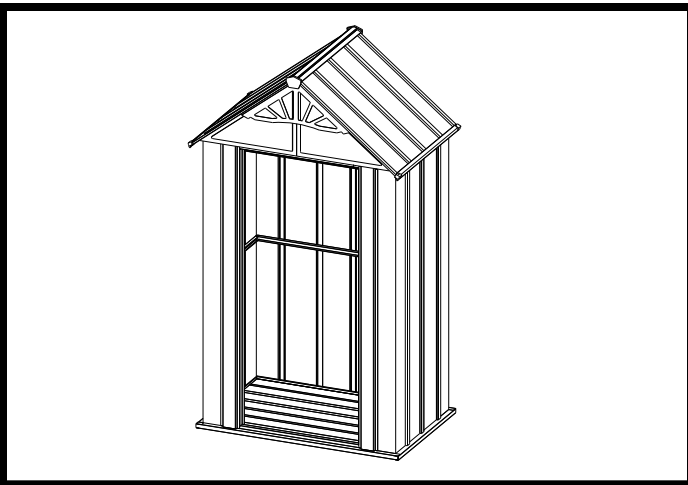

Install Roof Panels, Decorative Gable Piece, Ridge Cap, Side Trim, and Corner Caps

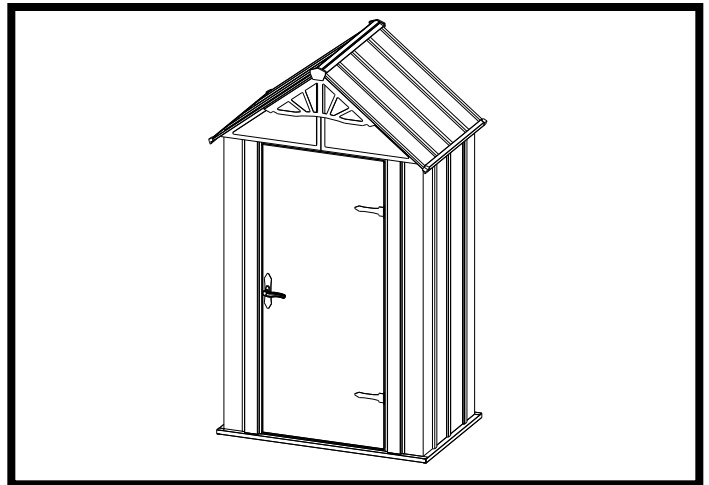

Install Doors

Shed is now complete.

Step 1: Floor

You will need for this page:

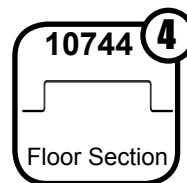
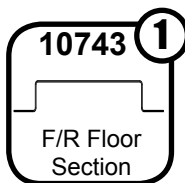
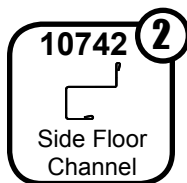
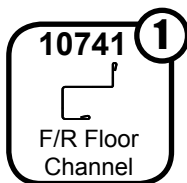
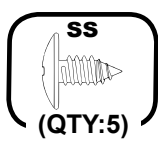
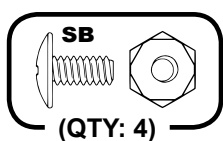

- 1** Attach one (1) **Front/Rear Floor Section** to a **Front/Rear Floor Channel** securing with one (1) **Sand Screw** as shown.

- 2** Attach **Side Channels** securing with one (1) **Sand Screw** at each corner.

The Front and Rear Floor Section should be aligned with the Front and Rear Floor Channels as shown.

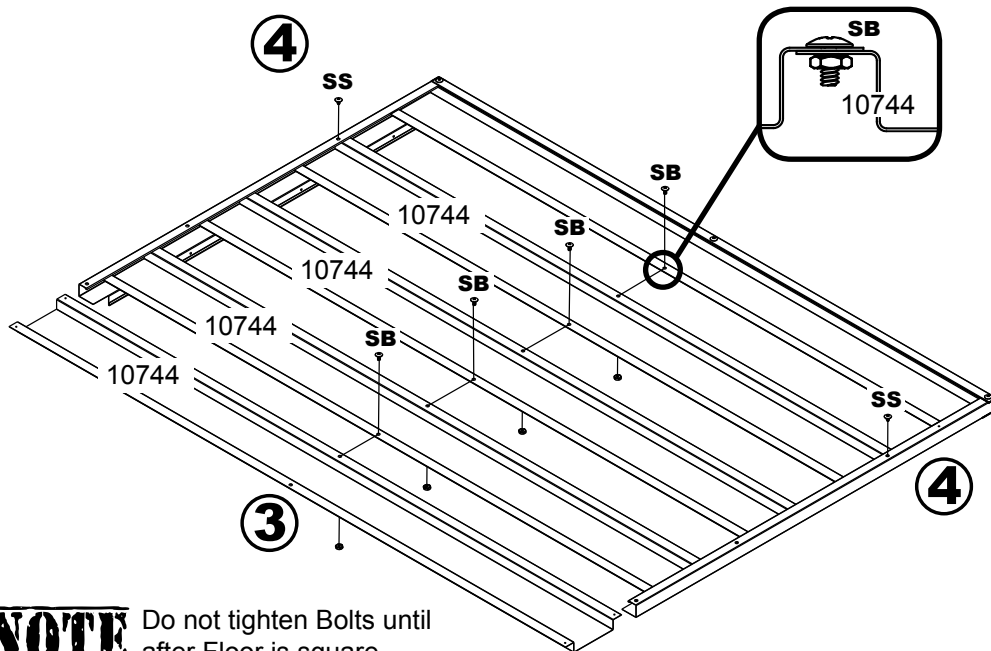
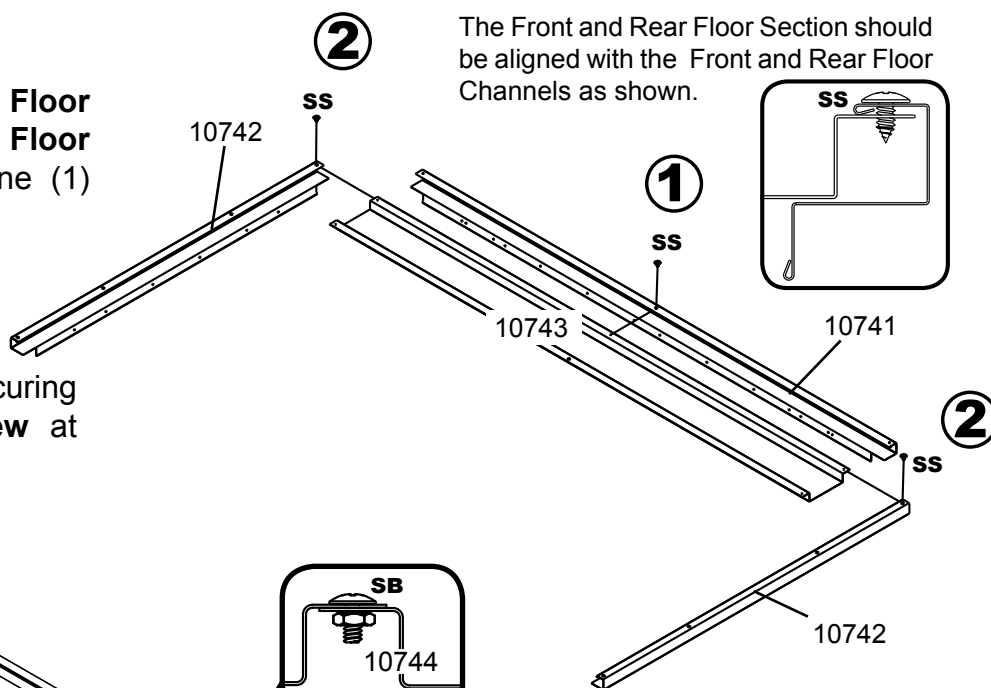

Floor Channels overlap as shown.

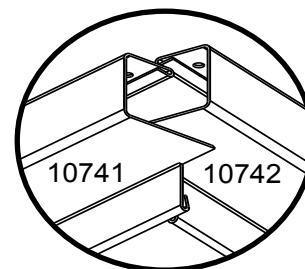

NOTE Do not tighten Bolts until after Floor is square.

- 3** Slide four (4) **Floor Sections** into the **Side Channels** one (1) at a time. Secure in the middle using four (4) **Sand Bolts** and **Nuts** as shown.

- 4** Secure ends of **Floor Sections** to the **Side Channels** using two (2) **Sand Screws** as shown above.

Step 1: Continued

You will need for this page:

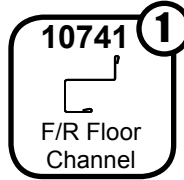
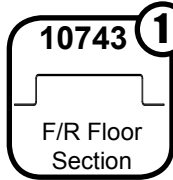
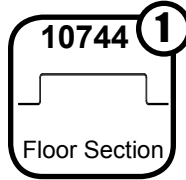
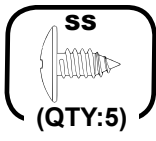
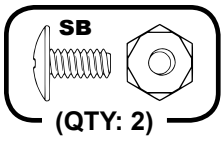

- 5** Slide **Floor Section** and **Front/Rear Floor Section** into place. Secure using two (2) **Sand Bolts** and **Nuts** at the middle.

- 6** Secure ends of **Floor Section** to the **Side Channels** using two (2) **Sand Screw** as shown above.

- 7** Attach **Front/Rear Floor Channel** using three (3) **Sand Screws** as shown.

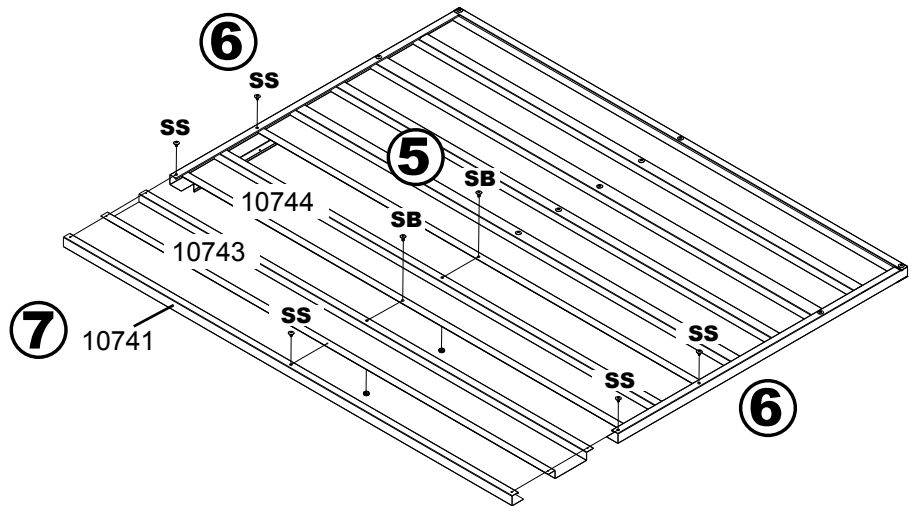

- 8** Once **Floor** is complete, turn completed floor over. At this time, take a moment to ensure the unit is level and square. Measure diagonally, when the diagonal measurements are equal, the **Floor** is square.



IMPORTANT: IF STORAGE UNIT IS NOT SQUARE, DOOR WILL NOT CLOSE PROPERLY!

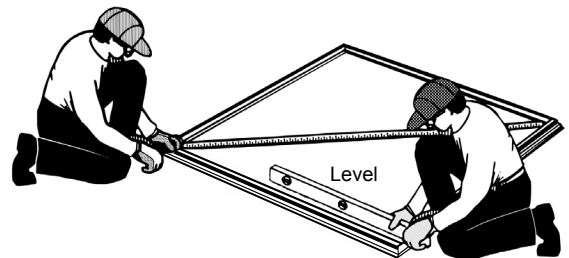

NOTE After Floor is square, tighten bolts holding Floor Sections together.

Step 2: Front Corners and Door Jamb

You will need for this page:

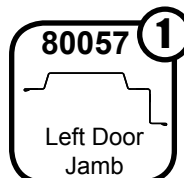
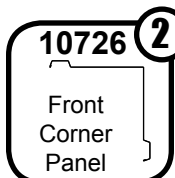
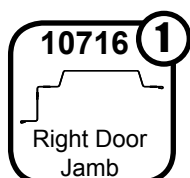
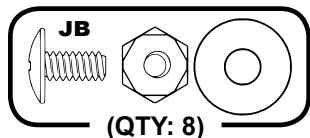

- ① Attach the **Front Corner Panels** to the **Right and Left Door Jambs** using three (3) **Java Bolts and Nuts (#1-3)** for each **Panel**. Place one (1) **Java Bolt and Nut (#4)** in center hole of **Door Jamb** as shown.

NOTE Washers are to be used on painted parts only. Washers are not necessary on unpainted parts and there are not enough to use on every Screw and Bolt.

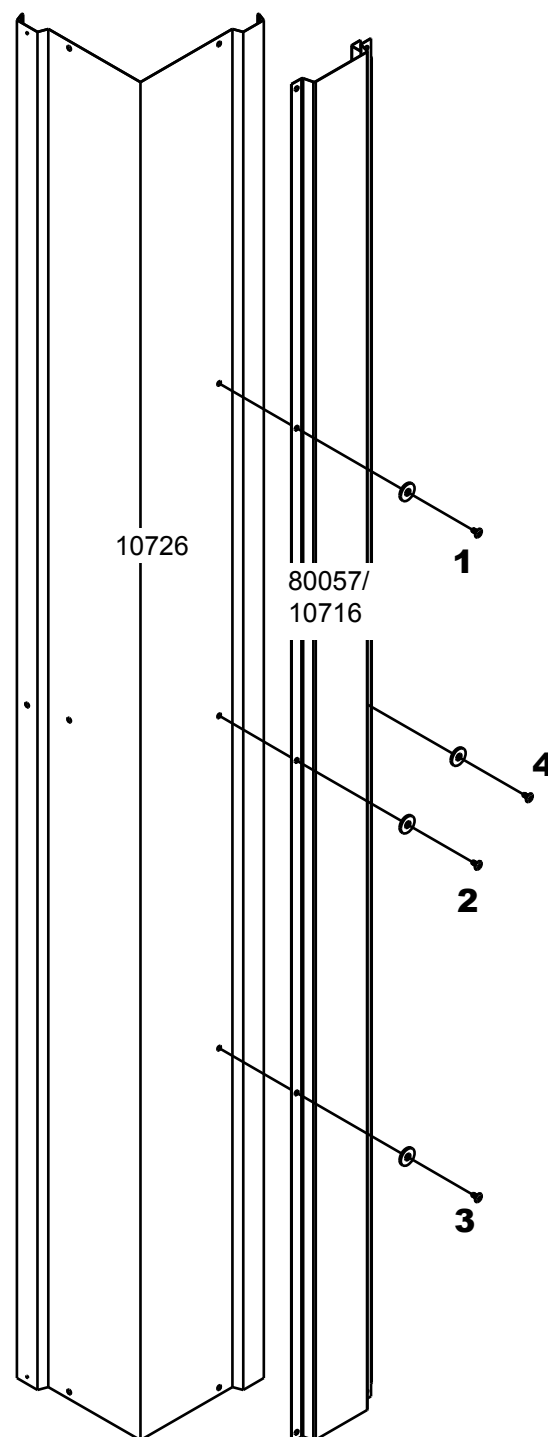

Step 3: Wall Framing

You will need for this page:

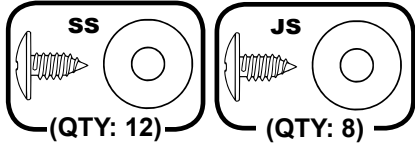

Assemblies from Step 2:

- Front Right Corner Assembly
- Front Left Corner Assembly

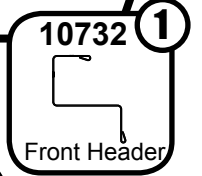
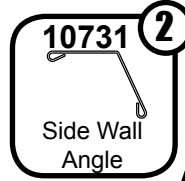
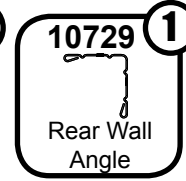
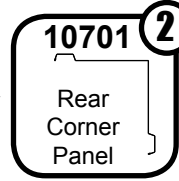

1 Attach the **Rear Corner Panels** to the **Floor Frame** using two (2) **Sand Screws** for each **Panel**.

2 Attach the **Rear Wall Angle** to the **Rear Corner Panels** using one (1) **Sand Screw** in each **Panel**.

NOTE Leg of Rear Wall Angle with six holes facing up.

3 Attach the **Front Corner Assemblies** to the **Floor Frame** using one (1) **Sand Screw** on the side of the building and two (2) **Java Screws** on the front of the building for each assembly as shown.

4 Attach the **Side Wall Angles** to the **Rear and Front Corner Panels** using one (1) **Sand Screw** in each **Panel**. **Side Wall Angles** overlap **Rear Wall Angle** in corners.

5 Place the **Front Header** on top of the **Door Jambs**, under the **Side Wall Angles** in the corners. Secure **Front Header** with two (2) **Java Screws** at the top of each **Door Jamb** as shown.

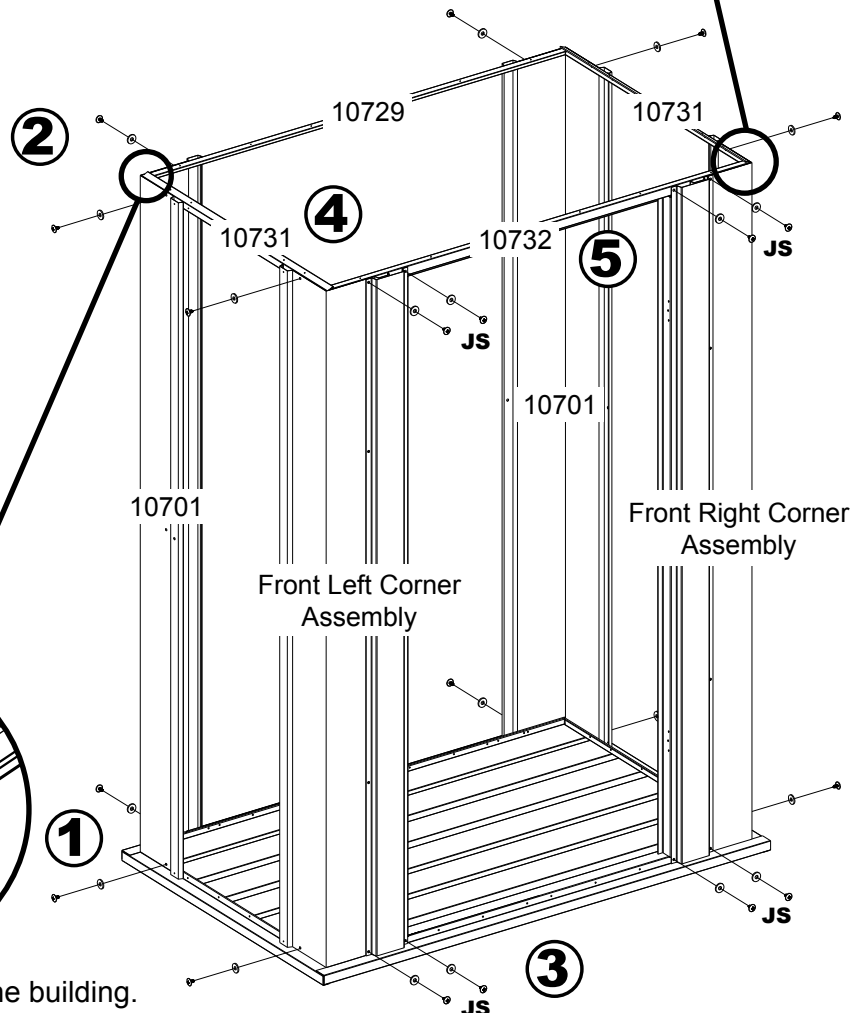
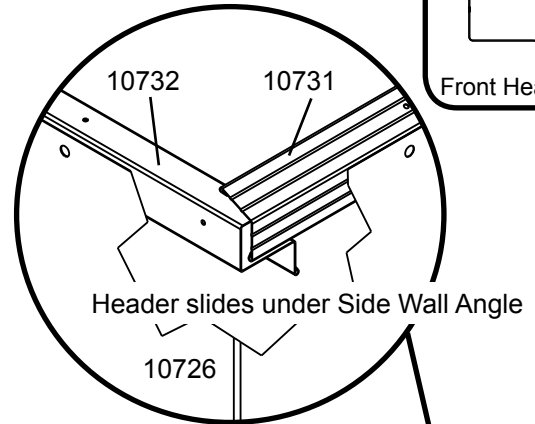

NOTE Support the Corner Panels until Wall Angles are installed.

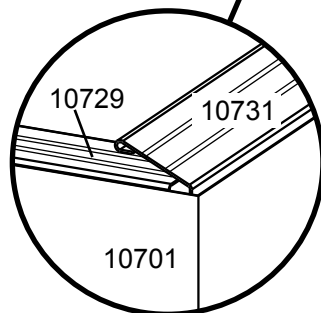

Wall Angles must face inside the building.

Step 4: Wall Panels

You will need for this page:

[NO HARDWARE NEEDED FOR THIS STEP]

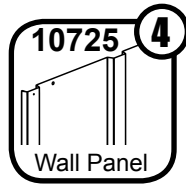

1 Lay out all **Panels** in the positions shown below. Double check that you have the correct **Panel** in each location.

NOTE

Use the diagram to the right when attaching Wall Panels.

- Secure the top row to Wall Angles.
- Secure the middle row to Wall Channels (Step 5).
- Secure the lower row to Floor Frames.
- Secure the circled holes to the Panel next to it.

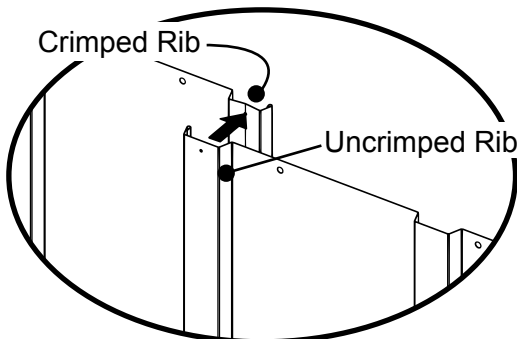
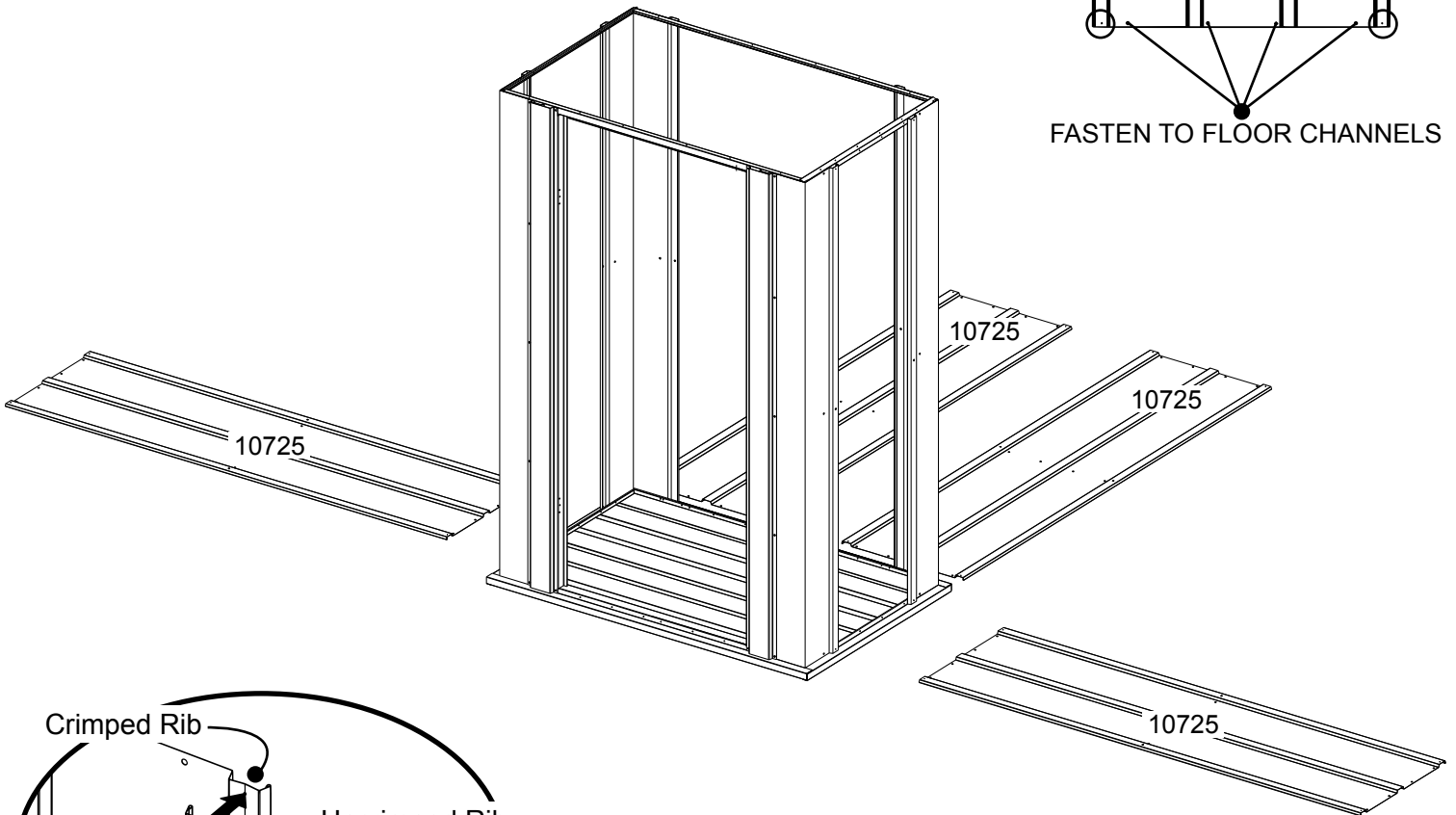
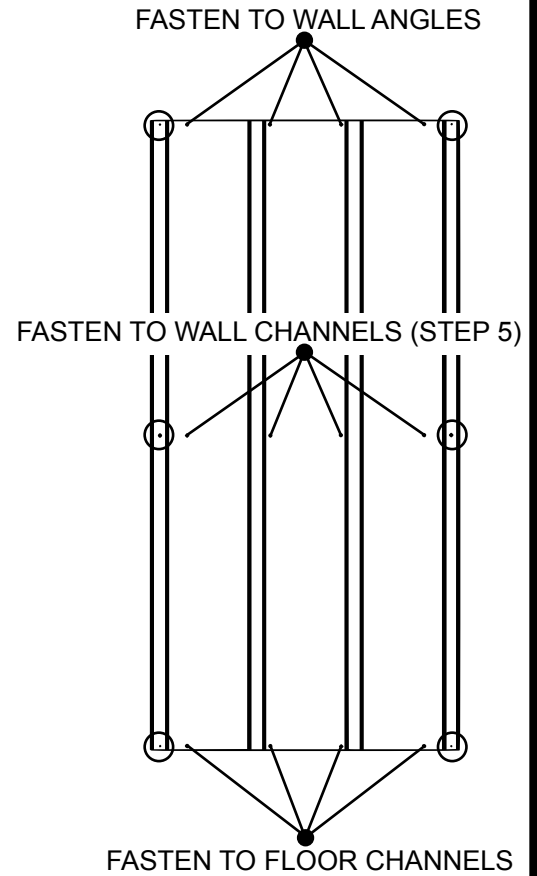

Whenever a crimped rib and an uncrimped rib meet, the crimped rib should be placed UNDER the uncrimped rib if possible.

Step 4: Continued

You will need for this page:

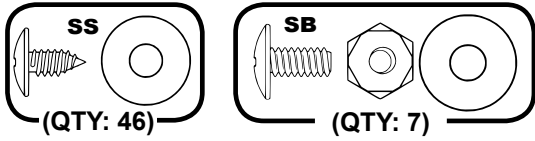

2 Working one side at a time, lift the **Panels** into place and secure top and bottom of **Panels** with **Sand Screws**.

3 Place one (1) **Sand Bolt** and **Nut** through the center hole of the **Panel** where **Panels** overlap, as shown.

Continue until ALL Wall Panels have been installed.

NOTE Corner Panels lay over Back and Side Panels.

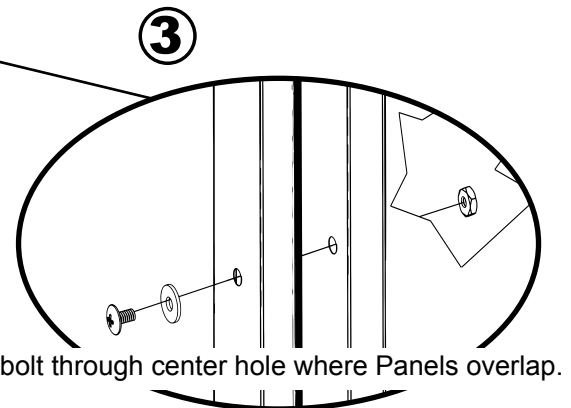
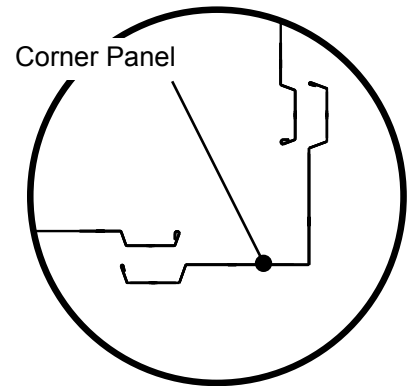
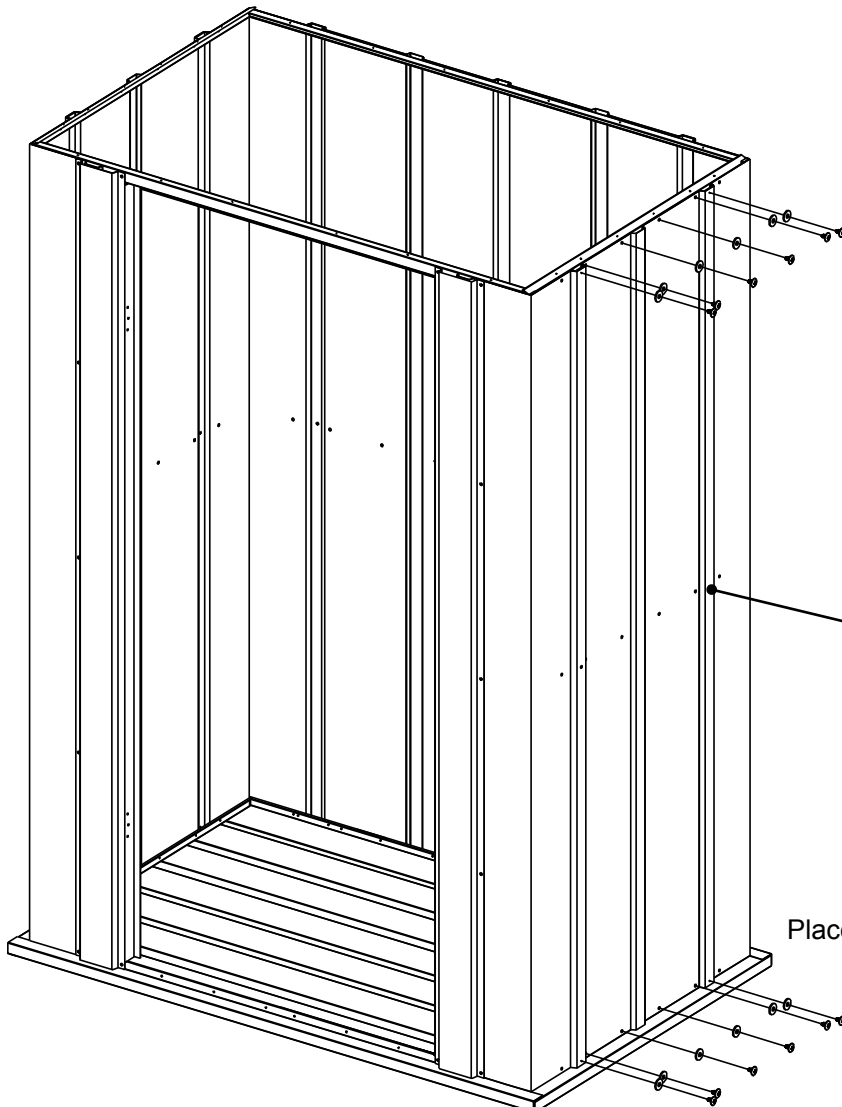

Place bolt through center hole where Panels overlap.

Step 5: Wall Channels

You will need for this page:

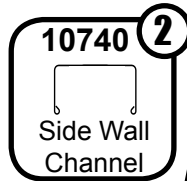
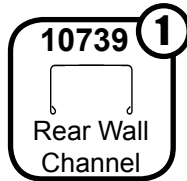
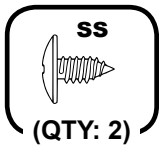
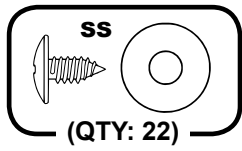

- 1** Install **Rear Wall Channel** by placing **Sand Screws** through all remaining holes in **Rear Wall Panels**.
- 2** Install **Side Wall Channel** by placing **Sand Screws** through all remaining holes in **Side Wall Panels**.
- 3** Insert a **Sand Screw** in both rear corners where **Side and Rear Wall Channels** meet.

3

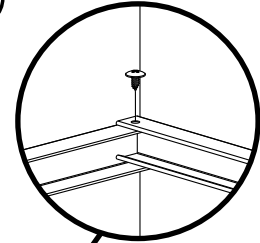

Insert screw where Channels meet.

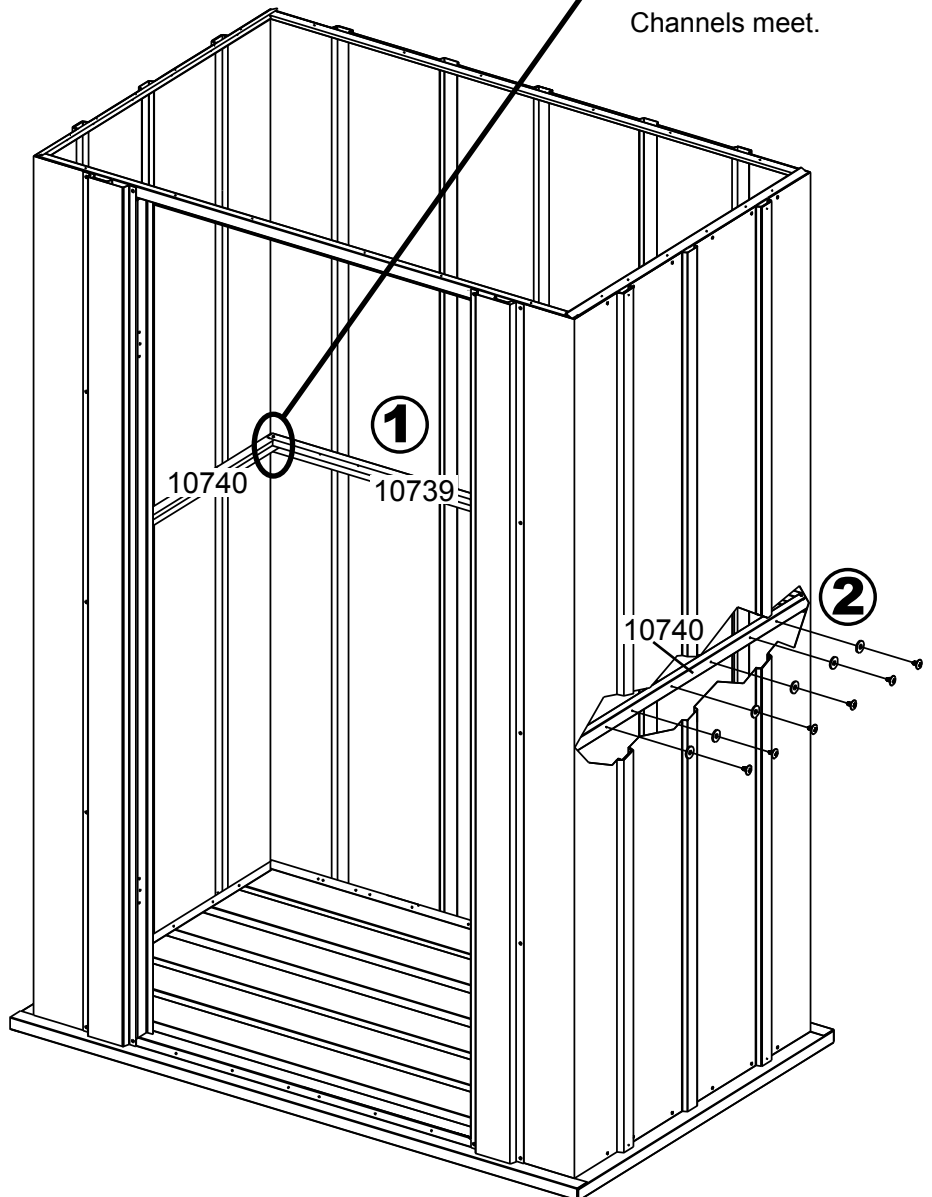

Step 6: Gables

You will need for this page:

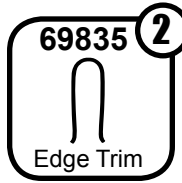
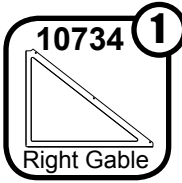
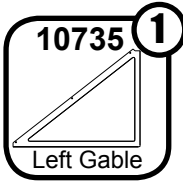
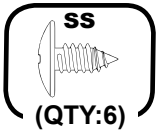

STOP GABLES ARE STACKED TOGETHER DURING SHIPPING AND MAY BE MISTAKEN FOR ONE GABLE! SEPARATE GABLES BEFORE CONTINUING.

! *Install Edge Trim to cover Gable Edge BEFORE doing ANY work with Gables. Failure to do so could result in injury.*

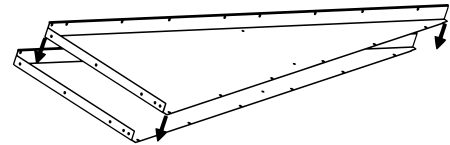

1 Cut **Edge Trim** in half to make four (4) **Edge Trim** pieces. Install **Edge Trim** to top edge of **Gables** as shown.

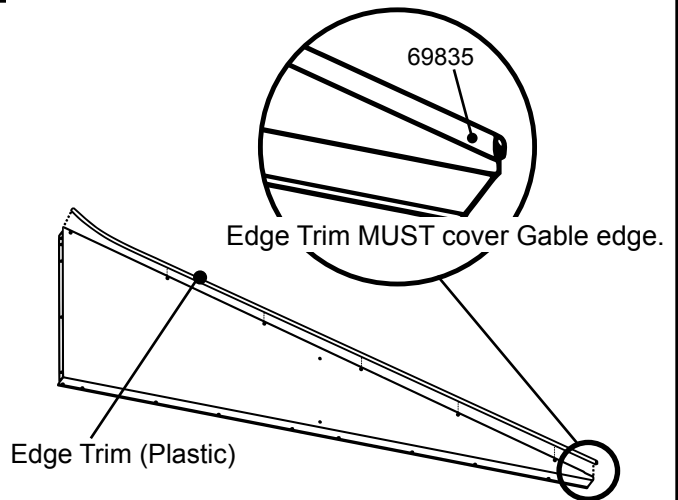

2 Working one (1) **Gable** at a time, attach the **Rear Gables** to the **Rear Wall Angle** with three (3) **Sand Screws** as shown.

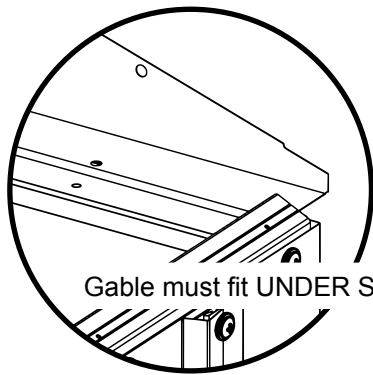

Gable must fit UNDER Side Wall Angle at corner.

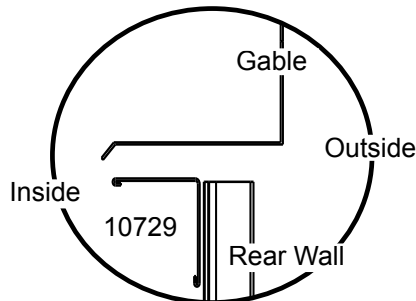
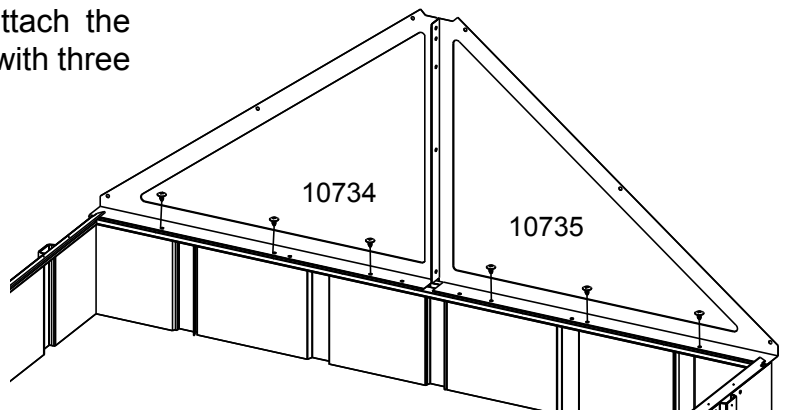

Step 6: Continued

You will need for this page:

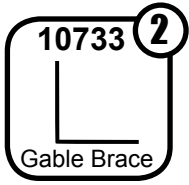
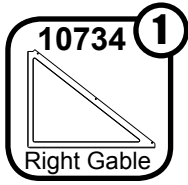
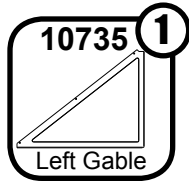
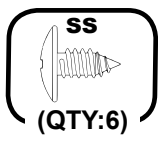
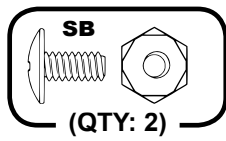

3 Working one (1) **Gable** at a time, attach the **Front Gables** to the **Header** with six (6) **Sand Screws** as shown.

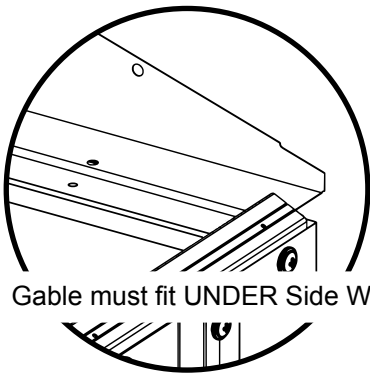

Gable must fit UNDER Side Wall Angle at corner.

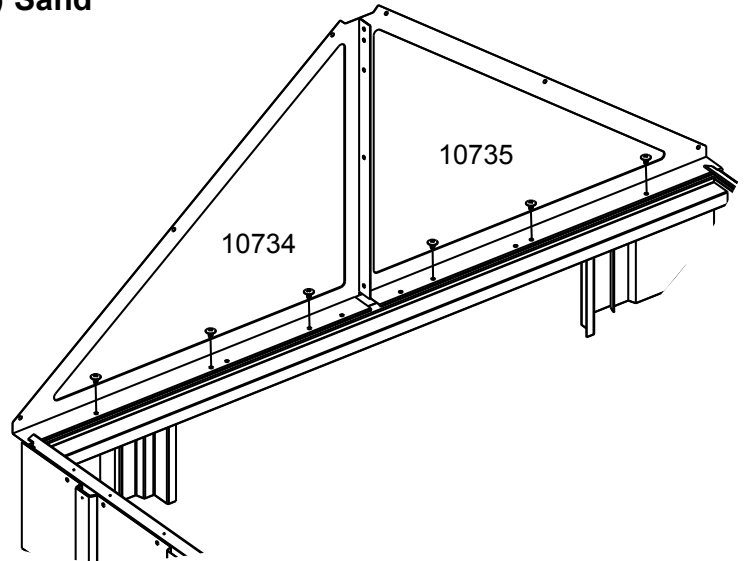

4 To secure **Left** and **Right Gables** together, position the **Gable Brace** as shown to the right and insert a single **Sand Bolt** and **Nut** through the second hole from the bottom only. Repeat this for the other set of **Gables**.

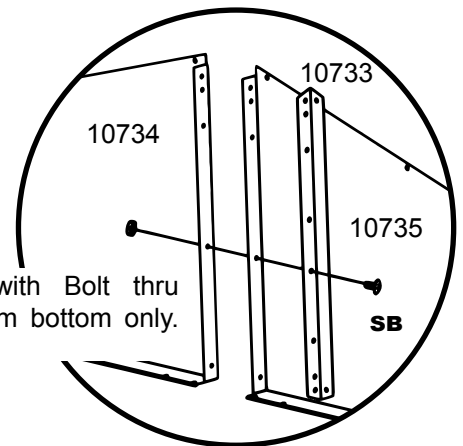

Attach Brace with Bolt thru second hole from bottom only.

5 Seal the gap between the **Gables** using the **Weather Stripping Tape** as shown. Do this for both set of **Gables**.

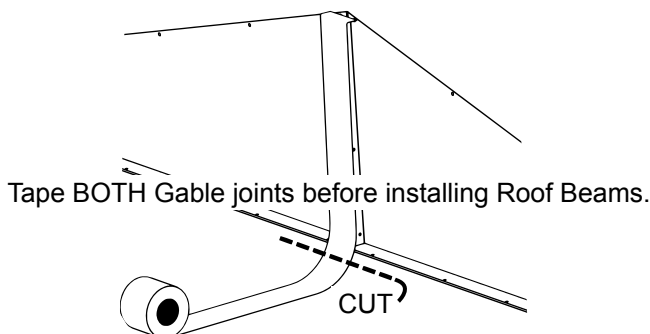

Tape BOTH Gable joints before installing Roof Beams.

Top View of Gables

Tape should wrap around gap between Gables.

Weather Stripping Tape

Step 6: Continued

You will need for this page:

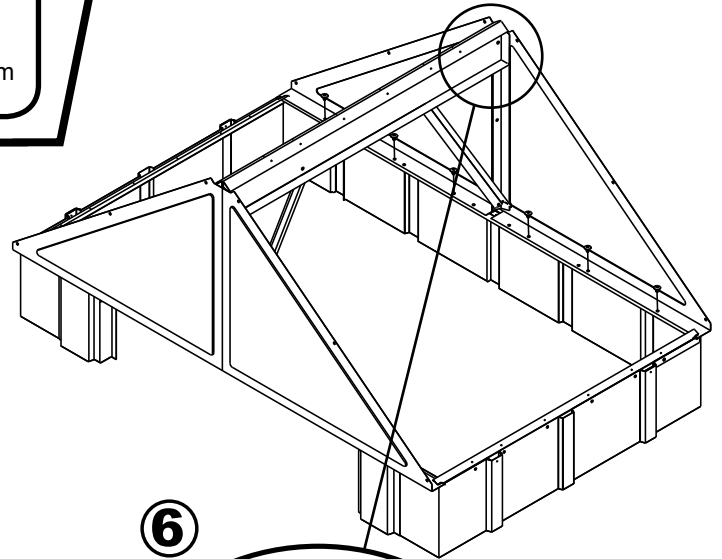
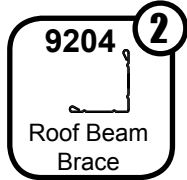
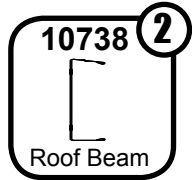
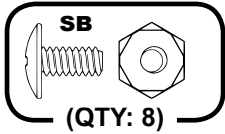

6 Position the **Roof Beams** at the top of **Gables** as shown and attach using two (2) **Sand Bolts** and **Nuts** on each side of **Roof Beams**.

7 Attach the angled end of **Roof Beam Brace** to the **Gable** with one (1) **Sand Bolt** and **Nut** as shown.

8 Rotate to align with **Roof Beam** and secure to **Roof Beam** with one (1) **Sand Bolt** and **Nut** as shown. Repeat for opposite side.

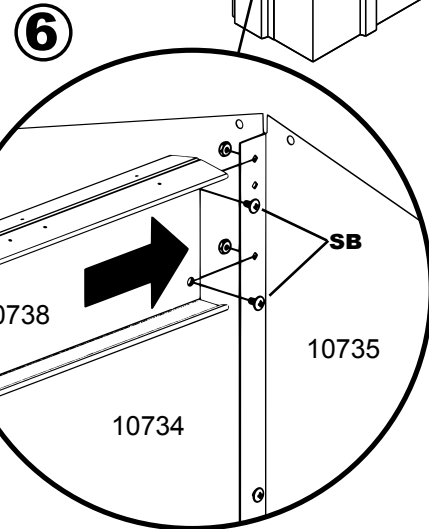

Tab on Roof Beam Bracket mounts between Main Roof Beam.

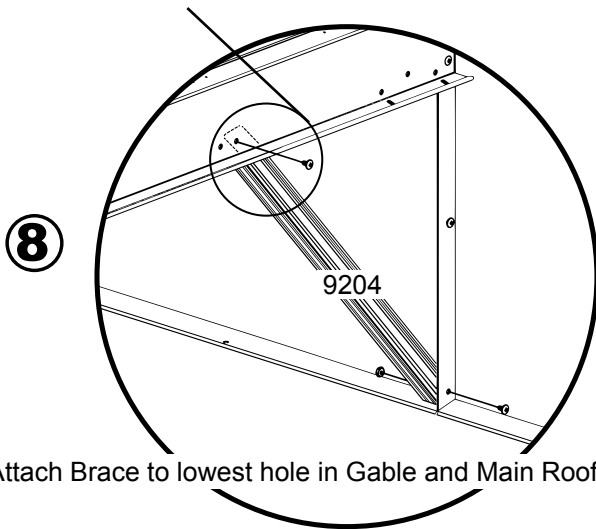

Attach Brace to lowest hole in Gable and Main Roof Beam.

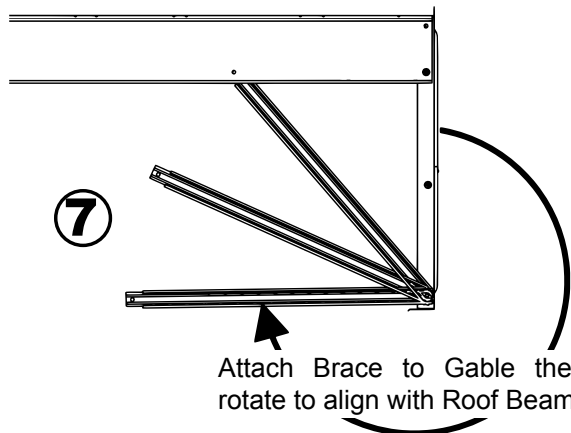

Roof Install Prep Page

Read through all of Step 7 before beginning Roof Assembly.

At this time, measure diagonally to ensure the building is square. The building should be square at the base and at the top. This will make Roof Panels fit better and holes will better align.

NOTE Be sure to carefully follow the Roof Panel Placement Order Diagram on this page.

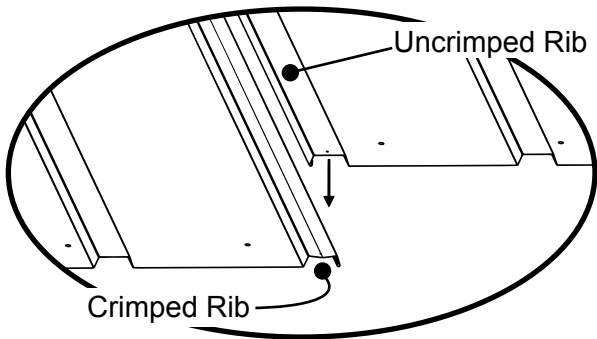

Whenever a crimped rib and an uncrimped rib meet, place the crimped rib UNDER the uncrimped rib.

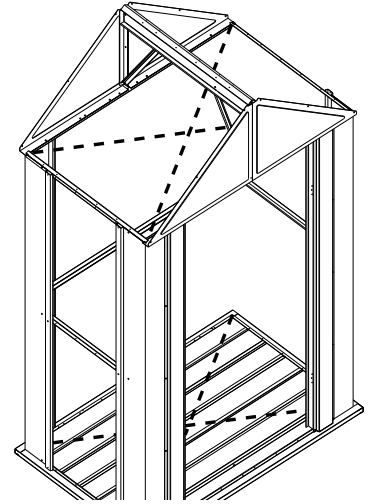

The building is square when diagonal measurements are equal.



Roof Panel Placement Order

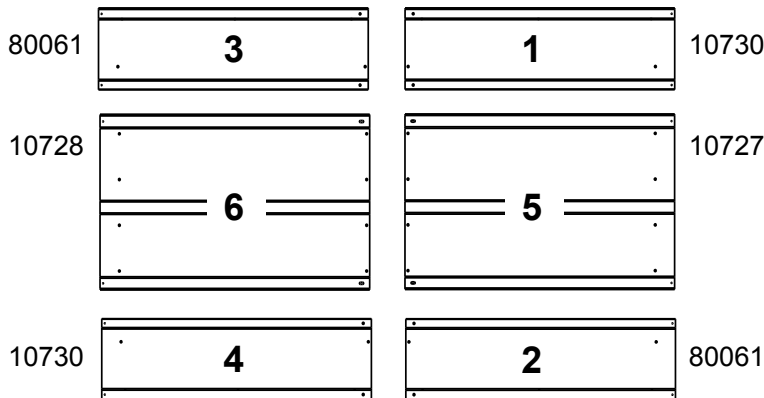

FRONT

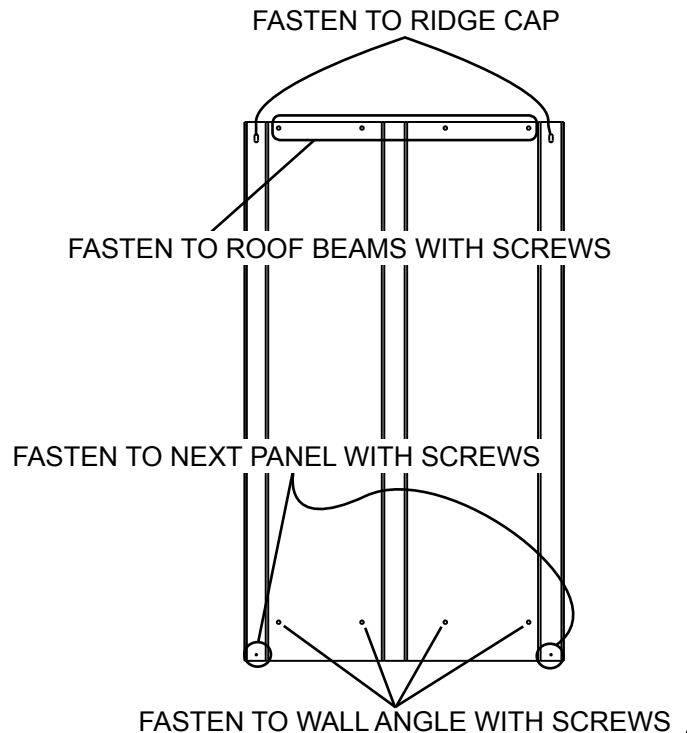

Step 7: Roof

You will need for this page:

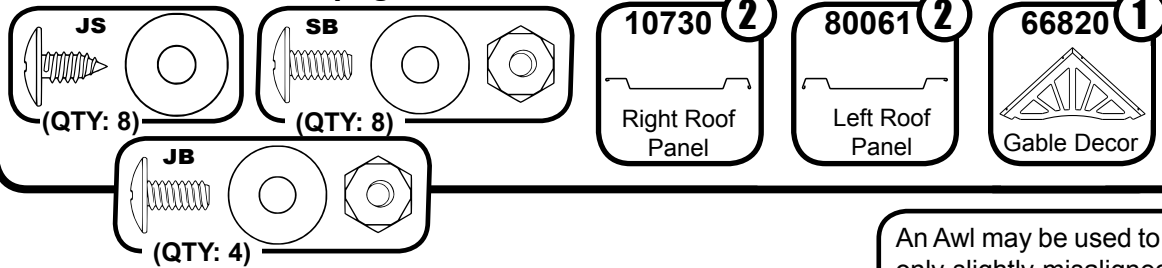

An Awl may be used to help align holes that are only slightly misaligned. Take care not to bend or warp the metal, and always practice proper tool safety.

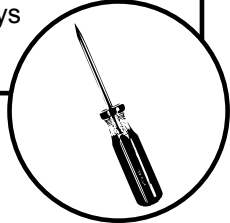

1 Secure each of the four (4) **Roof End Panels** to the **Roof Beam** and the **Side Wall Angles** by placing one (1) **Java Screw** in hole #1 and one (1) **Java Screw** in hole #2 (see diagram below). Carefully remove the **Gable Edge Trim** once the **Panels** are in position.

2 Fasten the back **Roof End Panels** to the **Gables** by placing three (3) **Sand Bolts** and **Nuts** through holes #3 - #5. Fasten the holes in order. Fasten the front **Roof End Panels** using one (1) **Sand Bolt** and **Nut** at the bottom hole **only**.

NOTE If Roof Beam holes do not line up with Roof Panel holes, shift the building from left to right. If this does not help, your building may not be level. Shim the corners until holes line up.

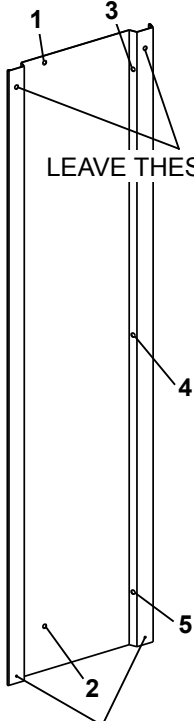

LEAVE THESE HOLES OPEN

LEAVE THESE HOLES OPEN

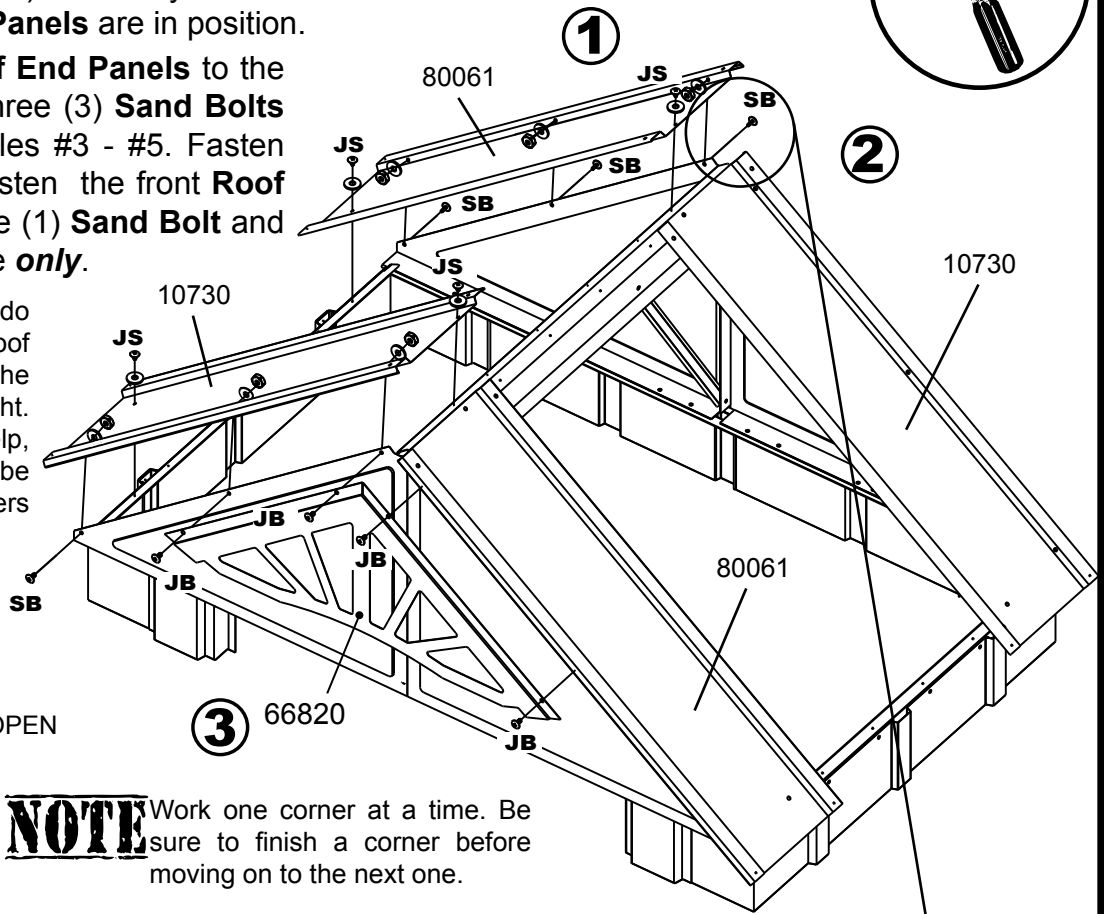

NOTE Work one corner at a time. Be sure to finish a corner before moving on to the next one.



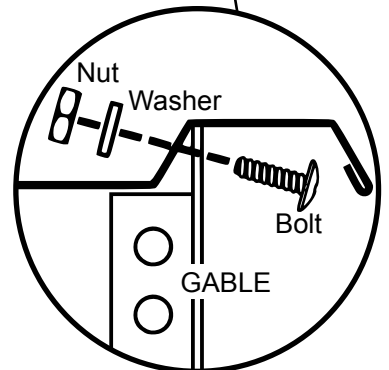

3 Finish securing front **Roof End Panels** with **Gable Decor** to **Gables** using four (4) **Java Bolts** and **Nuts** as shown above.

NOTE When securing the Gable Decor, be careful not to scratch the paint. Do not use a drill to tighten the Nuts. Instead, use a No. 2 Phillips Screwdriver to hold the Bolt in place and a Nut Driver or Wrench to tighten the Nut.

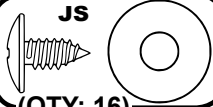

Step 7: Continued

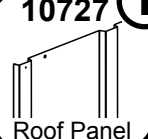
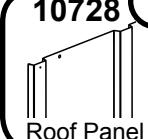
You will need for this page:

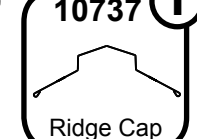
 <p>JS (QTY: 16)</p>	 <p>JB (QTY: 4)</p>	 <p>10727 1 Roof Panel</p>	 <p>10728 1 Roof Panel</p>	 <p>67293 1 Weather Stripping</p>	 <p>10737 1 Ridge Cap</p>
--	---	---	--	--	--

4 Attach each of the two (2) middle **Roof Panels** (#5 - #6) to the **Roof Beam** and the **Side Wall Angle** using eight (8) **Java Screws** as shown.

5 Seal the roof ridge by applying **Weather Stripping** across the entire roof ridge as shown.

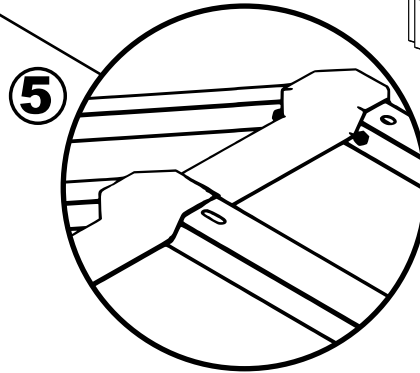
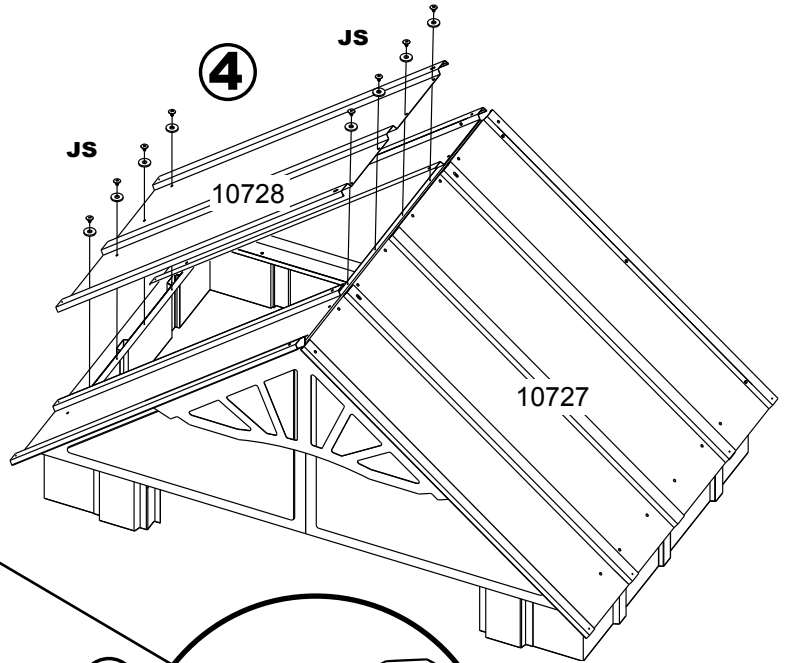
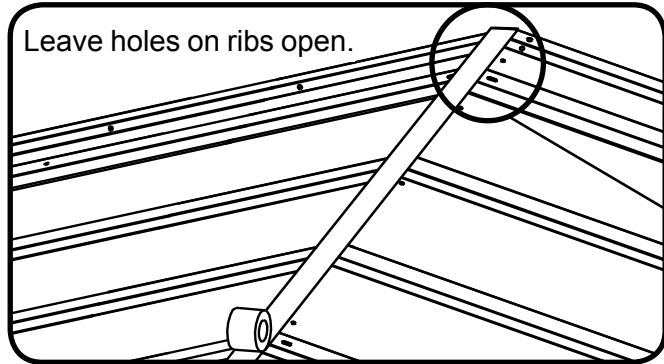

NOTE Weather Stripping Tape should be applied in a continuous strip along the length of the roof.

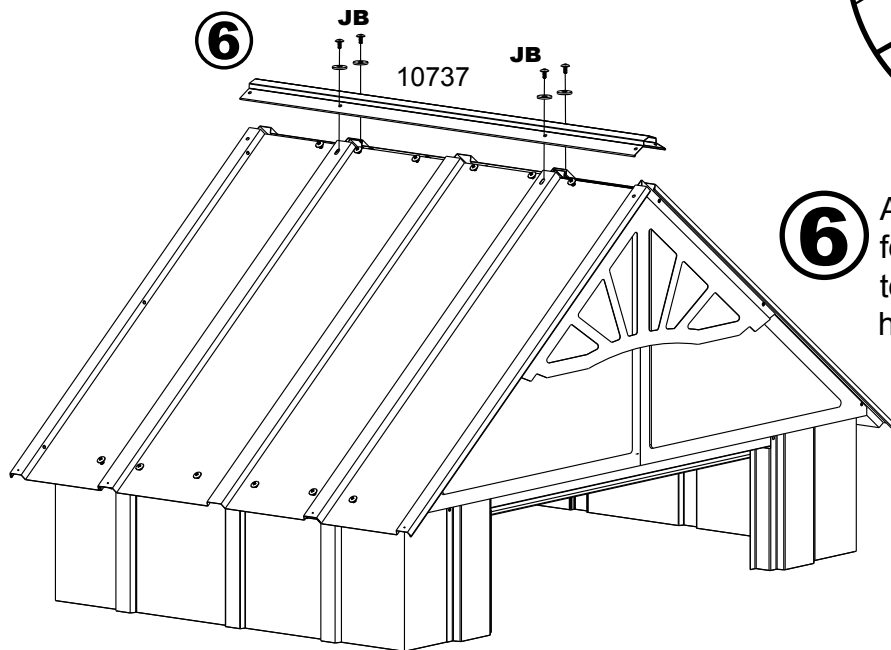





6 Attach the **Ridge Cap** to the **Roof** using four (4) **Java Bolts** and **Nuts** as shown to the left. Do not place **Bolts** in the end holes of the **Ridge Cap**.

NOTE DO NOT fully tighten Ridge Cap Bolts until Peak Caps are installed. This will ease assembly.

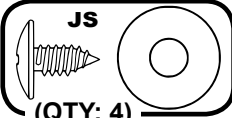
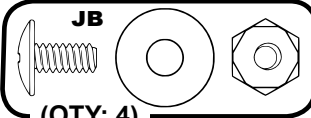
Step 8: Roof Trim

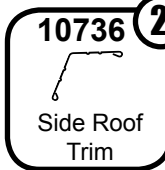
You will need for this page:

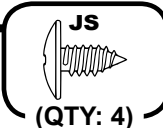
 <p>JS (QTY: 4)</p>	 <p>JB (QTY: 4)</p>	 <p>66447 2 Peak Cap</p>	 <p>10736 2 Side Roof Trim</p>	 <p>66183L 2 Corner Cap, Left</p>	 <p>66183R 2 Corner Cap, Right</p>
 <p>JS (QTY: 4)</p>					

1 Slide the **Peak Cap** legs under **Ridge Cap** and secure at each end with two (2) **Java Bolts** and **Nuts**.

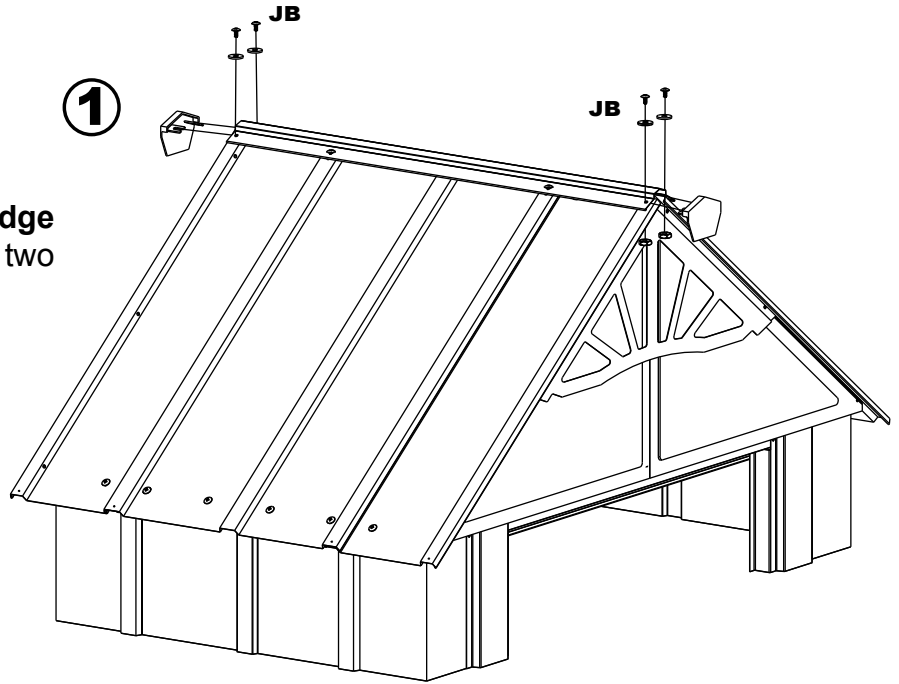

2 Position the **Side Roof Trim** as shown and secure with two (2) **Java Screws**. Leave each end hole open.

3 Position the **Left** and **Right Roof Trim Caps** as shown and secure with a **Java Screw**.

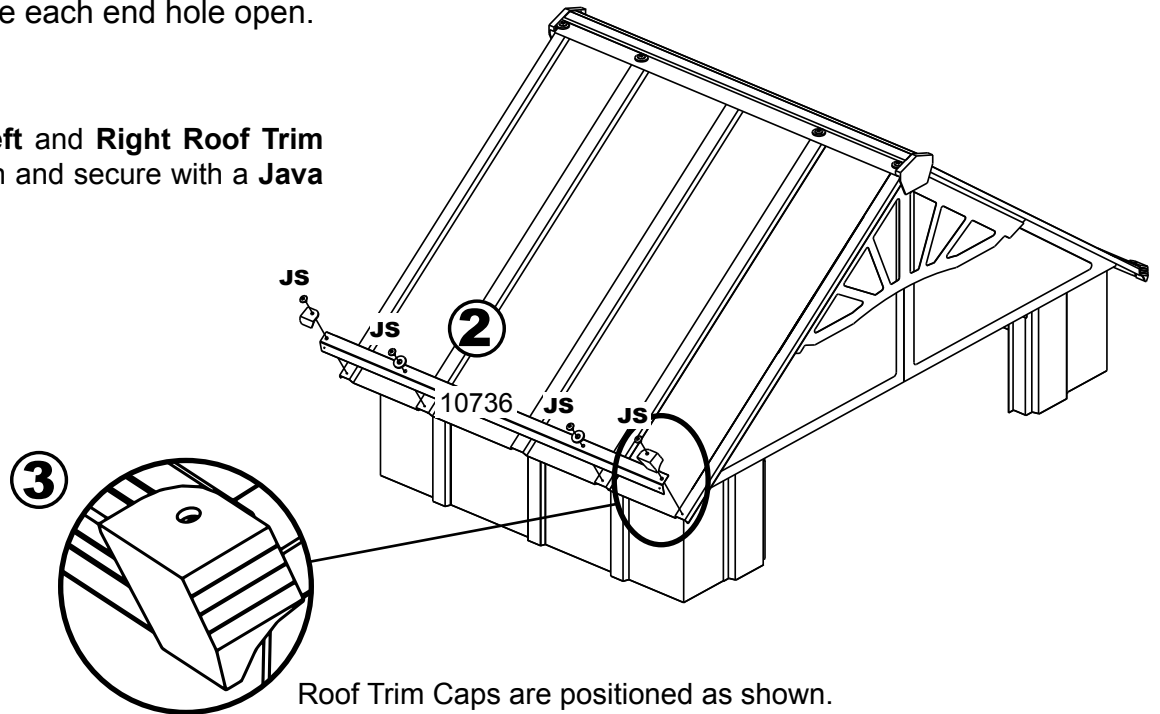

Roof Trim Caps are positioned as shown.

Step 9: Door Assembly

You will need for this page:

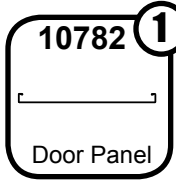
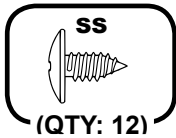
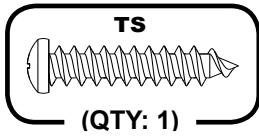

1 Start assembly by sliding the **Door Handle Brace** into the middle of the **Door** and securing it with four (4) **Sand Screws**. Then attach the **Horizontal Door Braces** to each end of **Door** using two (2) **Sand Screws** on each brace. Once installed, attach **Adhesive Pad** between leg of **Door Handle Brace** and **Door**.

2 Place the ends of **Diagonal Door Braces** with small holes under **Horizontal Door Braces** as shown. Secure all **Diagonal Door Braces** to center of **Door Handle Brace** using one (1) **Tapping Screw**. Attach all **Diagonal Door Braces** under **Horizontal Door Braces** using four (4) **Sand Screws** at each corner as shown.

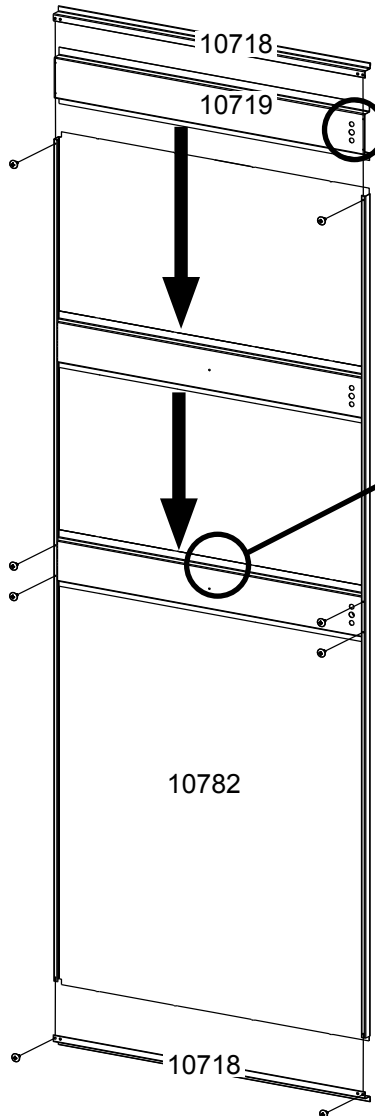

Make sure holes in Door Handle Brace are on same side as holes in Door.

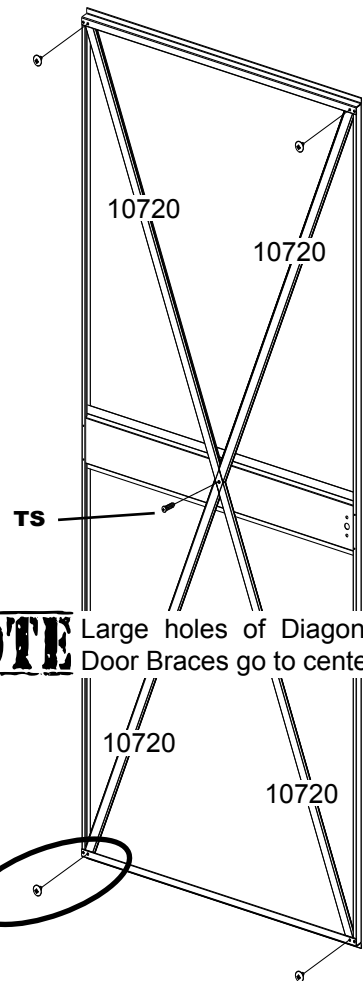
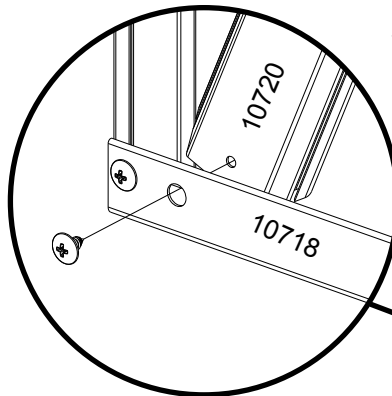
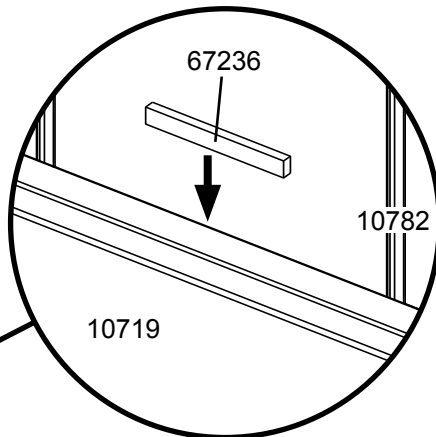

NOTE Large holes of Diagonal Door Braces go to center.

NOTE Diagonal Door Braces attach from behind Horizontal Door Brace.

Step 9: Continued

You will need for this page:

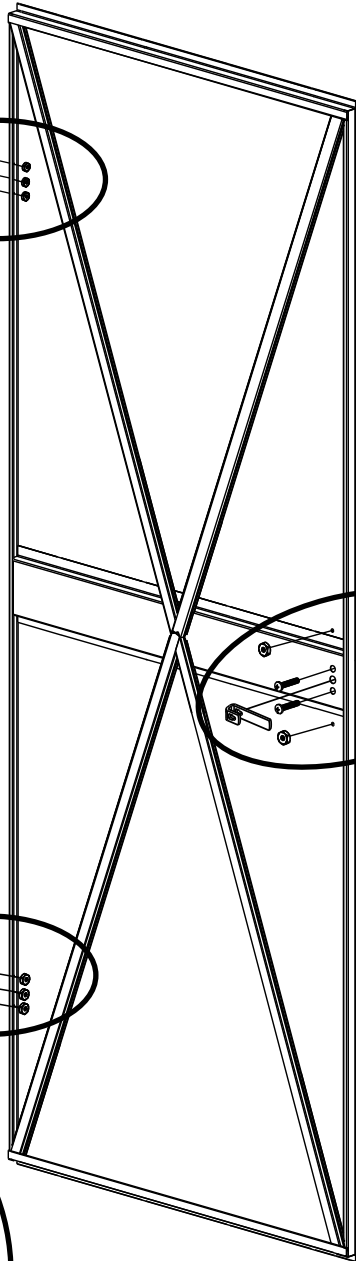
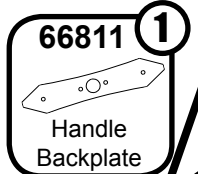
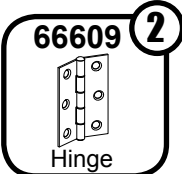
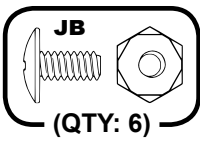
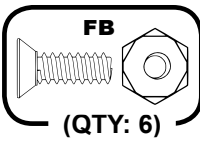
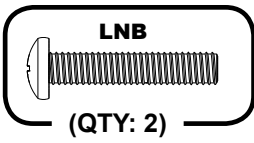

③ Attach **Hinges** to **Door** using six (6) **Flat Head Bolts**.

④ Install **Locking Handle** and **Handle Backplate** using two (2) **Long Bolts**. Secure **Backplate** using two (2) **Java Bolts** and **Nuts**.

⑤ Attach **Latch** to **Locking Handle**.

⑥ Tighten set screw in **Latch**.

⑦ Attach **Hinge Plate Decor** to **Door** by the **Hinges** using two (2) **Java Bolts** and **Nuts** for each **Decor**.

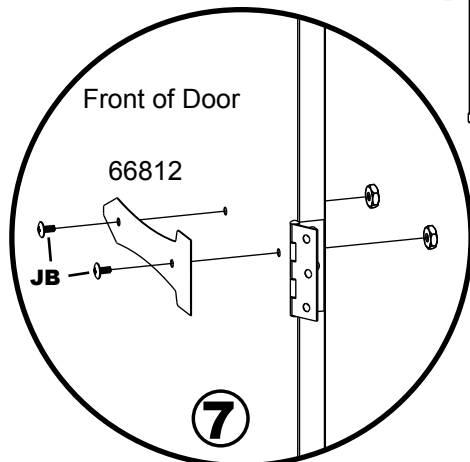
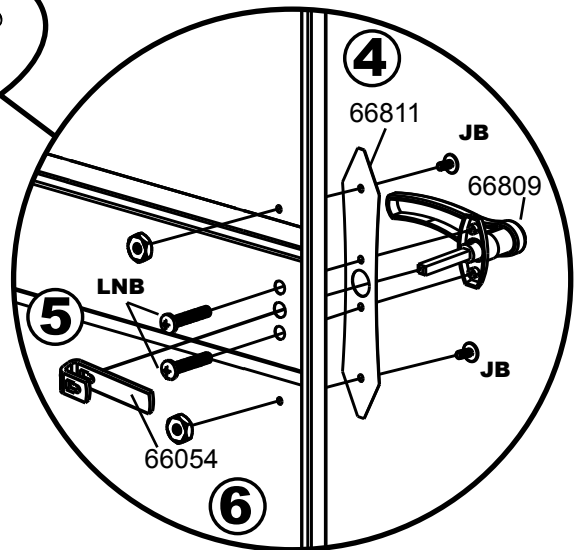
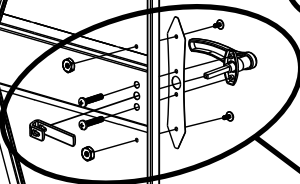
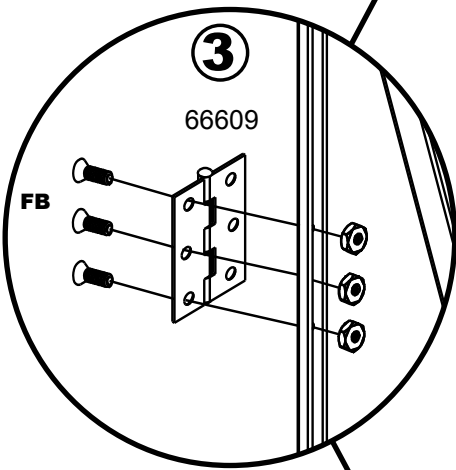

NOTE When securing the Decor, be careful not to scratch the paint. Do not use a drill to tighten the Nuts. Instead, use a No. 2 Phillips Screwdriver to hold the Bolt in place and a Nut Driver or Wrench to tighten the Nut.

Step 9: Continued

You will need for this page:

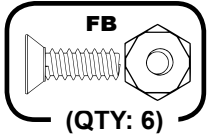

NEED AT LEAST TWO PEOPLE
TO PERFORM THIS STEP!

- 8** Hold **Door** up to **Door Jamb** and align holes on **Hinges** with holes on **Door Jamb**. Using six (6) **Flat Head Bolts**, secure **Door** to **Door Jamb**.

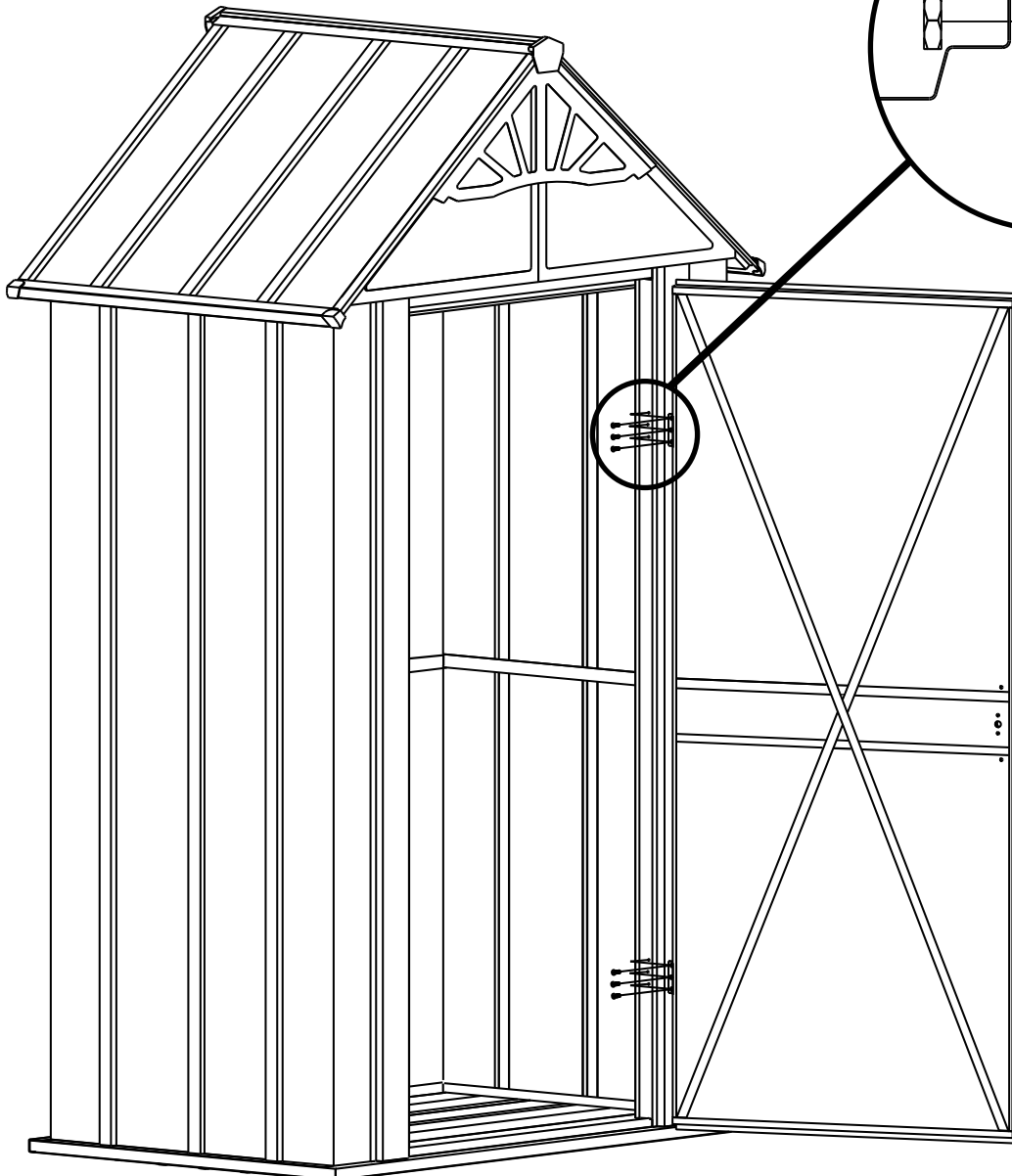

ANCHORING OPTIONS...

IMPORTANT:

- *If you have swing doors, they must hang and swing level before anchoring building.*
- *Anchor your building at this time. See below for details on anchoring.*
- *Please take a moment to ensure that the building is installed in accordance with these instructions and with all applicable regulations.*

Anchoring Down The Building

The entire floor frame **MUST** be securely anchored once the building is erected.

Below are recommended ways of anchoring.

Arrow Anchoring Kit: (Model No. AK4 or 60298)

Recommended for use with **any** suggested **base**.

Contains: 4 Anchors with Cable, Clamps and installation instructions.

Anchoring into Wood/Post:

Use 1/4" (6 mm) Wood Screws. There are 1/4" (6 mm) dia. holes provided in the frames for proper anchoring.

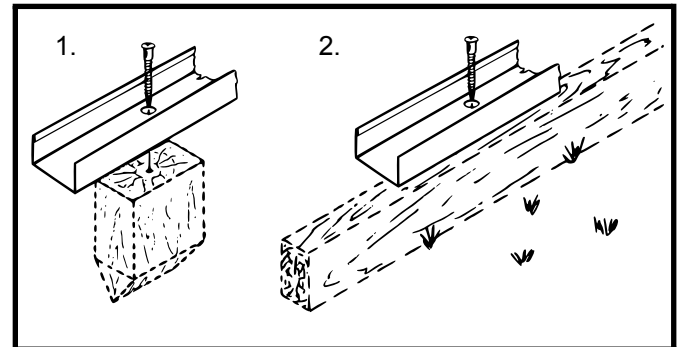
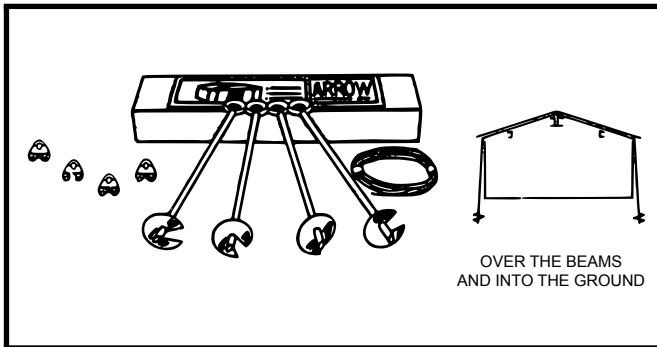

Anchoring into Concrete:

1. For poured concrete slab or footing or patio blocks:
Use 1/4" x 2" (6 mm x 51 mm) Lag Screws.

2. For Anchor Post of Concrete poured after building is erected: Use 1/4" x 6" (6 mm x 152 mm) Lag Screws.

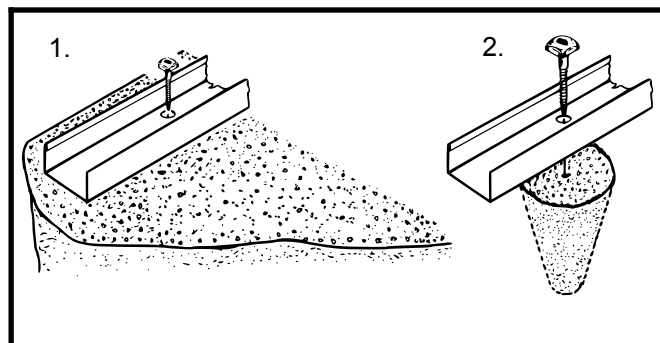

An Anchor Kit may be purchased online at www.arrowsheds.com
You can also purchase one over the phone by calling 1-800-851-1085.
See accessories page for details.

CARE & MAINTENANCE...

Exterior Care:

For a long lasting finish, clean and wax the exterior surface. We recommend washing with a mild soap solution. DO NOT use power washing to clean your shed. Using a spray automotive type wax periodically on the exterior is highly recommended if you are in a high humidity or coastal climate region.

Combustibles and corrosives must be stored in air tight containers designed for chemical and/or combustible storage. Corrosive chemicals such as fertilizers, pesticides and herbicides should be cleaned off the interior and exterior surfaces immediately. Rust caused by chemical damage is not covered by the warranty.

DO NOT STORE POOL CHEMICALS IN YOUR SHED - THIS VOIDS YOUR WARRANTY

Rust protection precautions may help to stop rust from developing, or stop it quickly as soon as it appears.

- Avoid nicking or scraping the coating surface, inside and out.
- Keep roof, base perimeter and door tracks free of debris and leaves which may accumulate and retain moisture. These can do double damage since they give off acid as they decay.
- Touch up scrapes or nicks and any area of visible rust as soon as possible. Make sure the surface is free of moisture, oils, dirt or grime and then apply an even film of high quality touch-up paint.
- Various paint manufacturers provide products for rust treatment and coverage. If surface rust does appear on your shed we recommend treating those areas as soon as possible, following the paint supplier of your choice instructions.
- Our customer service department can provide the paint tinting formula for matching the color of your shed. We also have touch-up paint available for repairing small nicks and scratches.

Roof:

Keep the roof clear of leaves and snow. Heavy amounts of snow on the roof can damage the building making it unsafe to enter. In snow country, Roof Strengthening Kits are available for most Arrow Buildings for added protection against heavy snow accumulation.

Doors:

For sliding doors, always keep door tracks clear of dirt and other debris that prevents them from sliding easily. Lubricate door track annually with furniture polish or silicone spray. Keep doors closed and locked to prevent wind damage.

Fasteners:

Use all washers supplied to protect against weather infiltration and to protect the metal from being scratched by the screws. Regularly check screws, bolts, nuts, etc., and retighten as necessary.

General:

- A plastic sheet (vapor barrier) placed under the entire floor area may reduce condensation.
- Wash off inked part numbers on coated panels with soap and water.
- Silicone caulking may be used for watertight seals throughout the building.

Please note, Manufacturer cannot be held responsible for any consequences due to buildings that are not installed per these instructions, or for damage due to weather conditions or acts of God.

Keep these assembly instructions and owner's manual for future reference.

ARROW ACCESSORIES...

ANCHOR KITS

Model No. AK4

Anchor Kit contains heavy-duty steel augers, 60' (18 m) of steel cable and 4 cable clamps. No digging or concrete pouring, just insert cable under roof, over roof beams, into augers and twist augers into the ground. For buildings larger than 10'x9' (3,0 m x 2,6 m), use 2 kits.

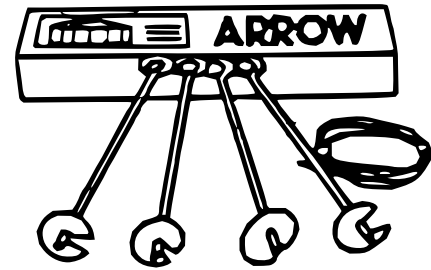

TOOL HANGING RACK

Model No. TH100

The perfect tool organizer. Twin 25 1/2" (64,8 cm) steel channels plus five heavy-duty snap-in hangers and a small tool holder for screwdrivers, pliers, etc. Holders slide along channel for fully adjustable spacing. Great for garage, basement, or the back of any door. Fits all Arrow storage buildings.

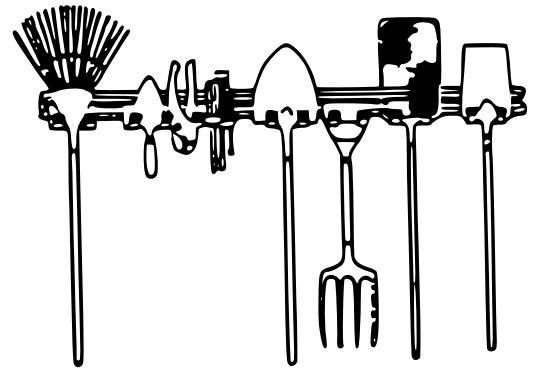

SHELF UNITS

Heavy-duty, galvanized steel shelf units help organize storage space. They easily mount on the wall or sit on the floor. Fits all Arrow buildings.*

Model No. SS404

- Makes 8" to 12" (20,3-30,5 cm) wide shelves in any length.
- Brackets, braces, hardware included.
- Lumber is not included.

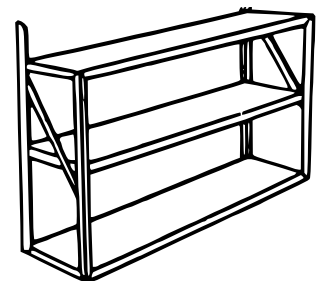
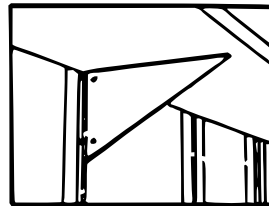
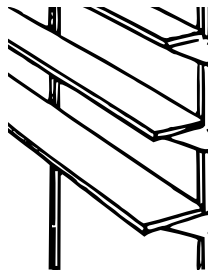

Model No. SS900-A

- Grey color
- 3 shelves
- Holds up to 85 lbs. (38 kg) (even weight distribution)

* Some drilling required to fit buildings without mid-wall bracing.

SPECIAL NOTICE ON DELIVERY:

If your accessory is shipped via truck line a day time phone number is required to arrange delivery. If no one is available to sign for the delivery, you may be subject to a re-delivery charge assessed by the carrier.

HOW TO ORDER

We recommend that you purchase accessory items from your local storage building dealer whenever possible; however, because the full line of accessories is not always available from all dealers, Arrow is offering them to you on a direct basis.

Purchase Online at www.arrowsheds.com

Purchase over the phone by calling 1-800-851-1085

Most major credit cards accepted. Allow 2 weeks for Delivery.

ASSEMBLY NOTES

