

718790814

Owner's Manual & Assembly Guide



INNOVATION UNDER COVER®

www.arrowsheds.com

Model No. DS108

10' x 8'

Nominal Size

! caution
sharp edges *

Gloves must be worn at all times to reduce risk of injury!

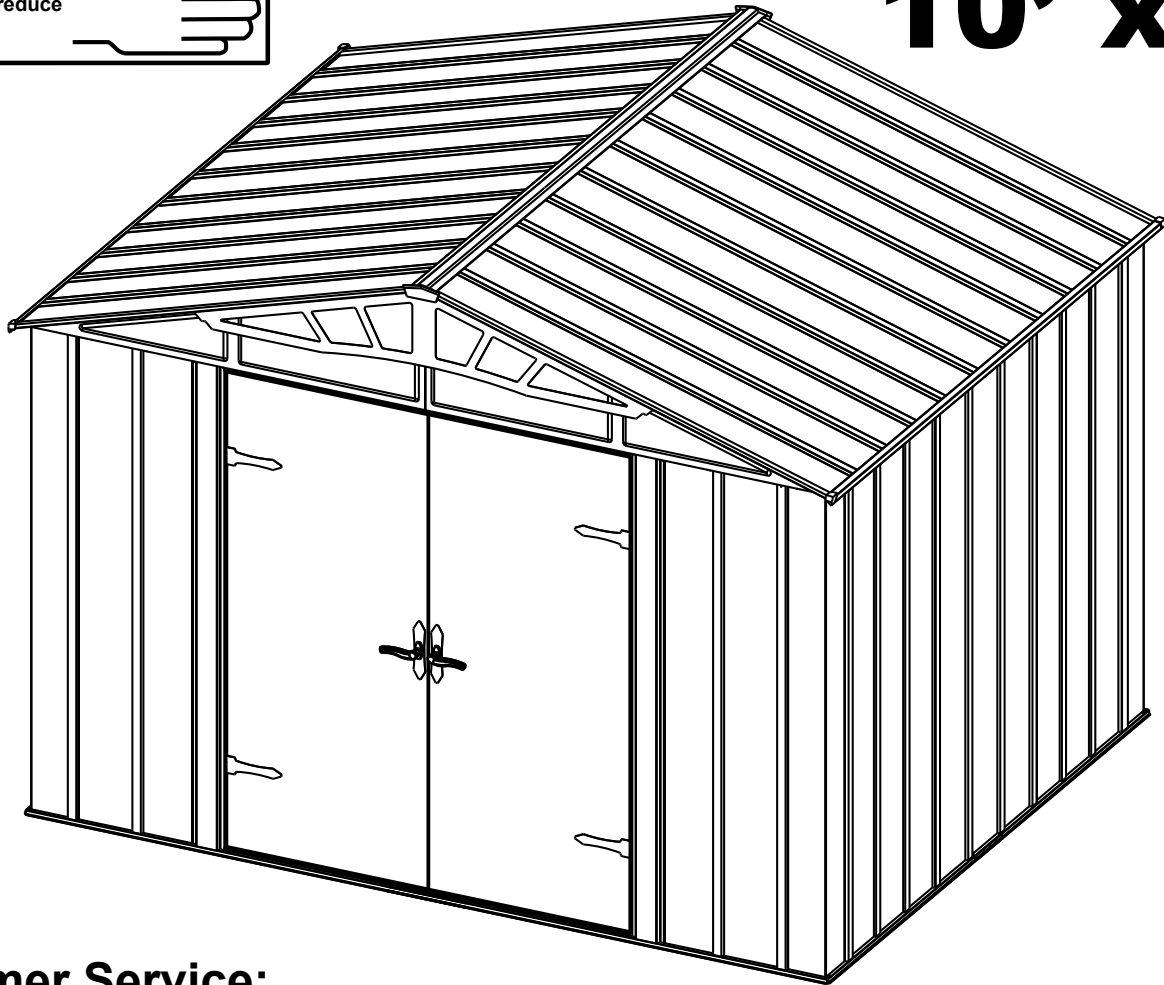

Customer Service:
1-800-851-1085 or
assist@arrowsheds.com

Base Size	121" x 97" 307,3 cm x 246,4 cm
------------------	-----------------------------------

BUILDING DIMENSIONS

†Size rounded off to the nearest foot

For proper base construction see page 12

Approx.† Size	Storage Area	Exterior Dimensions (Roof Edge to Roof Edge)			Interior Dimensions (Wall to Wall)			Door Opening	
		Width	Depth	Height	Width	Depth	Height	Width	Height
10' x 8'	77 Sq. Ft. 520 Cu. Ft.	123 1/4"	99 1/2"	90 3/4"	118 1/4"	94 1/4"	89 1/4"	59 1/2"	69 1/4"
3,0 m x 2,4 m	7,2 m ² 14,7 m ³	313,1 cm	252,7 cm	230,5 cm	300,4 cm	239,4 cm	226,7 cm	151,1 cm	175,9 cm

* See Inside for Detailed Safety Information.

SAFETY PRECAUTIONS...

Safety precautions MUST be followed at all times throughout the construction of your building!

sharp edges

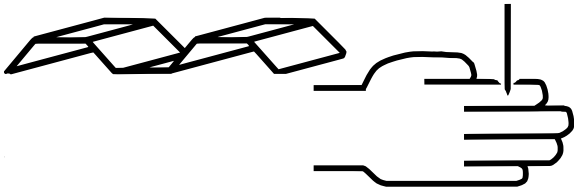

Care must be taken when handling various pieces of your building since many contain sharp edges. Please wear work gloves, eye protection and long sleeves when assembling or performing any maintenance on your building.

always practice proper tool safety

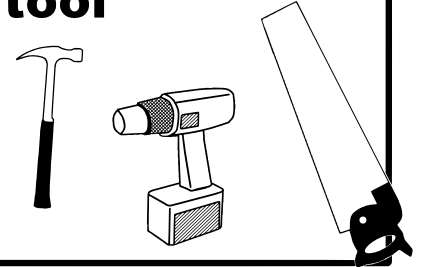

Practice caution with the tools being used in the assembly of this building. Be especially familiar with the operation of all power tools.

no children or pets at worksite



Keep children and pets away from the worksite during construction and until the building is completely assembled. This will help avoid distractions and any accidents which may occur.

don't focus weight on roof

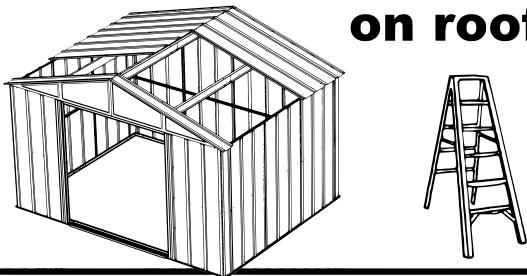

NEVER concentrate your weight on the roof of the building. When using a step ladder make sure that it is fully open and on even ground before climbing on it.

beware of wind



Do NOT attempt to assemble your building on a windy day. The large panels can catch the wind like a "sail", causing them to be whipped around making construction difficult and unsafe.

Do NOT attempt to assemble your building before double checking that you have all the parts indicated on the parts list (page 8) as well as all hardware (page 7). Any building left partially assembled may be seriously damaged by even light winds.

IMPORTANT NOTE ON ANCHORING

- Your building MUST be anchored to prevent wind damage. An anchoring kit is not supplied with your building and you have many options when it comes to anchoring. See anchoring page for more info.
- You must also have a temporary anchoring system in place in case you need to take a break from assembly. See page 4 for more info.

ASSEMBLY TIPS & TOOLS

Watch the Weather Closely: Be sure the day you choose to install your building is dry and calm. Do **NOT** attempt to assemble your building on a windy day. Be careful on wet or muddy ground.

Use Teamwork: Two or more people are required to assemble your building. One person can hold the parts or panels in place while the other person fastens them together and handles the tools. This makes the process of assembling your building faster and safer.

Tools and Materials: Here is a list of some basic tools and materials you will need to assemble your building. Decide which method of anchoring and the type of base you will use to make a complete list of the materials you will need.

WHAT YOU NEED

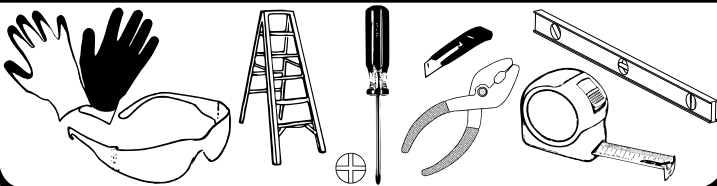

- Work Gloves
- Safety Glasses
- Step Ladder
- No. 2 Phillips Screwdriver (Magnetic Tip Preferred)
- Utility Knife or Scissors
- Pliers
- Carpenter's Level
- Tape Measure

RECOMMENDED TIME SAVERS

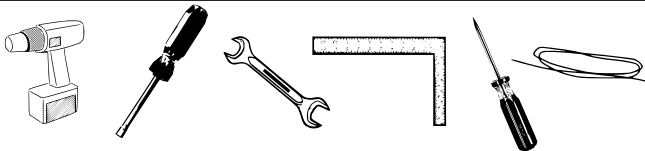

- Power Drill (Cordless, Variable Speed)
- Nut Driver or Wrench
- Square
- String (for squaring the frame)
- Awl (to align holes)

BASE PREPARATION TOOLS

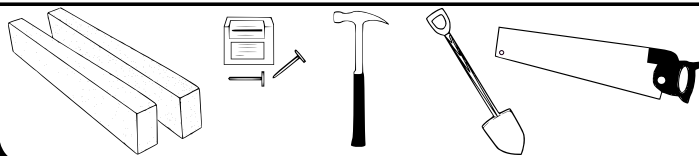

- Lumber and/or Concrete
- Hammer and Nails
- Spade or Shovel
- Hand Saw or Power Saw

How to Select and Prepare Your Building Site: Before you start to assemble your building, you will want to decide on a good location. The best location is a level area with good drainage.

- Allow enough working space so it is not difficult to move parts into position for assembly. Be sure there will be enough space at the entrance for the doors to completely open. Also, there needs to be enough space outside the building to be able to fasten the panel screws from the outside.
- Before assembling any parts, your base should be constructed and an anchoring system should be ready to use.

FREQUENTLY ASKED QUESTIONS

Q. How long will it take to assemble the building?

A. Assembly time depends on a variety of factors, including roof design, tools available, DIY skill and the pace at which you work. Guidelines for each shed assembly are approximate AFTER completion of the base, and assume two or more people working on the assembly. Generally, you should plan on at least one day working with someone who can assist you; again, after constructing the base. Refer to the clock icons on each product page on the website for specific time estimates.

Q. How do I decide where to put my shed?

A. The key to a successful assembly is to make sure the shed will be square and level when built. The shed can be assembled directly onto level ground (grass or dirt). If you have location options, choose one that is already flat, with good drainage to control moisture. If you don't have a flat, well-drained area, you need to prepare the space. Level the area using cinder blocks, concrete, crushed gravel or other sturdy materials. Once level with good drainage, construct your base. Using a carpenter's level, make sure your base is level and free of bumps or ridges to provide good support for your building.

Q. What if I can't finish my building in one session?

A. If weather conditions change so that it becomes windy or rainy, it is recommended that you stop assembly until conditions improve. This is for your safety and for protection of the shed panels. However, do not leave your unfinished construction without first temporarily anchoring the corners of the shed to your base and placing weights, such as patio blocks or sandbags, on the floor frame. Failure to anchor the building if you leave it while partially assembled could result in irreparable damage or personal injury if the building collapses.

Note: Most instruction manuals provide a warning note at the beginning of the installation step for corner panels, stating that the remainder of the building assembly requires multiple hours and more than one person. Do not continue beyond this point if you do not have enough time or help to complete the assembly that day. A partially assembled building can be severely damaged by even light winds.

Q. Do I need to anchor my building?

A. Yes! Fully assembled buildings should be anchored using a permanent anchoring system. If you need to leave your building before it is completely assembled, you will need to temporarily anchor the corners of the shed to your base, and place weights, such as patio blocks or sandbags, on top of the floor frame.

Q. How do I temporarily anchor my building before it's fully assembled?

A. An incomplete building must be anchored before breaking for any period of time to prevent possible damage.

- If the building is on a wood base, secure the frame with wood screws in the corners
- If the building is on a concrete base, temporarily anchor the frame in the corners
- Use patio blocks or sandbags on top of the floor frame as weights
- Secure the floor frame to the ground with ground augers or rope the frame in the corners to the ground

Q. How do I control condensation and prevent water from leaking in?

A. To minimize condensation, install a continuous, unbroken plastic vapor barrier with a thickness of 6 mil. between exposed ground surface and the building's base. Make sure that all weather stripping and washers are used throughout the assembly process. Make sure that the weather-stripping tape adheres to the panels when installing it along the main ridge beam. Do not stretch it. Apply it directly off the roll onto clean panels. Ensure that all washers are flush with the panels and do not over-tighten screws, as this can crack the washers. Silicone caulking may be used to create watertight seals at the washers and throughout the building.

Q. What kind of base do I use?

A. You can:

- Use an Arrow Base Kit
- Pour a concrete slab
- Build a wood deck/floor (use exterior-grade plywood)
- Use patio blocks
- Build on crushed gravel, dirt or grass

Arrow provides a base kit accessory that is an option for most building sizes. If you are building a wood deck/floor, an Arrow floor frame kit on top of your deck/floor assembles in minutes and provides a floor frame suitable for a 5/8" exterior-grade plywood floor (not included). A continuous unbroken plastic vapor barrier with a thickness of 6 mil. between the ground and the building's base is also recommended.

Q. How should I measure for my base?

A. Shed dimensions are provided in "nominal" size. Nominal sizes are roof-edge measurements rounded to the nearest foot and are not the measurements to use for constructing the shed base. So, carefully check the exact, recommended base size in the specifications for your shed model.

Q. How do I align the holes in the wall panels with the holes in the floor frame?

A. Make sure that the shed is level and square, with the correct floor frame size, and that the corner panels are installed correctly. Line up the large hole in the panel with the small holes in the floor frame. An awl can be used to help align the holes.

Q. How do I align the holes in the roof panels with the holes in the roof beam and side wall angles?

A. Your building must be level and square in order for the holes to align. It must be square at both the top and bottom. Check that the building is square by measuring diagonally. The two diagonal measurements will be equal. If your building is out of square, carefully rock and push the shed until it is square. Also, try loosening the roof beams to give more play and flexibility. Non-alignment can also occur if your building is not level. You can raise corners and shim under them to make it level. Check that the panels are installed in the proper location. The building should not be permanently anchored until the complete unit is assembled; otherwise, you will not be able to make adjustments for squareness during assembly. Do not attach the bottom of the roof panels to the side wall angles until all the roof panels are up.

Note: If you have to stop assembly for any reason before it is complete, do not leave your unfinished construction without first temporarily anchoring the corners of the shed to your base and placing weights, such as patio blocks or sandbags, on the floor frame.

Q. How do I ensure that the sliding doors on the building will hang level?

A. Make sure that the door track has been correctly installed, with the long leg on top and the short leg on the bottom. Check that the door slides are straddling the upper and lower legs of the door track assembly, putting the door slide only halfway in the track. Also, the rounded end of the door slide should be at the bottom and the square end at the top.

Q. What kind of customer support is available?

A. Our instruction manuals contain step-by-step assembly illustrations and guide you from preparation through assembly to care and maintenance of your finished building. Each part is marked with a factory number for easy identification. In addition, our assembly animation (located under the Customer Support menu on the website) provides helpful tips. But if you need to reach someone at Arrow, you can contact Arrow Customer Service, toll free, at 1-800-851-1085 (press 1) or via e-mail at assist@arrowsheds.com. Have your model number and instruction manual with you when you call.

Q. What if the rear wall angle and channels are too large to fit inside of the rear wall panels?

A. Check the dimensions of wall assemblies. They should be slightly smaller than the floor frames. Lay the assemblies on top of the rear floor frame and pull them up to the top of the wall panels causing the corner panels to stand erect and not lean inward. Caution: Be careful to not scratch the panels on the way up.

Q. The wide rib always overlaps the crimped rib. Is there ever an exception?

A. This sequence is to be followed through the assembly process. However, this will typically happen once on the rear and once on each side wall (vertical wall units only) where there will be either two crimped ribs overlapping or two wide ribs overlapping. This may give it a tighter fit, but it will work.

Q. Can the building be painted?

A. The buildings can be painted with an exterior-grade paint designed for use on steel. Contact your local paint supplier for recommendations.

Q. I heard that rust might be an issue with steel; is it?

A. While steel can rust, with proper care this should not be an issue. For a long-lasting finish, periodically clean the exterior surface and apply spray-on car wax. Touch up scratches as soon as you notice them by immediately cleaning the area with a wire brush or emery paper, washing it and applying touch-up paint. This will minimize rust and maintain your shed's attractive appearance for years.

Q. How do I take care of dents in my shed?

A. Proper selection of shed size, including a sufficient door-opening width, and proper placement of your shed should minimize the possibility of damage. If a dent does occur, carefully push the dent out from the opposite side. If the paint has been scratched or removed, touch up the area as soon as you notice it. Immediately clean the area with a wire brush or emery paper, wash it and apply touch-up paint. This will minimize rust and maintain your shed's attractive appearance for years.

Still have questions? Visit us online at www.arrowsheds.com to view lots of helpful tips and information regarding all of our available products. You can also contact our Customer Service team at 1-800-851-1085 (press 1), or via e-mail at assist@arrowsheds.com.

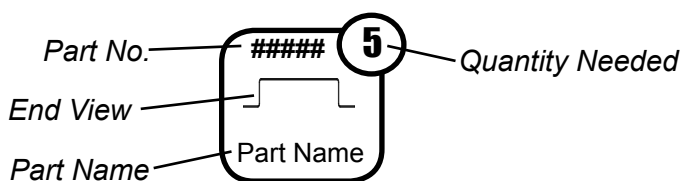

At the top of each page you will see one or more **Part Cues** like the one to the left. These **Part Cues** are designed to help you quickly identify the parts needed for each step.

Confirm that all hardware and parts are present before attempting to assemble your building.

For missing or damaged parts contact Customer Service. Do not return to store.

Customer Service:

1-800-851-1085 or
assist@arrowsheds.com

Part Numbers

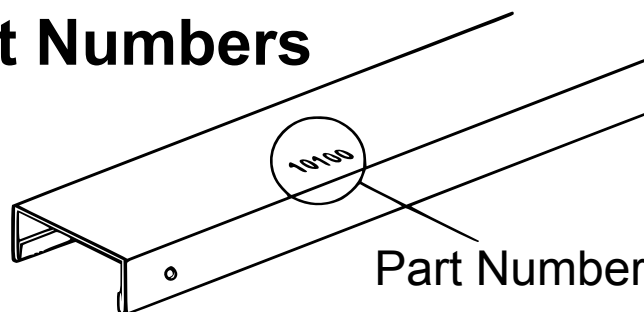

1. Each part has an identifying part number on it.
2. Part Numbers are referenced in each step.
3. Unpainted parts have a stamped in number and painted parts have a number that is inked on.

Remove inked on numbers with soap and water after assembly.

HARDWARE LIST...

Key No.	Part No.	Part Description	Qty.	✓ List
1	65103	Hex Nut (#8-32)	182	
2	65923-33	Small Bolt (Sand) (#8-32 x 3/8) (10 mm)	108	
3	65923-18	Small Bolt (Java) (#8-32 x 3/8) (10 mm)	50	
4	65004-33	Small Screw (Sand) (#8AB x 5/16) (8 mm)	224	
5	65004-18	Small Screw (Java) (#8AB x 5/16) (8 mm)	148	
6	66783	Flat Head Bolt (#8-32 X 1/2) (13 mm)	24	
7	65958	Long Bolt (#8-32 x 7/8) (22 mm)	4	
8	66692	Tapping Screw (#10ABx1) (25 mm)	2	
9	66810	Left Handle	1	
10	66809	Locking Handle Right	1	
11	66054	Latch	1	
12	66609	Hinge	4	
13	66183L	Left Roof Trim Cap	2	
14	66183R	Right Roof Trim Cap	2	
15	67545	Weather Stripping	1	
16	67468	Peak Cap	2	
17	67236	Adhesive Pads (2 per sheet)	1	
18	66684	Top Latch Spring	1	
19	66808	Bottom Latch Spring	1	
20	66646	Washer Sheet	10	
21	66811	Handle Backplate	2	
22	66812	Hinge Plate Decoration	4	
23	6228	Track Support	2	

Hardware Views by Key No.

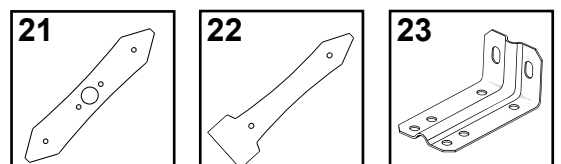
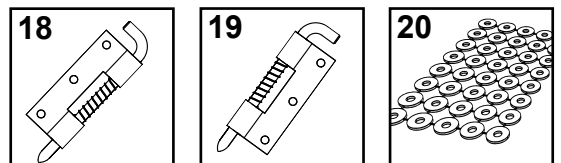
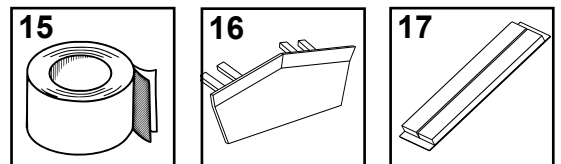
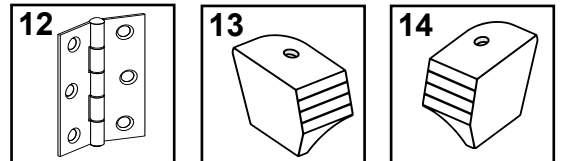
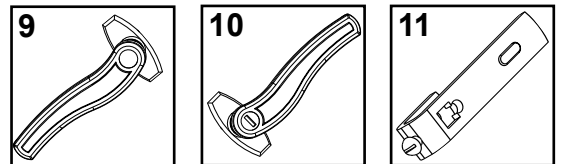
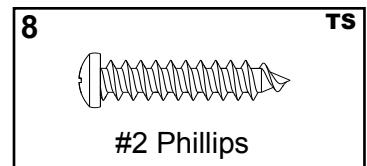
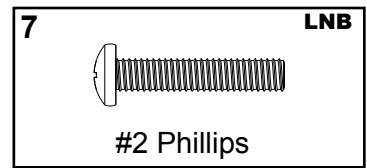
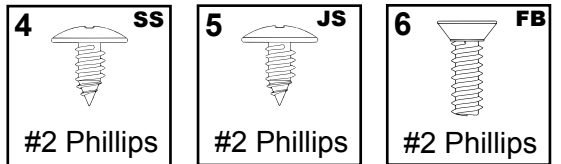
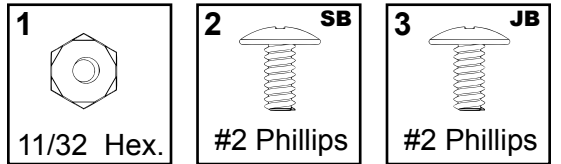

Various fasteners are used throughout the construction of your storage unit. In each step you will see the abbreviations listed below used in the illustrations to help you identify which fastener to use.

The fasteners used in each step are shown actual size at the top of each page. If you are unsure which fastener to use, hold it up to the picture and use the one that matches.

- SB** - Sand Bolt
- JB** - Java Bolt
- SS** - Sand Screw
- JS** - Java Screw
- FB** - Flat Head Bolt
- TS** - Tapping Screw
- LNB** - Long Bolt

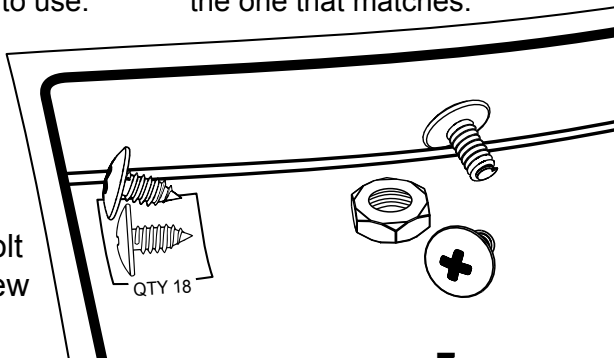

PARTS LIST...

Key No.	Part No.	Part Description	Qty.	<input checked="" type="checkbox"/> List
1	6635	Roof Beam Bracket	4	
2	9009	Gable Brace	2	
3	9204	Roof Beam Brace	2	
4	5210	Wall Panel	8	
5	6521	Wall Panel	2	
6	7571	Roof Panel	4	
7	7743	Roof Panel	2	
8	8576	Right Gable	2	
9	8577	Left Gable	2	
10	10699	Front Wall Panel	2	
11	10700	Right Roof Panel	2	
12	10701	Corner Panel	4	
13	10702	Ramp	1	
14	10703	Front/Rear Floor Frame	4	
15	10704	Side Floor Frame	4	
16	5986	Rear Wall Angle	2	
17	10706	Side Wall Angle	4	
18	10707	Inner Front Header	1	
19	10708	Outer Front Header	2	
20	10709	Front Wall Channel	2	
21	10710	Right Side Roof Trim	2	
22	10711	Ridge Cap	1	
23	10712	Ridge Cap	1	
24	10713	Roof Beam	8	
25	9917	Rear Wall Channel	2	
26	10715	Side Wall Channel	4	
27	10716	Right Door Jamb	1	
28	10782	Door	2	
29	10718	Horizontal Door Brace	4	
30	10719	Door Handle Brace	2	
31	10720	Diagonal Door Brace	8	
32	10721	Door Stop	1	
33	80053	Left Roof Panel	2	
34	80055	Left Side Roof Trim	2	
35	80057	Left Door Jamb	1	
36	69835	Gable Trim (Green)	4	
37	66818	Gable Decor	1	

Selected End Views by Key No.

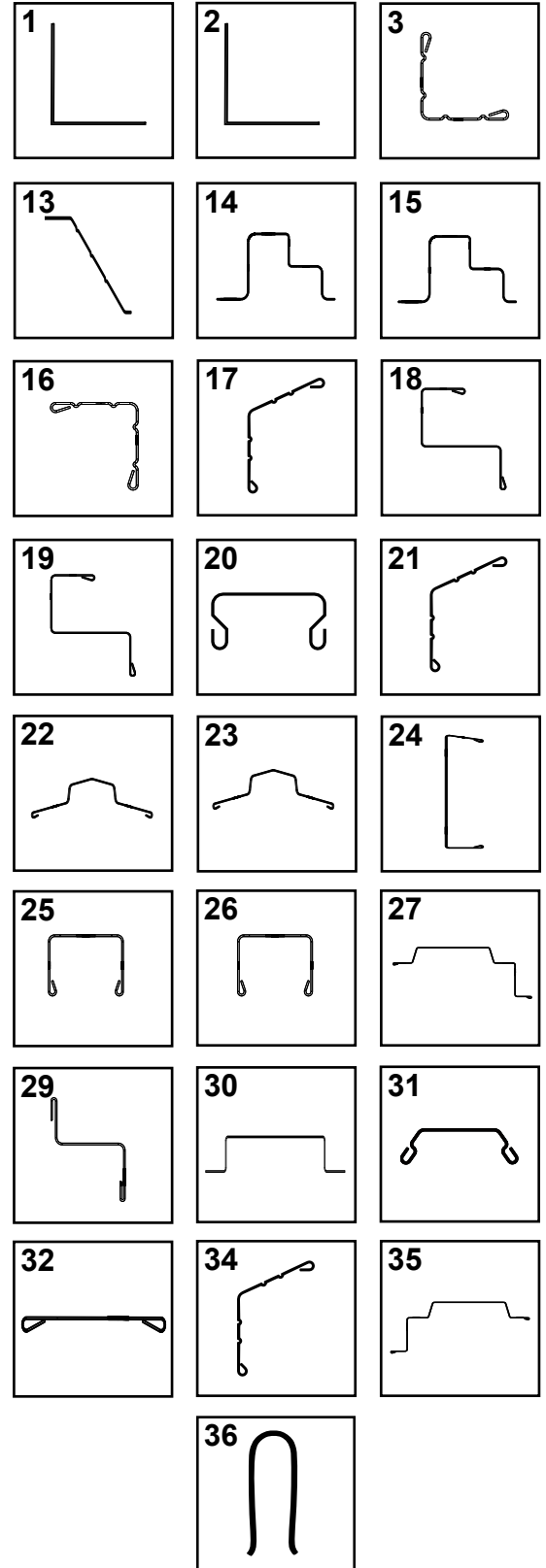

ASSEMBLY BY KEY NO.

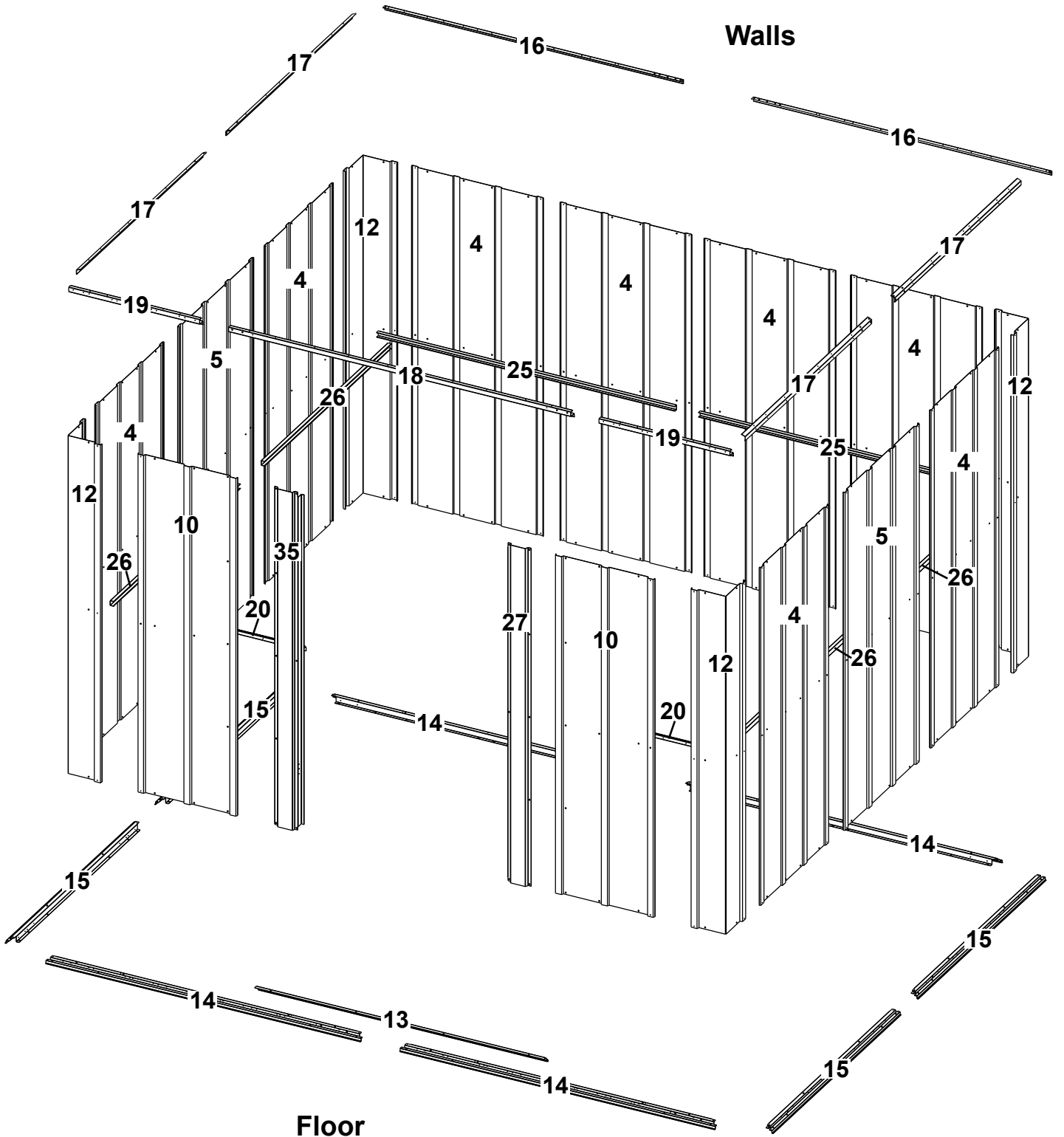

ASSEMBLY BY KEY NO.

Roof

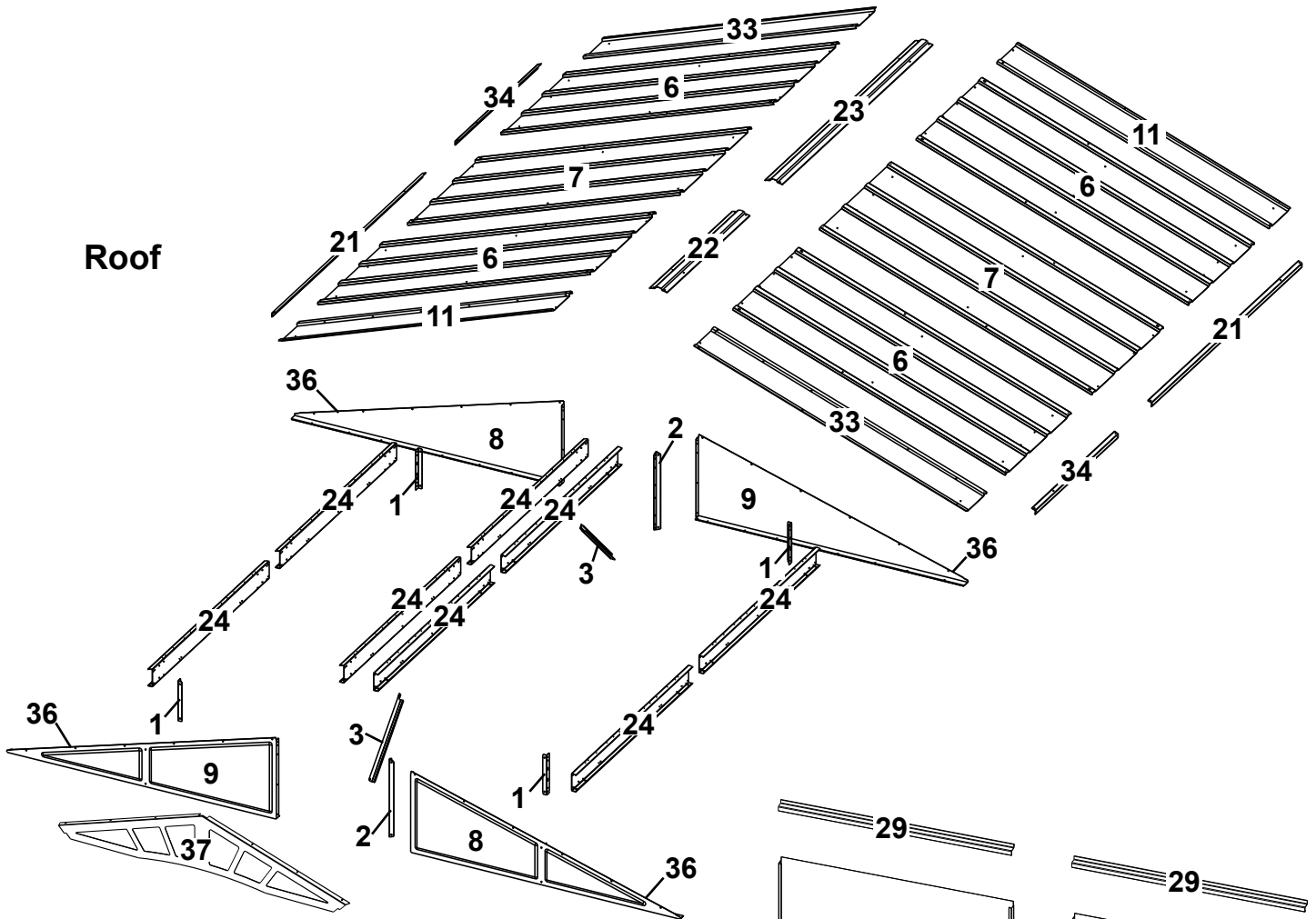

Doors

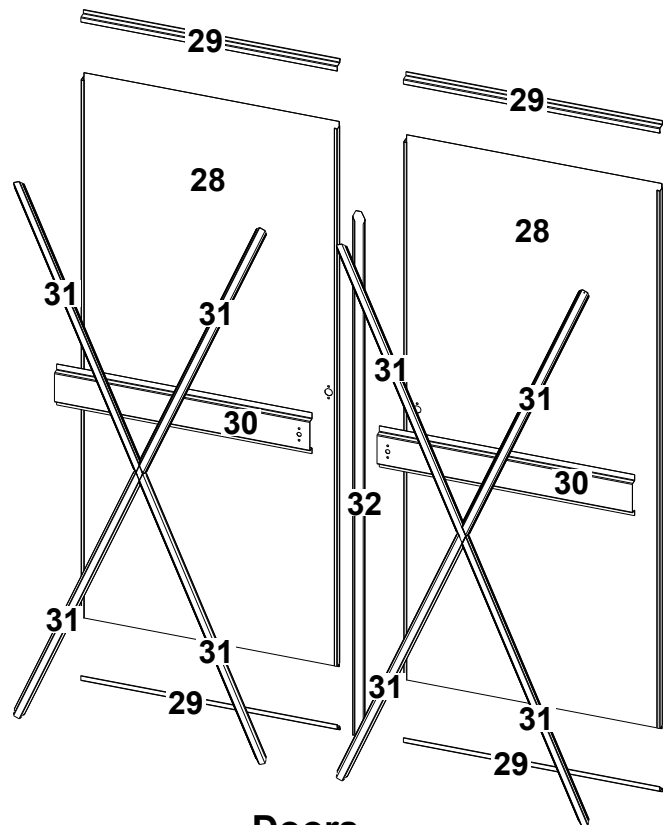

ASSEMBLY OVERVIEW

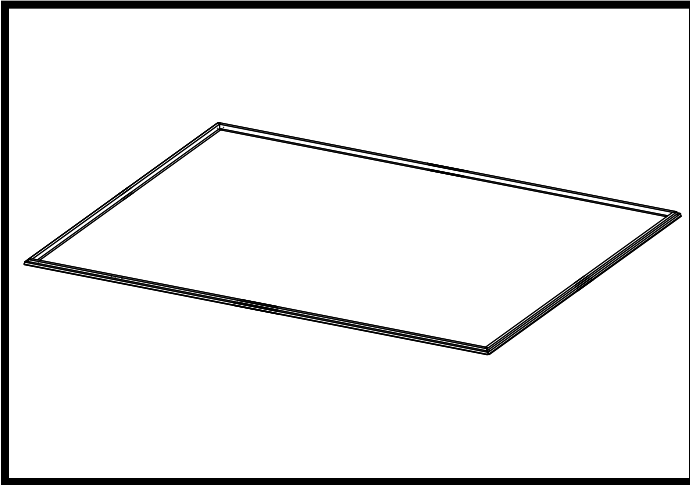

Build the Floor Frame

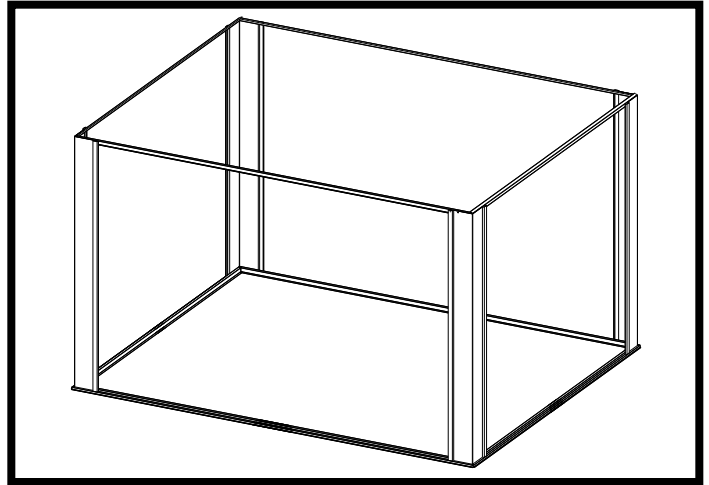

Install Corner Panels, Side Angles, Rear Angles, and Front Header

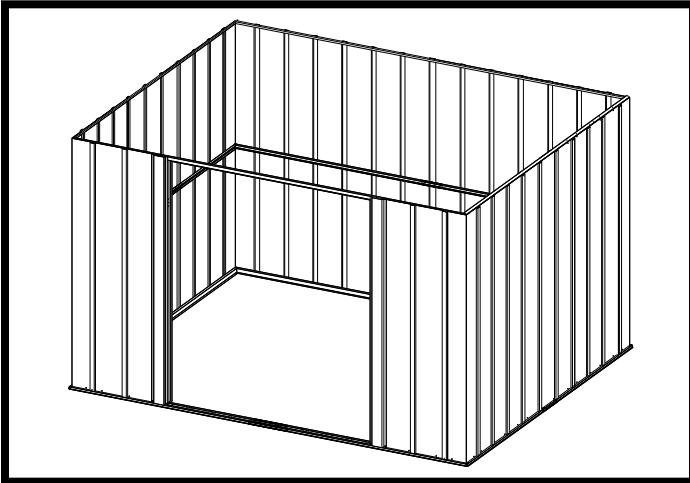

Install Wall Panels, Wall Channels, and Door Jambs

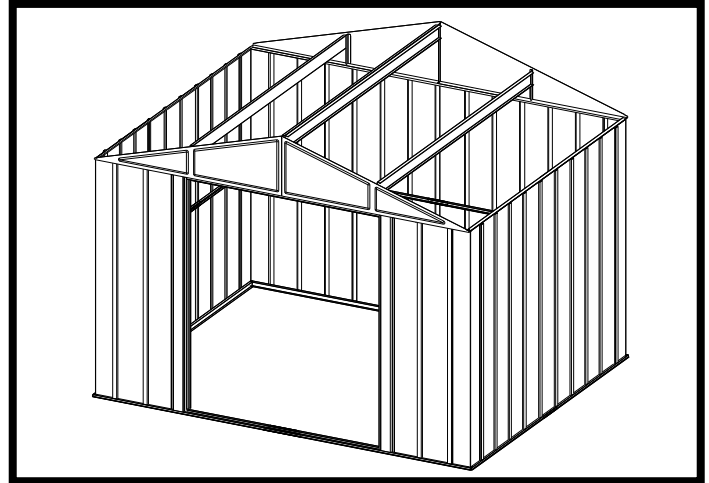

Attach Gables and Roof Beams

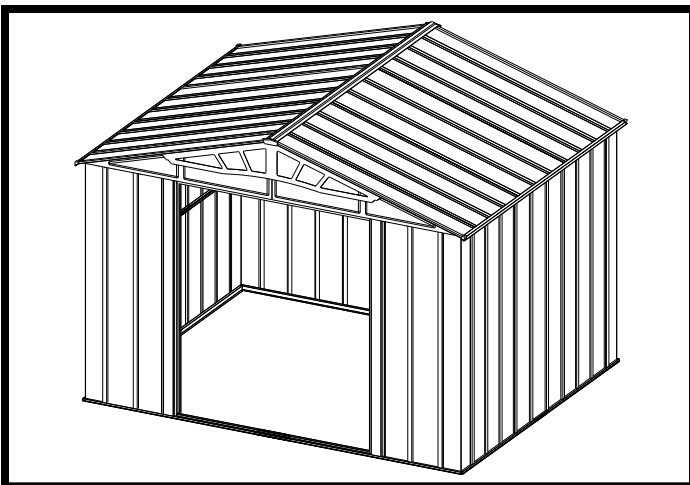

Install Roof Panel, Decorative Gable Piece, Ridge Cap, Side Trim, and Corner Cap

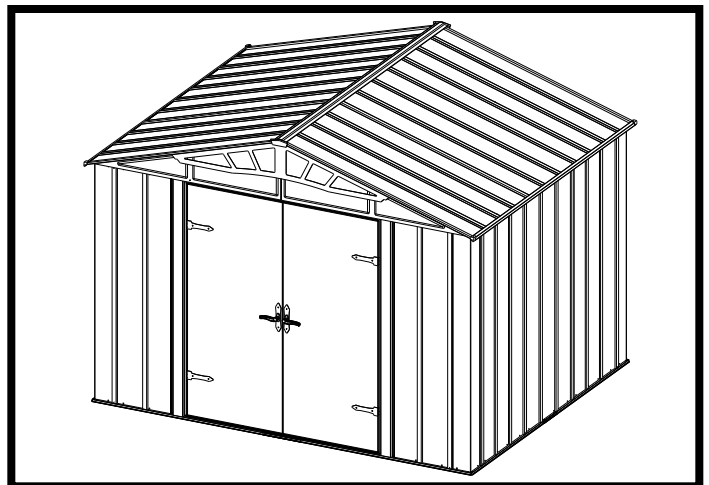

Install Doors

Shed is now complete.

CONSTRUCTING A BASE...

No matter which of the options below you choose for a base, an ARROW ANCHORING KIT is recommended as an effective method of properly securing your building after assembly is complete.

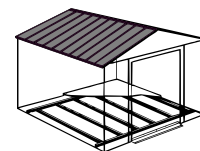

OPTION 1: Directly on ground (earth)

Assemble your building directly on level ground (grass, dirt, rock, sand, etc.). If you choose this option Arrow has a simple kit available to provide a floor **inside** the shed to keep stored items off the ground. This kit can be used to support a plywood floor (wood not included) or be filled with sand/rock to provide a solid surface. (Order No. FBSDS108)

Allow 1 - 2 hours for construction.

OPTION 2: Wood Platform

If you decide to build your own base, be sure to select the appropriate materials.

These are the recommended materials for your base:

- 2 x 4's (38 mm x 89 mm) Pressure Treated Lumber • 5/8" (15,5 mm) 4 x 8 (1220 mm x 2440 mm) Plywood-exterior grade
- 10 & 4 penny Galvanized Nails • Concrete Blocks (optional)

NOTE: Pressure Treated Lumber must not be used where it will make contact with your storage building. The properties of Pressure Treated Lumber will cause accelerated corrosion. **If Pressure Treated Lumber comes in contact with your storage building your warranty will be voided.**

The platform should be level and flat (free of bumps, ridges etc.) to provide good support for the building. The necessary materials may be obtained from your local lumber yard.

To construct the base follow instructions and diagram.

- Construct frame (using 10 penny galvanized nails)
- Measure 16"/24" (40,6 cm/61,0 cm) sections to construct inside frame (see diagram)
- Secure plywood to frame (using 4 penny galvanized nails)

Allow 6 - 7 hours for construction.

OPTION 3: Concrete Slab

The slab should be at least 4" (10,2 cm) thick. It must be level and flat to provide good support for the frame.

The following are the recommended materials for your base.

- 1 x 4's (19 mm x 89 mm) (will be removed once the concrete cures)
- Concrete • Sheet of 6 mil plastic
- We recommend for a proper strength concrete to use a mix of:
1 part cement • 3 parts pea sized gravel • 2 1/2 parts clean sand

Prepare the Site/Construct a Base

1. Dig a square, 6" (15,2 cm) deep into the ground (remove grass).
2. Fill up to 4" (10,2 cm) in the square with gravel and tamp firm.
3. Cover gravel with a sheet of 6 mil plastic.
4. Construct a wood frame using four planks of 1x4 (19 mm x 89 mm) lumber.
5. Pour in concrete to fill in the hole and the frame giving a total of 4" (10,2 cm) thick concrete. Be sure surface is level.

Allow 3 - 5 hours for construction and a week for concrete curing time.

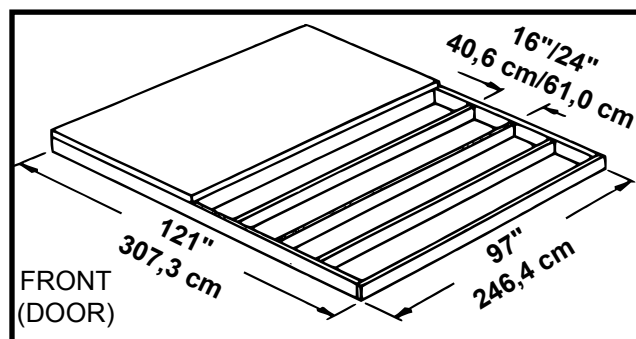

Note: Platform/Slab will extend 9/16" (1,4 cm) beyond floor frame on all four sides. Seal this 9/16" (1,4 cm) of wood with a roofing cement (not included), or bevel this 9/16" (1,4 cm) of concrete when pouring, for good water drainage.

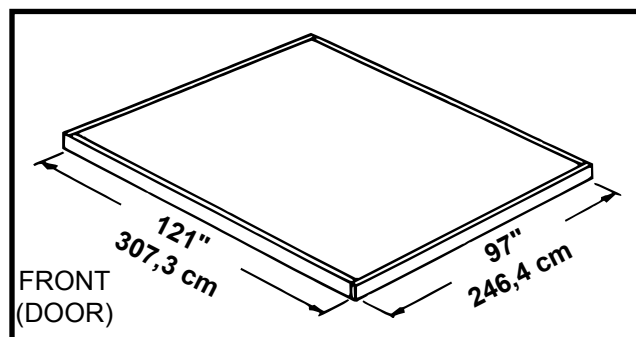

Note: Finished Slab dimensions, with lumber removed.

Step 1: Floor Frames

You will need for this page:

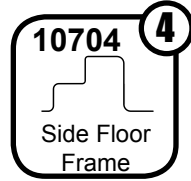
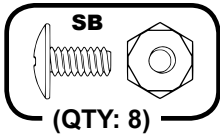

NOTE Washers are to be used on painted parts only. Washers are not necessary on unpainted parts and there are not enough to use on every screw and bolt.

1 Overlap two (2) **Side Floor Frames** as shown and secure with four (4) **Sand Bolts** and **Nuts**. Two (2) **Sand Bolts** and **Nuts** must enter from bottom.

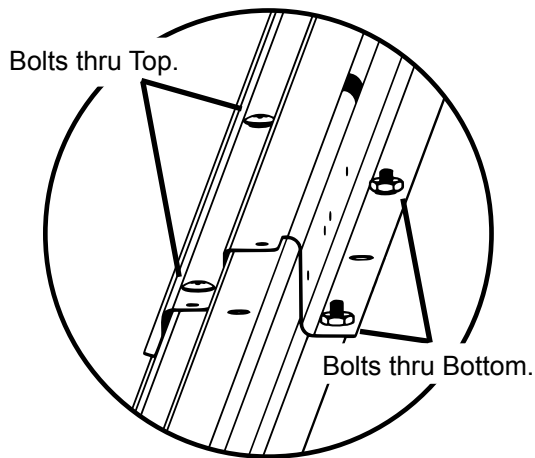
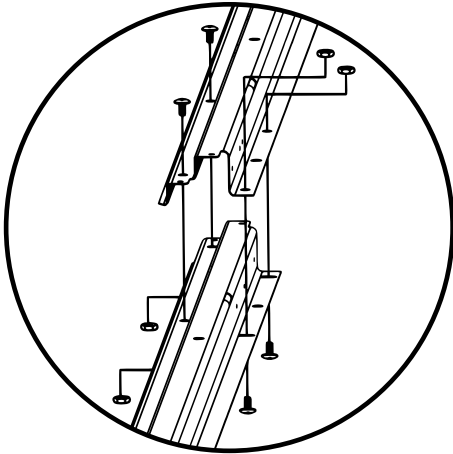

BUILD TWO (2) FRAMES

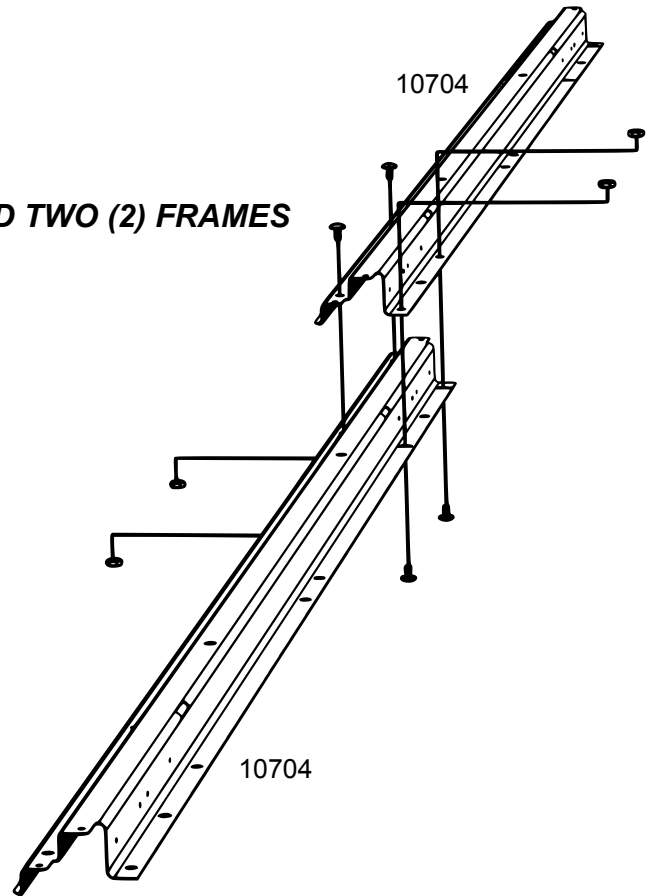

2 Assemble a second **Side Floor Frame Assembly** by repeating Step 1. Check that the finished length of the assemblies is $95 \frac{3}{8}$ " (242,3 cm). Set aside for use in Step 8.

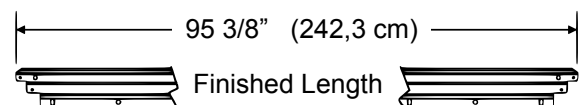
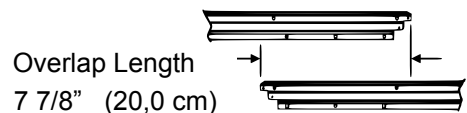

Step 1: Continued

You will need for this page:

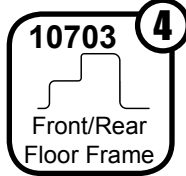
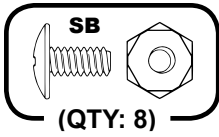

3 Overlap two (2) **Front/Rear Floor Frames** as shown and secure with four (4) **Bolts and Nuts**. Two (2) **Sand Bolts and Nuts** must enter from bottom.

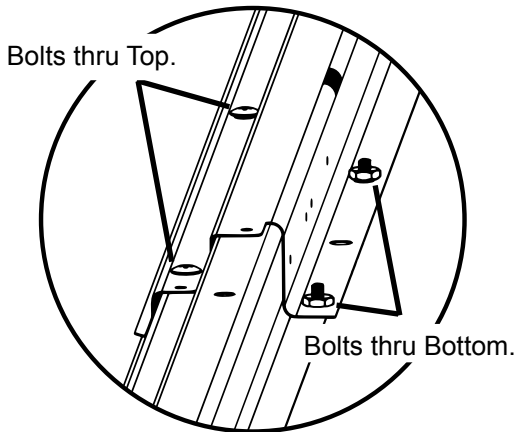
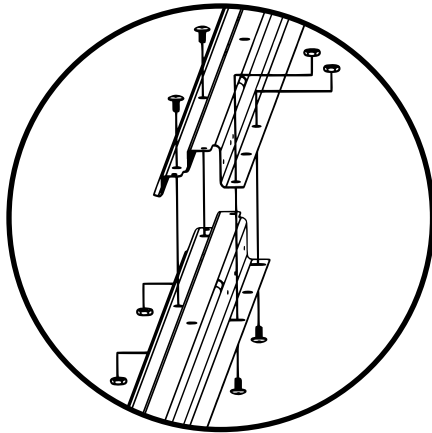

BUILD TWO (2) FRAMES

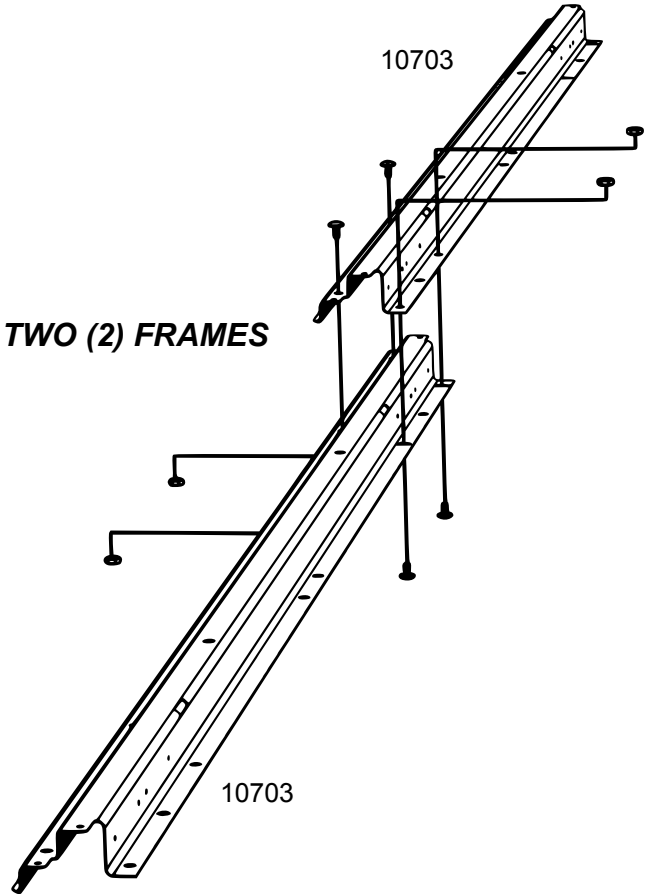

4 Assemble a second **Front/Rear Floor Frame Assembly** by repeating Step 3. Check that the finished length of the assemblies is 119 3/8" (303,2 cm). Set aside for use in Step 8.

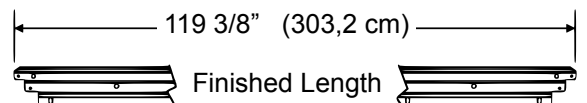
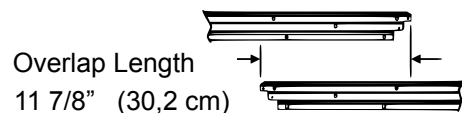

Step 2: Wall Frames

You will need for this page:

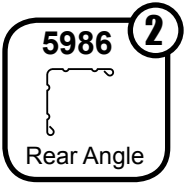
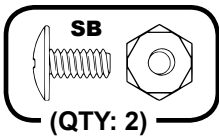

1 Overlap two (2) **Rear Wall Angles** so that five (5) holes align as shown. Insert one (1) **Sand Bolt** and **Nut** through the center hole. Set aside for use in Step 10.

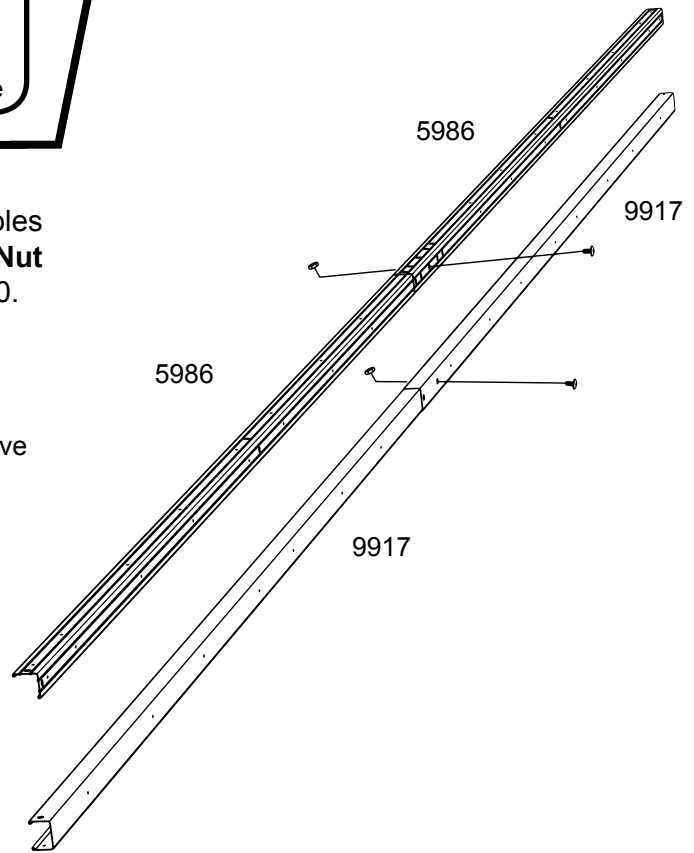
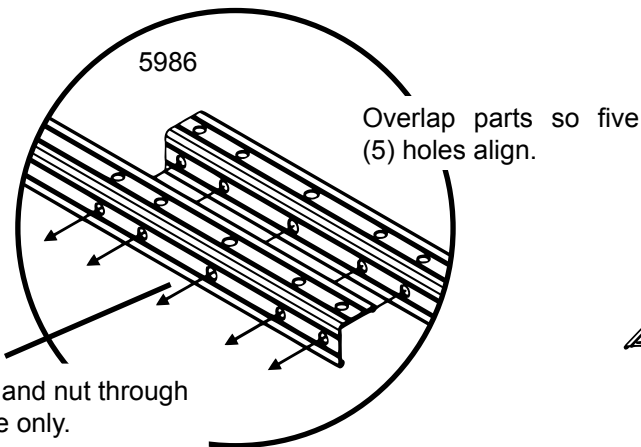

2 Overlap two (2) **Rear Wall Channels** so that three (3) holes align as shown. Insert one (1) **Sand Bolt** and **Nut** through the center hole. Set aside for use in Step 13.

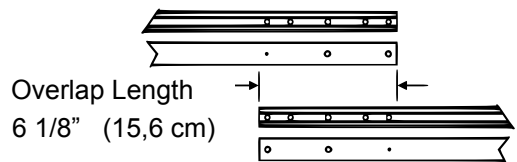
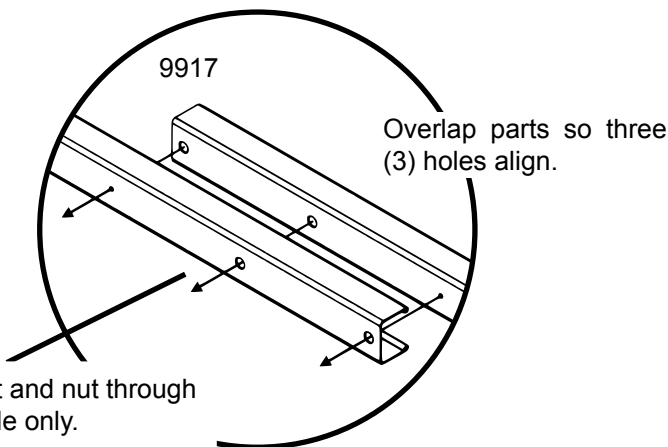

3 Check that the finished length of the assemblies is 118 1/8" (300,0 cm).

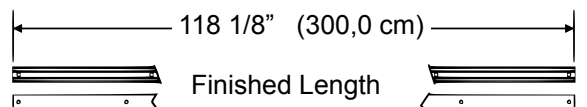

Step 2: Continued

You will need for this page:

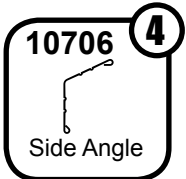
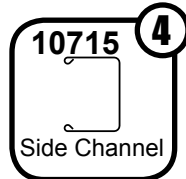
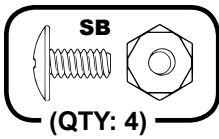

4

Overlap two (2) **Side Wall Angles** so that three (3) holes align as shown. Insert one (1) **Sand Bolt** and **Nut** through the center hole. Set aside for use in Step 10.

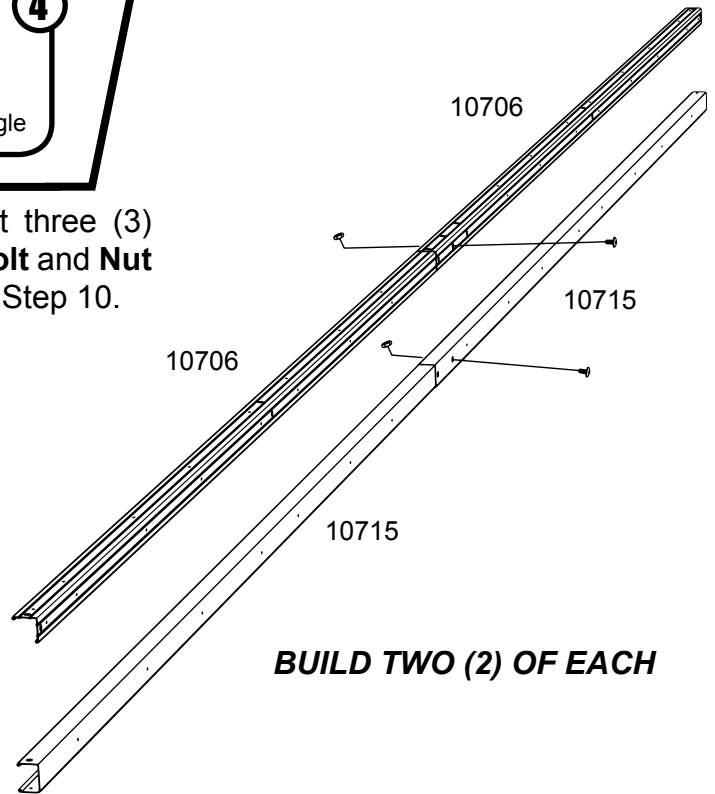
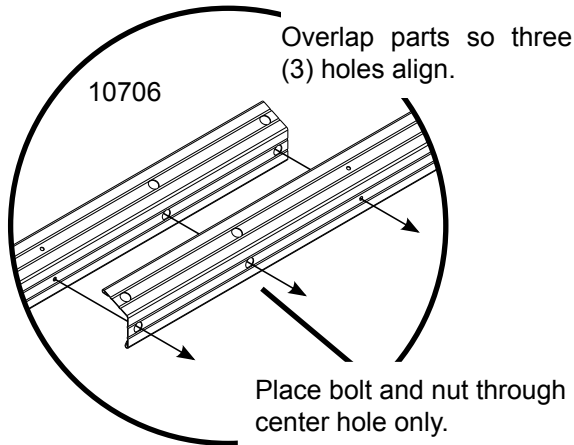

5

Overlap two (2) **Side Wall Channels** so that three (3) holes align as shown. Insert one (1) **Sand Bolt** and **Nut** through the center hole. Set aside for use in Step 13.

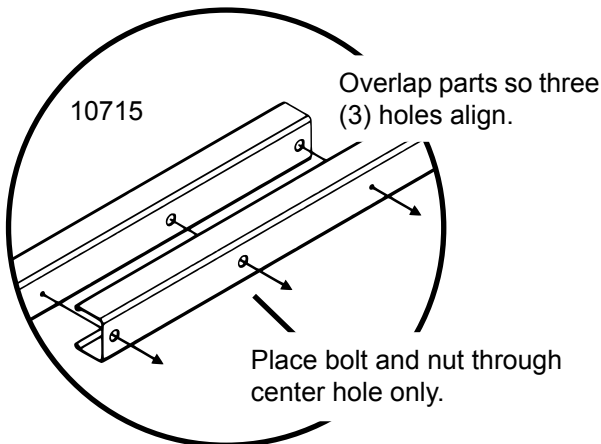

6

Repeat steps 4 & 5 to build a second set of each assembly.

7

Check that the finished length of the assemblies is 94 1/8" (239,1 cm).



CHECK THAT ALL ASSEMBLED PARTS ARE THE CORRECT LENGTH BEFORE CONTINUING

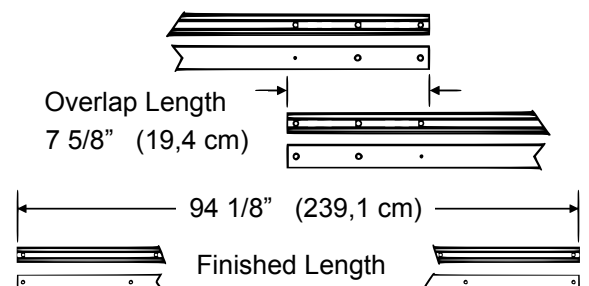

Step 3: Header

You will need for this page:

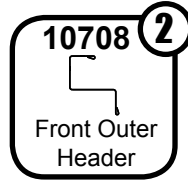
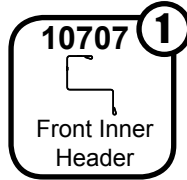
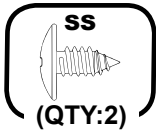

- 1** Connect the **Front Inner Header** to a **Front Outer Header** using one (1) **Sand Screw** as shown. Repeat this for the opposite end. Set aside for use in Step 10.

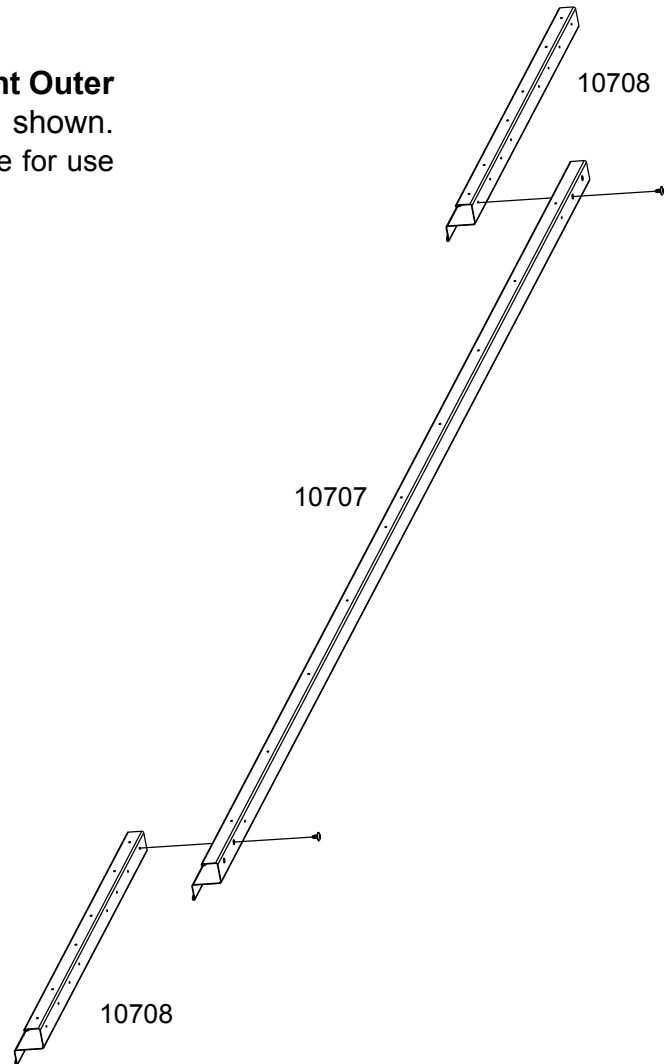
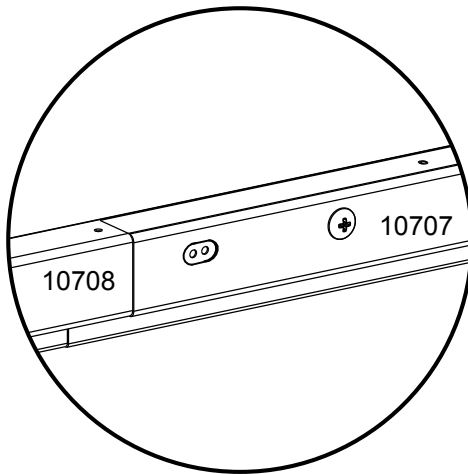
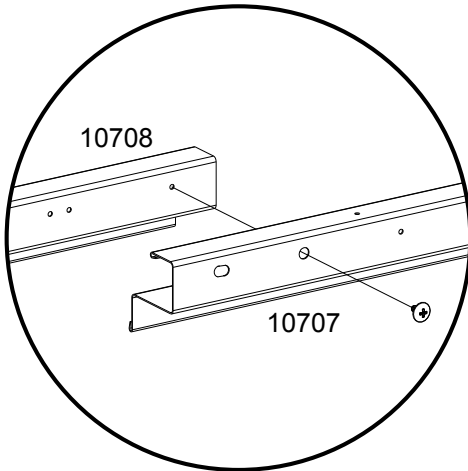

- 2** Check that the finished length of the Assembly is 118 1/8" (300,0 cm).

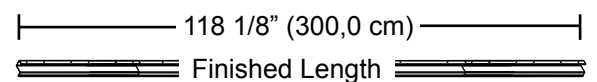
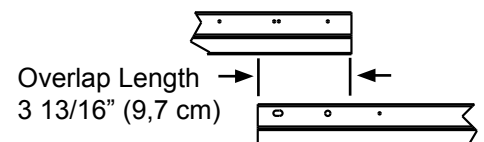

Step 4: Roof Beams

You will need for this page:

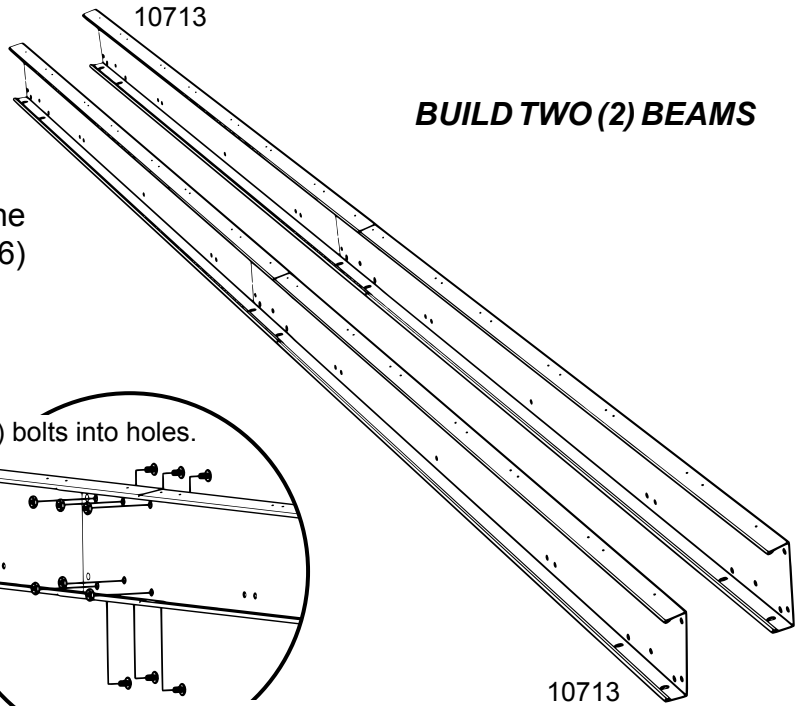
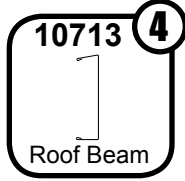
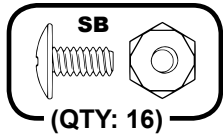

1 Overlap two (2) **Roof Beams** so that the bottom slots align as shown. Insert six (6) **Sand Bolts** and **Nuts** as shown below.

Overlap parts so the bottom slots align.

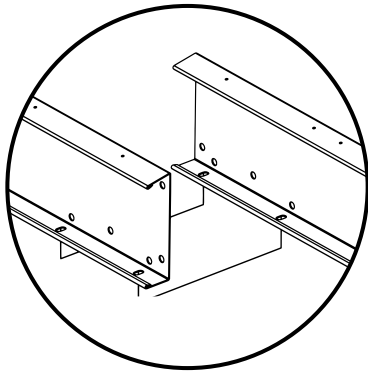

Insert six (6) bolts into holes.

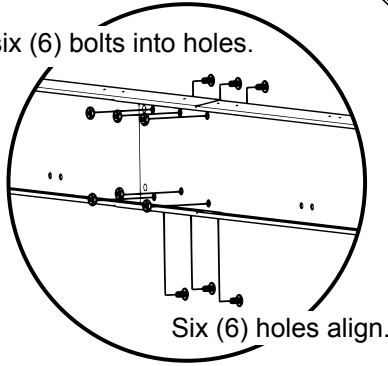

2 Insert two (2) **Sand Bolts** and **Nuts** into slots on bottom of the **Beam** as shown. Set aside for use in Step 15.

Insert bolts into slots from bottom.

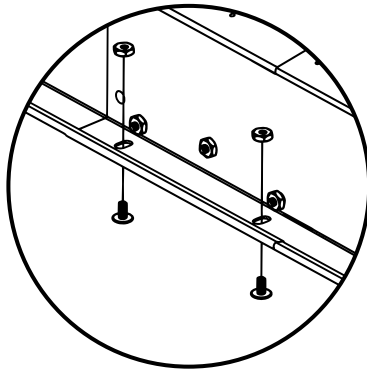

3 Repeat Steps 1 & 2 to build a second **Roof Beam Assembly**.

4 Check that the finished length of the assemblies is 96 1/8" (244,2 cm).

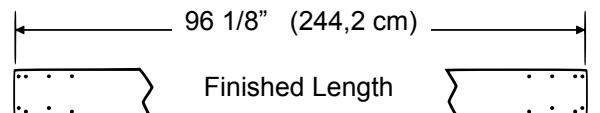
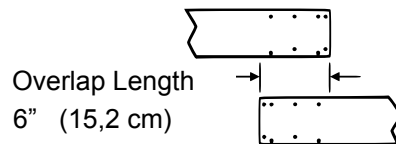

Step 4: Continued

You will need for this page:

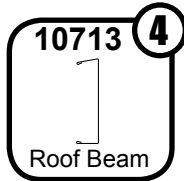
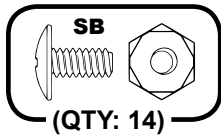

BUILD ONE (1) DOUBLE (MAIN) BEAM

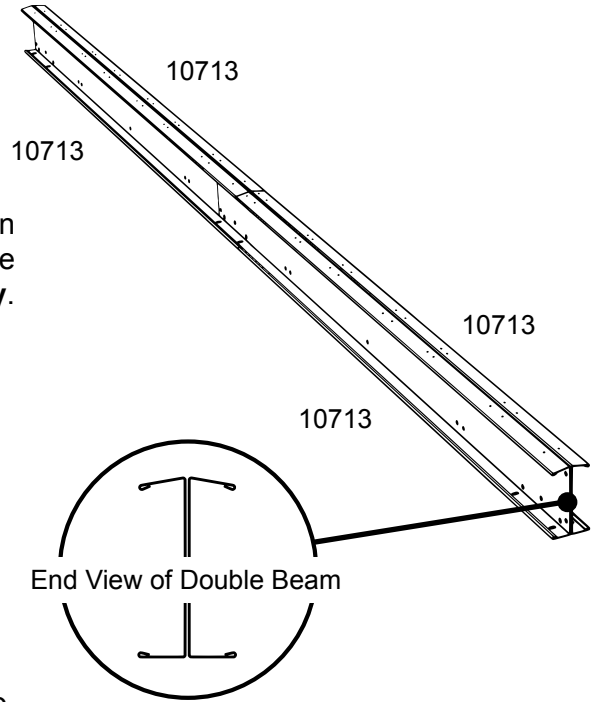

5 Overlap two (2) **Roof Beams** so that bottom slots align but **DO NOT INSERT BOLTS**. Next, overlap two (2) more **Roof Beams** to form a second **Roof Beam Assembly**. **DO NOT INSERT BOLTS**.

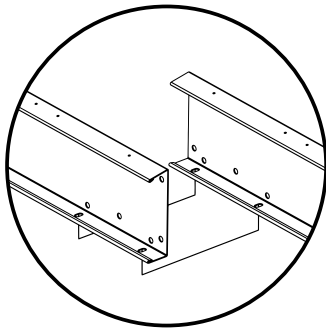

6 Place both **Roof Beam Assemblies** back-to-back to form a Double (Main) Beam. Insert ten (10) **Sand Bolts** and **Nuts** as shown below.

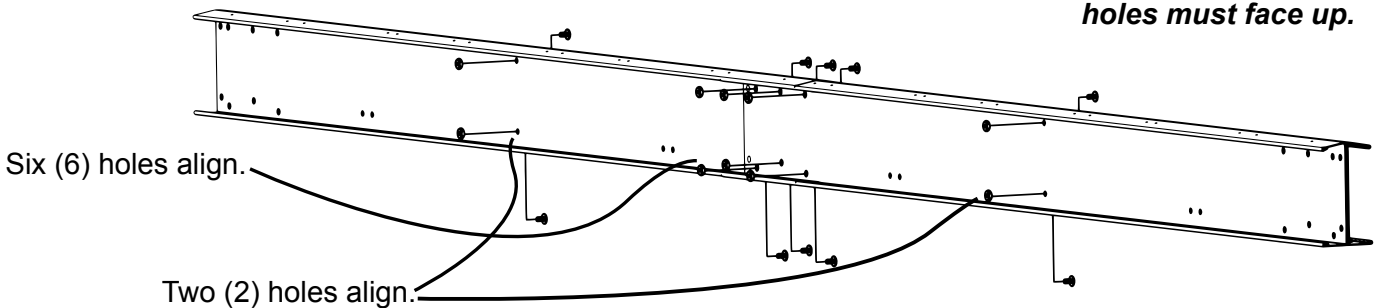

Side of Beams with small holes must face up.

7 Insert four (4) **Sand Bolts** and **Nuts** into slots from bottom. Set aside for use in Step 15.

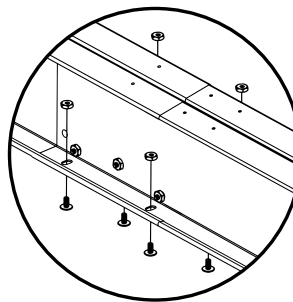

Place two (2) bolts thru slots on each side of the Beam.

8 Check that the finished length of the assembly is 96 1/8" (244,2 cm).

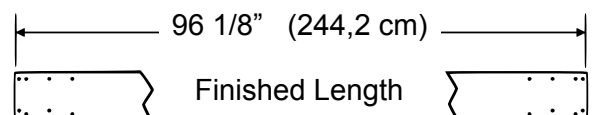
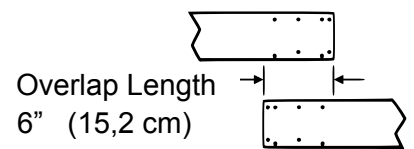

CHECK THAT ALL ASSEMBLED PARTS ARE THE CORRECT LENGTH BEFORE CONTINUING

Step 5: Door Pre-Assembly

You will need for this page:

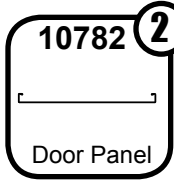
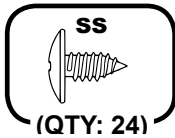
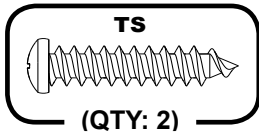

1 Start assembly by sliding the **Door Handle Brace** into the middle of the **Door** and securing it with four (4) **Sand Screws**. Then attach the **Horizontal Door Braces** to each end of **Door** using two (2) **Sand Screws** on each brace. Once installed, attach **Adhesive Pad** between leg of **Door Handle Brace** and **Door**.

2 Place the ends of **Diagonal Door Braces** with small holes under **Horizontal Door Braces** as shown. Secure all **Diagonal Door Braces** to center of **Door Handle Brace** using one (1) **Tapping Screw**. Attach all **Diagonal Door Braces** under **Horizontal Door Braces** using four (4) **Sand Screws** at each corner as shown.

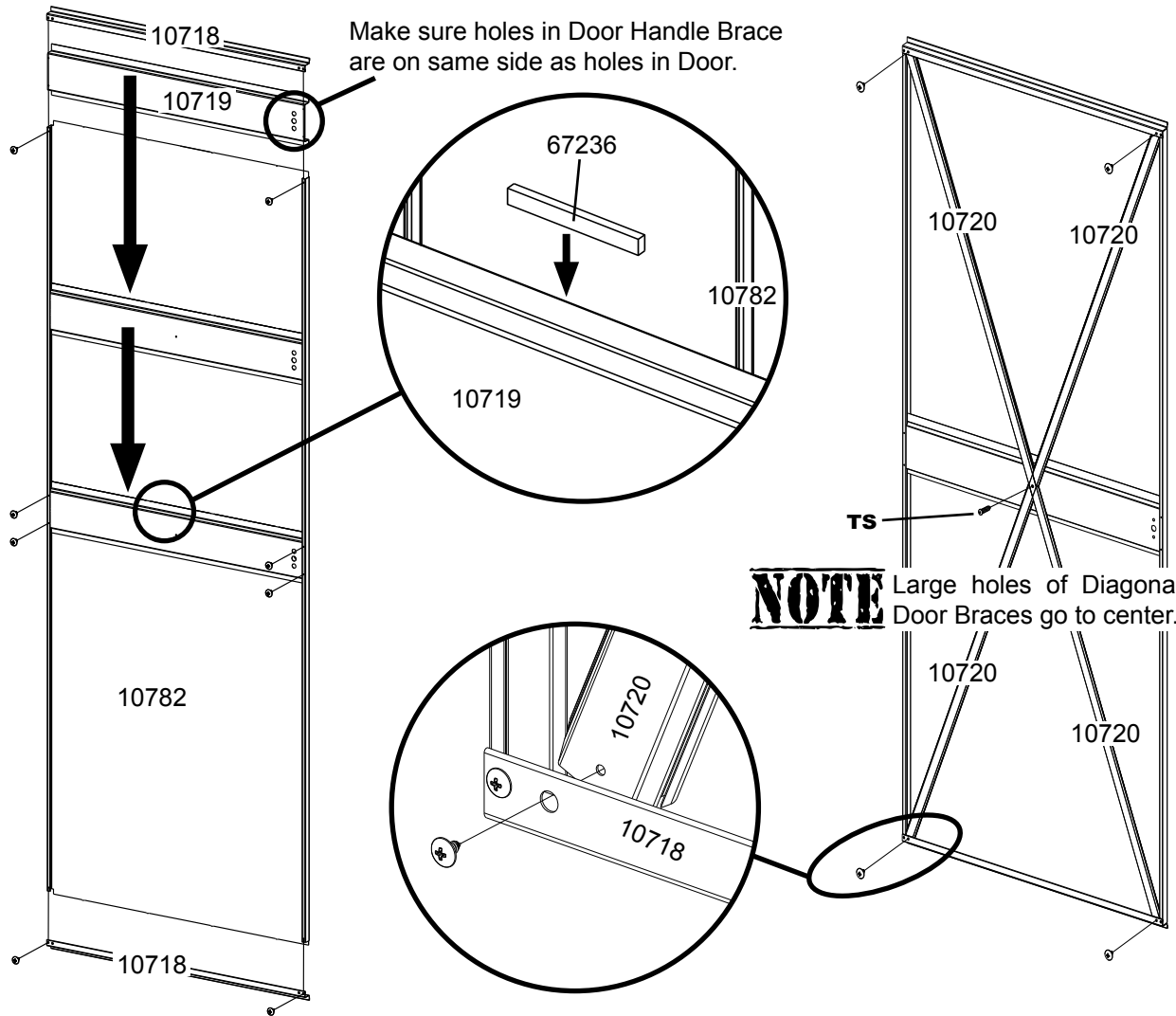

3 Repeat this process for the other **Door**.

NOTE Diagonal Door Braces attach from behind Horizontal Door Brace.

Step 6: Right Door Assembly

You will need for this page:

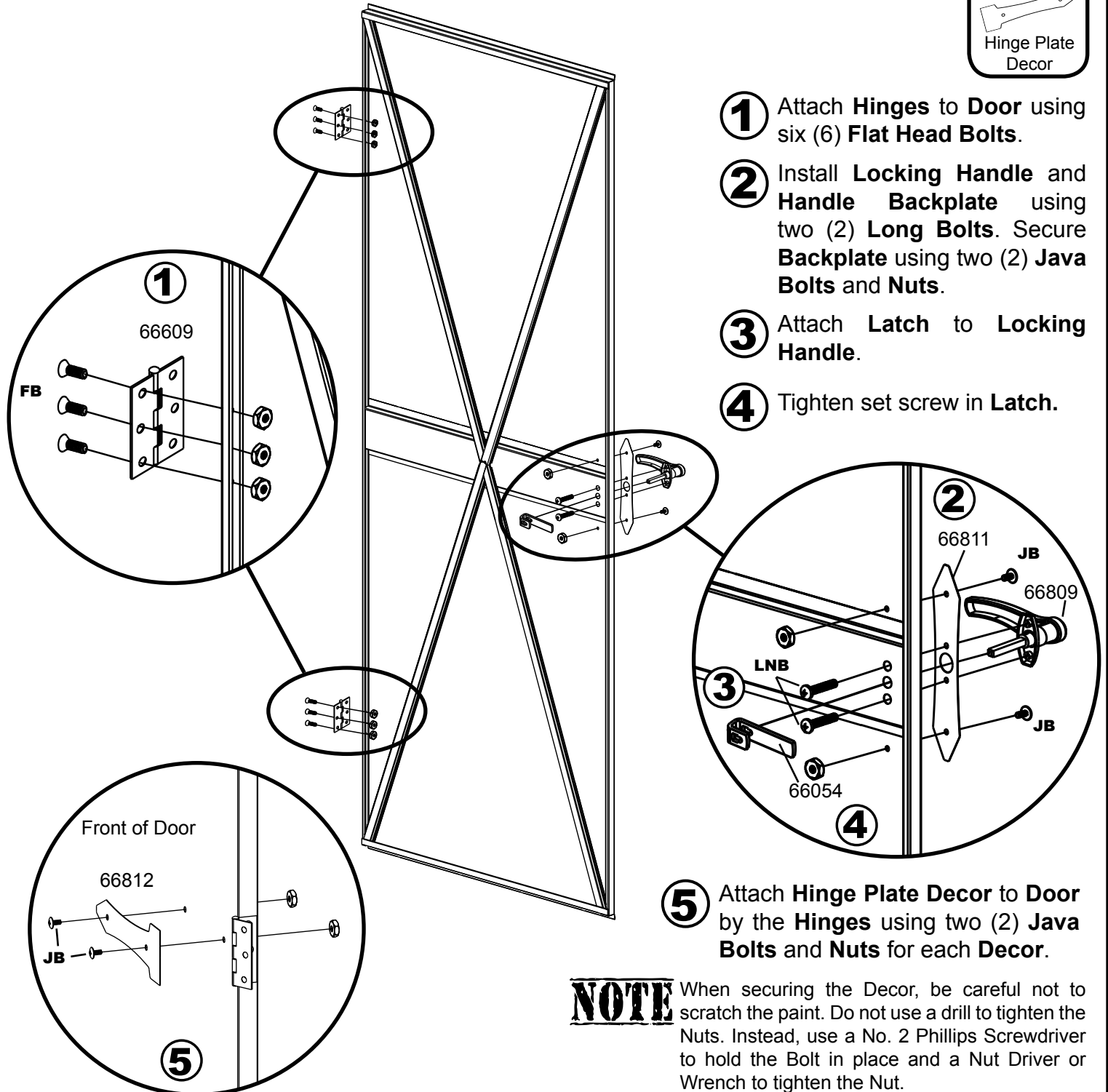
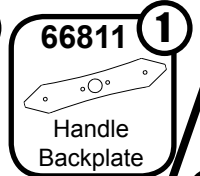
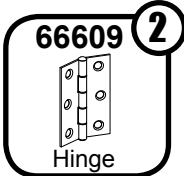
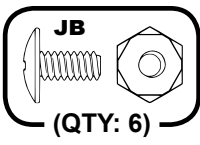
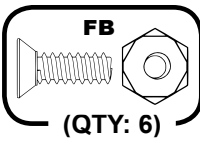
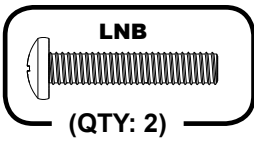

- ① Attach Hinges to Door using six (6) Flat Head Bolts.
- ② Install Locking Handle and Handle Backplate using two (2) Long Bolts. Secure Backplate using two (2) Java Bolts and Nuts.
- ③ Attach Latch to Locking Handle.
- ④ Tighten set screw in Latch.

- ⑤ Attach Hinge Plate Decor to Door by the Hinges using two (2) Java Bolts and Nuts for each Decor.

NOTE When securing the Decor, be careful not to scratch the paint. Do not use a drill to tighten the Nuts. Instead, use a No. 2 Phillips Screwdriver to hold the Bolt in place and a Nut Driver or Wrench to tighten the Nut.

Step 7: Left Door Assembly

You will need for this page:

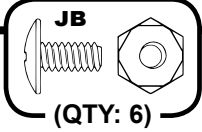
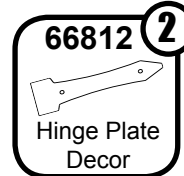
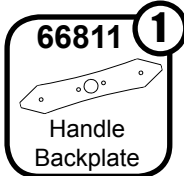
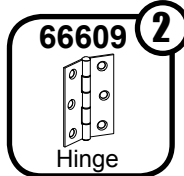
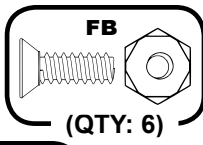
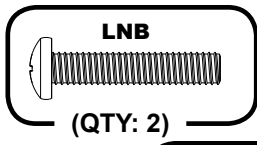

- ① Attach **Hinges** to **Door** using six (6) **Flat Head Bolts**.
- ② Install **Locking Handle** and **Handle Backplate** using two (2) **Long Bolts**. Secure **Backplate** using two (2) **Java Bolts** and **Nuts**.
- ③ Attach **Hinge Plate Decor** to **Door** by the **Hinges** using two (2) **Java Bolts** and **Nuts** for each **Decor**.

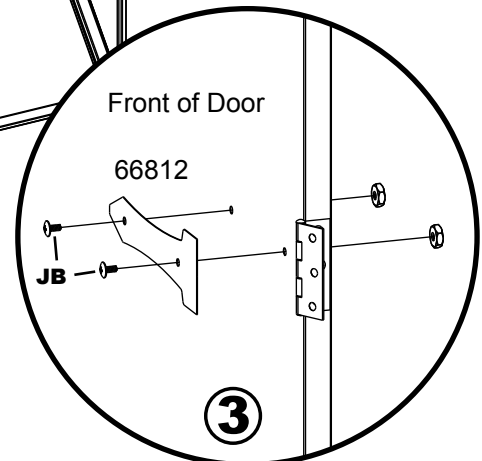
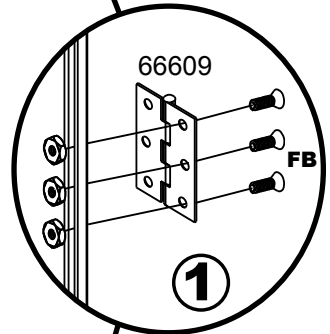
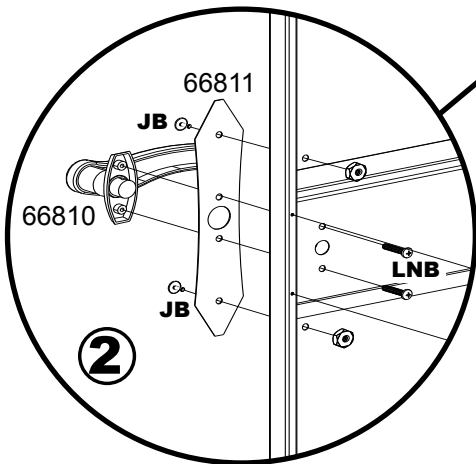
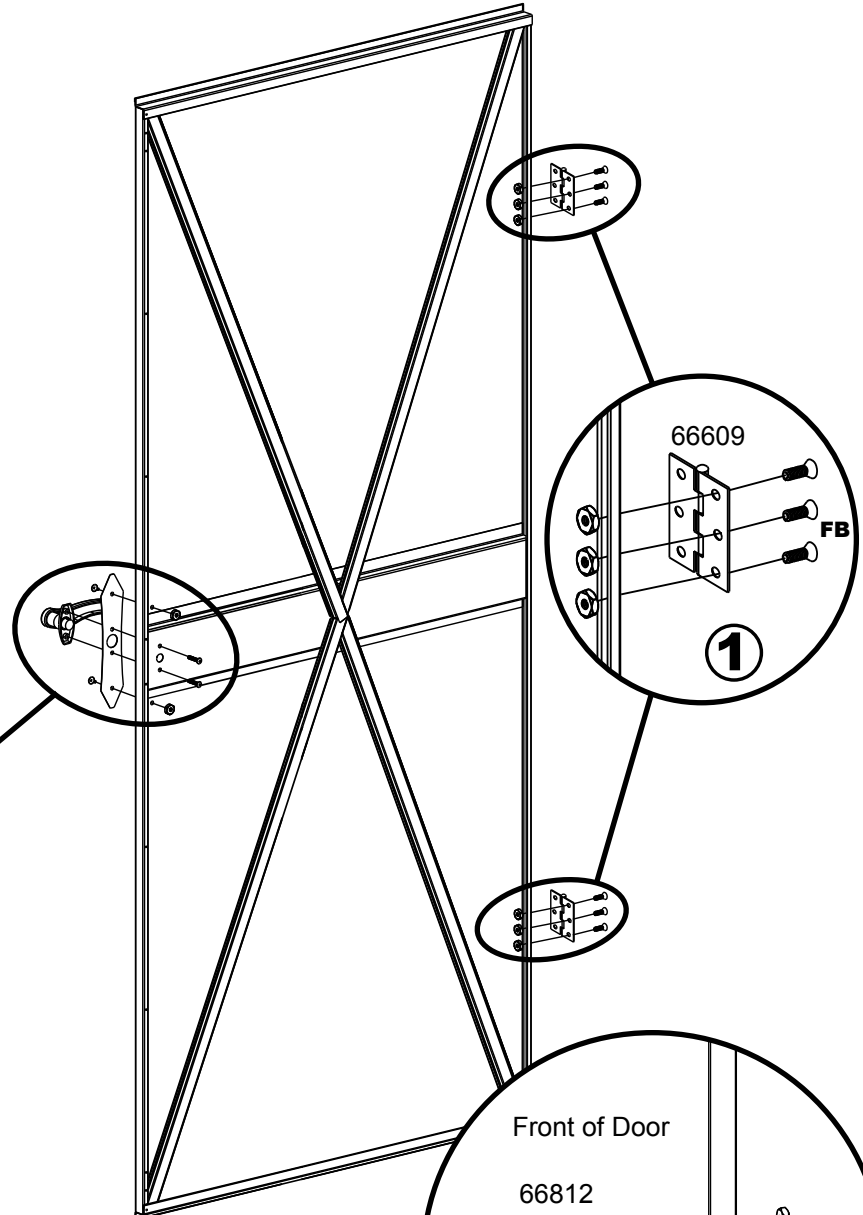

NOTE When securing the Decor, be careful not to scratch the paint. Do not use a drill to tighten the Nuts. Instead, use a No. 2 Phillips Screwdriver to hold the Bolt in place and a Nut Driver or Wrench to tighten the Nut.

Step 7: Continued

You will need for this page:

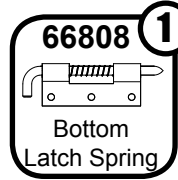
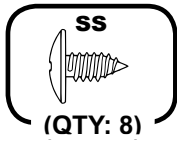

4 Remove two (2) **Screws** from left side of **Door Handle Brace** and far left **Screw** from both top and bottom **Horizontal Door Brace**. **Screws** will be reused.

Remove far left Screw from top and bottom Horizontal Door Brace to install Door Stop and Latch Springs.

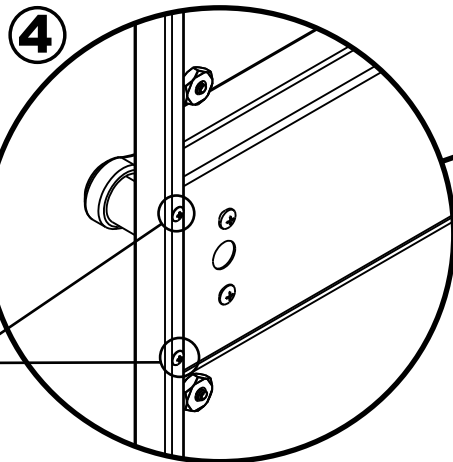
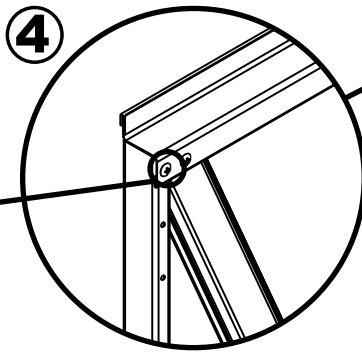

Remove Screws to install Door Stop.

5 Attach **Door Stop** and both **Top** and **Bottom Latch Springs** to left side of **Door** using the four (4) previous **Screws** as well as eight (8) additional **Sand Screws**.

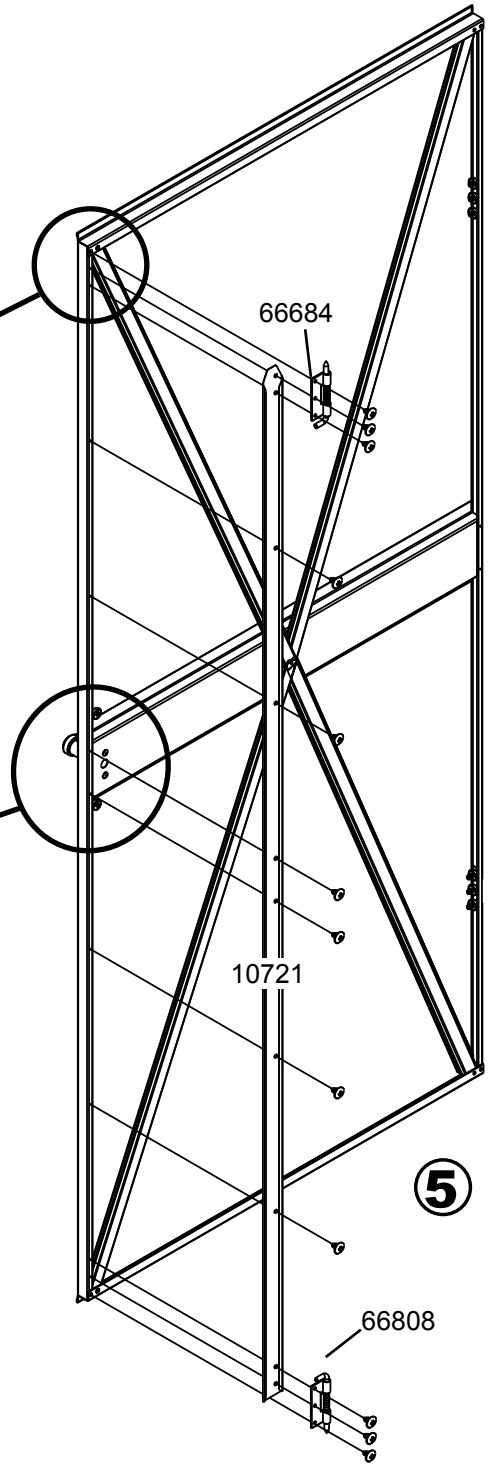

Step 8: Floor Assembly

You will need for this page:

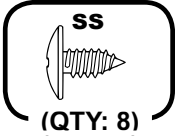

Assemblies from Step 1:

- Front/Rear Floor Frame Assemblies (2)
- Side Floor Frame Assemblies (2)

NOTE Do NOT fasten your Floor Frames to your Base at this time. You will anchor your building after it is erected. If using a Floor Frame Kit, you must wait until after assembly to install it.

Overlap Floor Frames as shown. Set Floor Frame with large holes on top at each corner.

- 1** Assemble the four (4) corners of the Floor Frame using two (2) Sand Screws at each corner as shown.

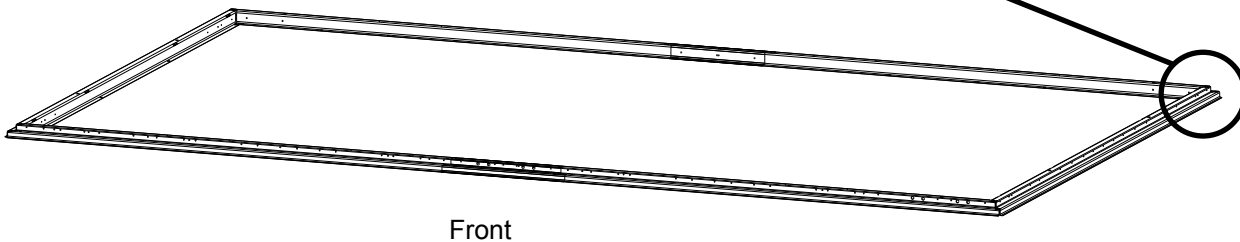
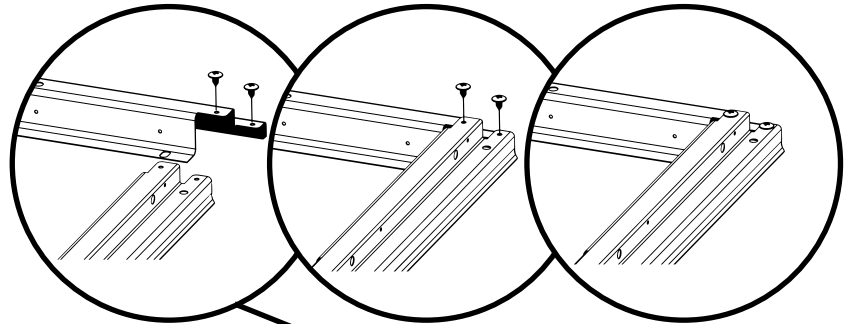

Front



When diagonal measurements are equal, the Frame is square.

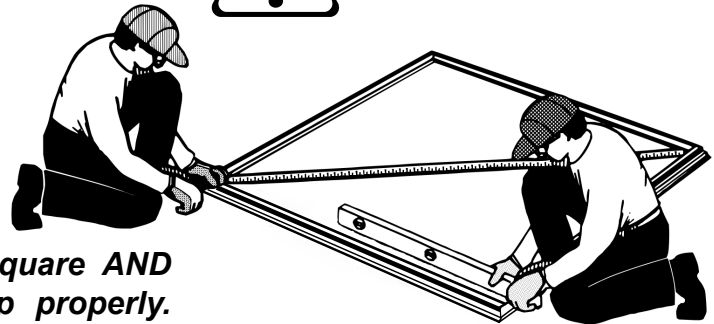

The Floor Frame must be BOTH square AND level or the holes will not line up properly.

NOTE The remainder of the building assembly requires many hours and more than one person. Do not continue beyond this point if you do not have enough time to complete the assembly today. A partially assembled building can be severely damaged by light winds.

Step 9: Corner Panels

You will need for this page:

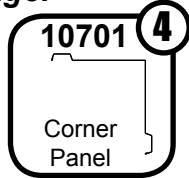
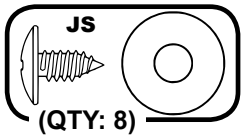

Be cautious when maneuvering and placing Panels. Once Panels begin to go up it is important to be able to finish in a timely manner to reduce the possibility of wind damage to your building.



NOTE

Use one person to support the Corner while another secures the Panels. Do not leave the Corner unsupported until it is secure.

- 1 Working one **Corner Panel** at a time, attach the **Corner Panels** to the **Floor Frame** using two (2) **Java Screws** for each **Panel** in the position shown.

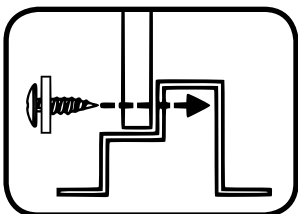
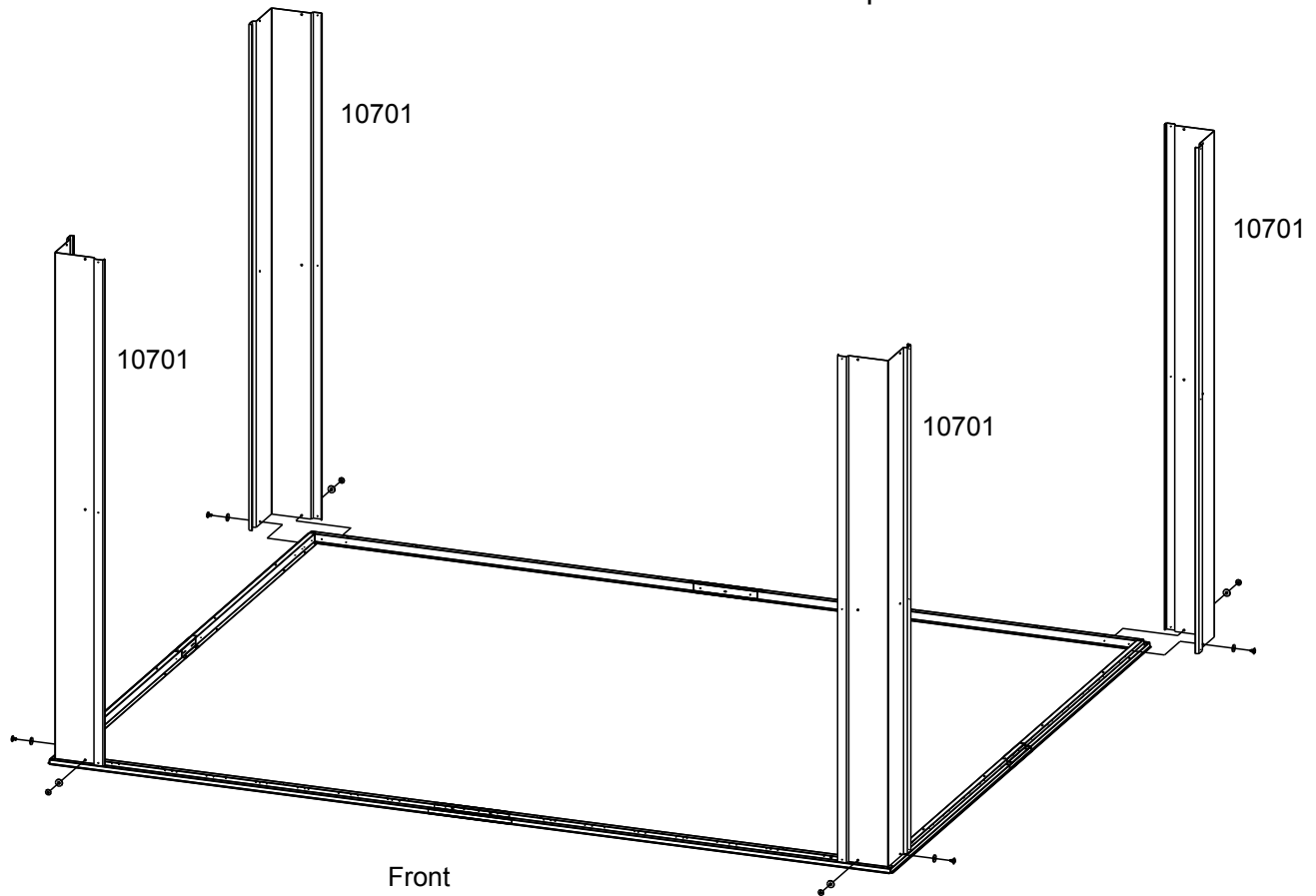

Wall Panels ALWAYS attach to the Floor Frames with Screws in the manner shown above. Rest the Panel on the Floor Frame and the holes in the Panel should line up with the holes in the Frame.

Step 10: Wall Framing

You will need for this page:

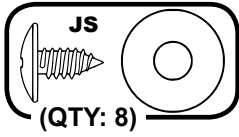

Assemblies from Step 2 and Step 3:

- Rear Wall Angle Assembly (1)
- Side Wall Angle Assemblies (2)
- Header Assembly (1)

1

- Use two (2) **Java Screws** to do each of the following:
- Install one **Side Wall Angle Assembly** first.
- Install the **Rear Wall Angle Assembly** second, sliding the end under the **Side Wall Angle Assembly**.
- Install the other **Side Wall Angle Assembly** third.
- Install the **Header Assembly** last, sliding each end under the **Side Wall Angle Assemblies**.

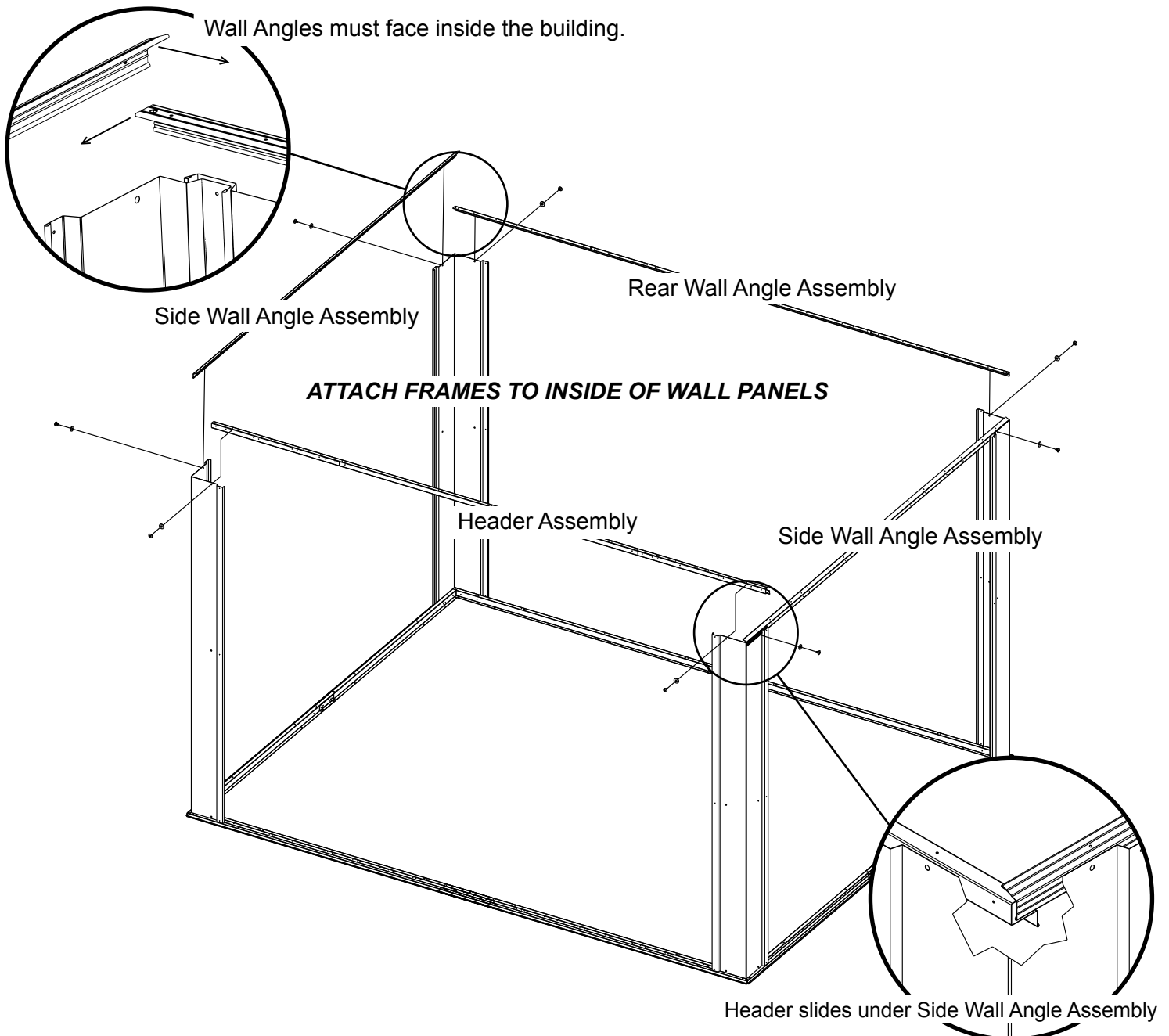

Step 11: Wall Panels

You will need for this page:

[NO HARDWARE NEEDED FOR THIS STEP]

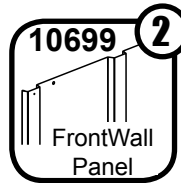
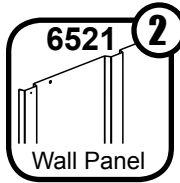
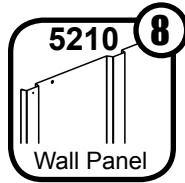

1 Lay out all **Panels** in the positions shown below. Double check that you have the correct **Panel** in each location.

NOTE

Use the diagram to the right when attaching Wall Panels.

- Secure the top row to Wall Angles.
- Secure the middle row to Wall Channels (Step 13).
- Secure the lower row to Floor Frames.
- Secure the circled holes to the Panel next to it.

FASTEN TO WALL ANGLES

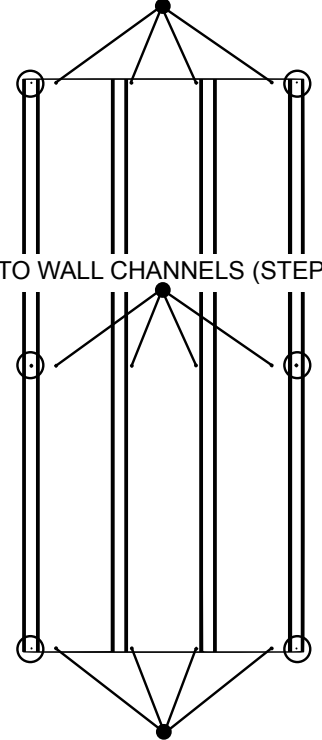

FASTEN TO WALL CHANNELS (STEP 13)

FASTEN TO FLOOR FRAMES

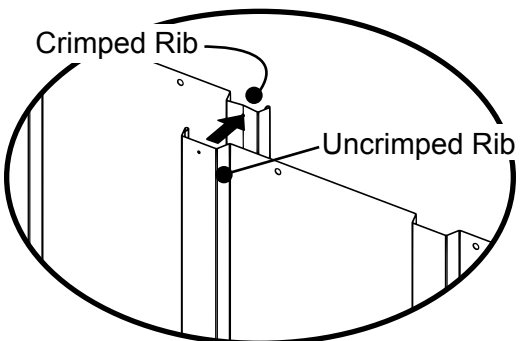
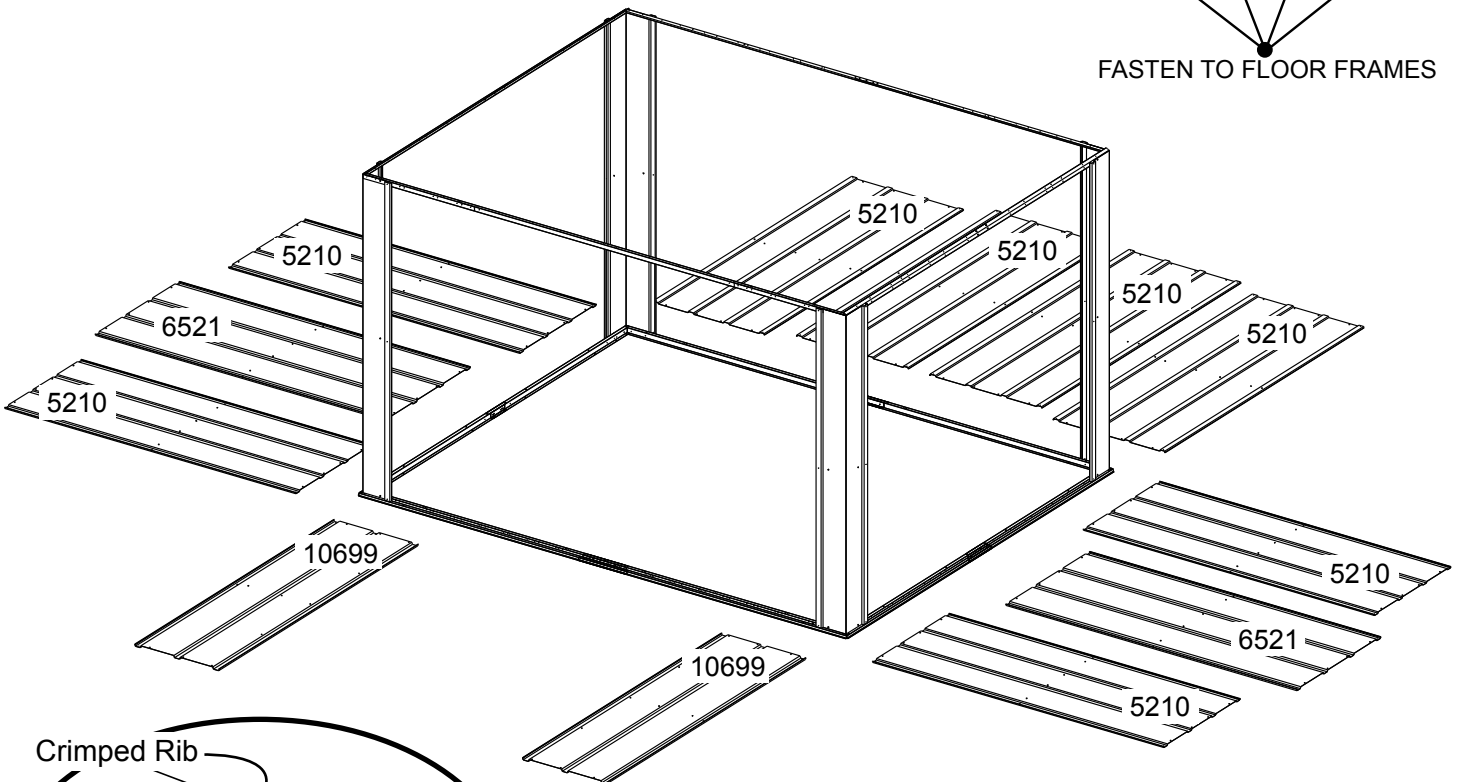

Whenever a crimped rib and an uncrimped rib meet, the crimped rib should be placed **UNDER** the uncrimped rib if possible.

Step 11: Continued

You will need for this page:

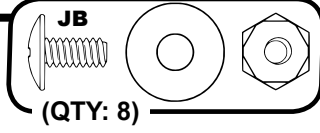
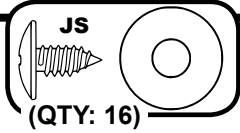
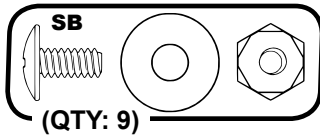
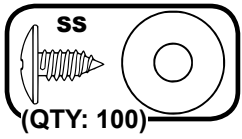

NOTE Corner Panels lay over Wall Panels.

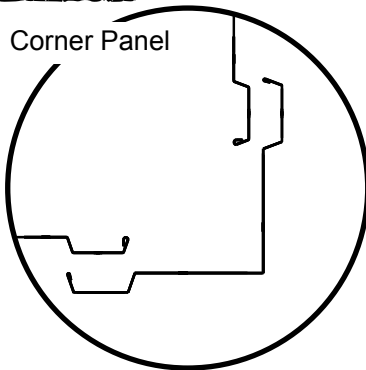

2 Working one side at a time, lift the **Panels** into place and secure top and bottom of **Panels** with **Screws**. Be sure to use **Java Screws** on **Corner Panels** and **Sand Screws** on **Wall Panels**.

3 Place a **Bolt** and **Nut** through the center hole of the **Panel** everywhere **Panels** overlap, as shown below. Be sure to use **Java Bolts** and **Nuts** on **Corner Panels** and **Sand Bolts** and **Nuts** on **Wall Panels**.

4 Leave the holes in **Front Wall Panel** open as shown below.

Use bolts to attach Wall Panels where Wall Angles overlap.

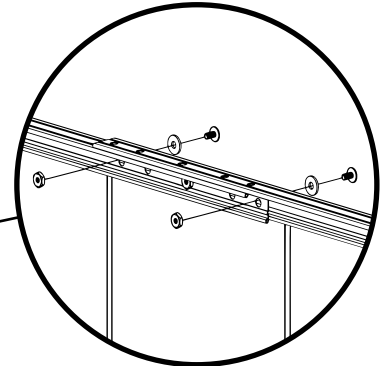

3

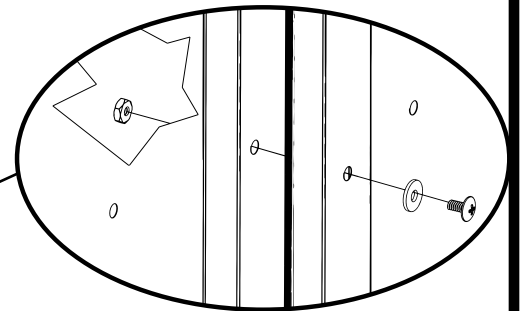

Place bolt thru center hole where Panels overlap.

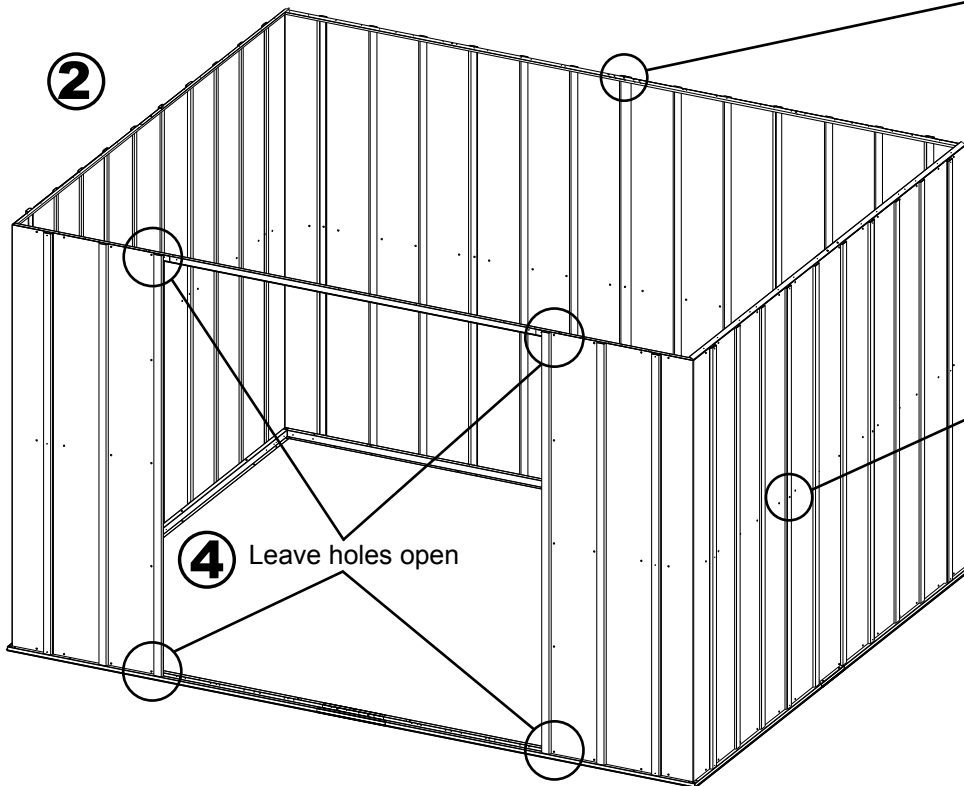

4 Leave holes open

Attach Wall Panels with screws thru all holes in top and bottom of Panels.

Step 12: Door Jambs

You will need for this page:

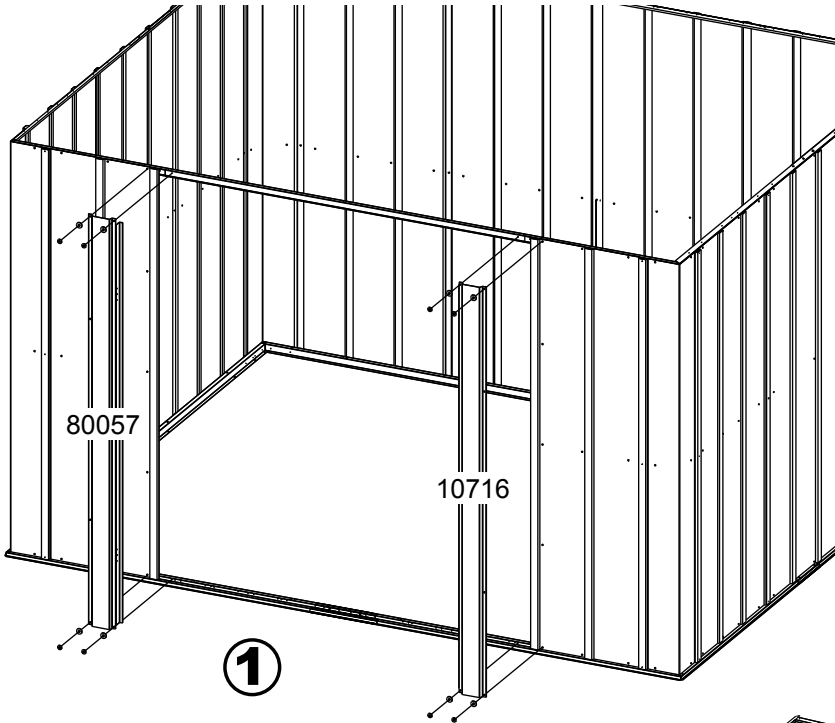
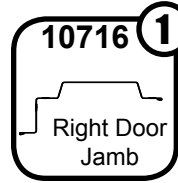
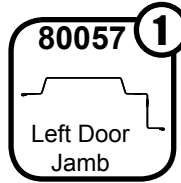
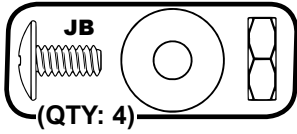
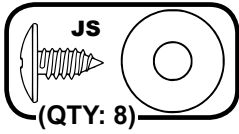

1 Secure **Door Jambs** with two (2) **Java Screws** in the top and bottom of each **Door Jamb** as shown.

2 Secure **Door Jamb** to **Panel** using two (2) **Java Bolts** and **Nuts** as shown below.

3 Leave the holes in the center of each **Door Jamb** open as shown below.

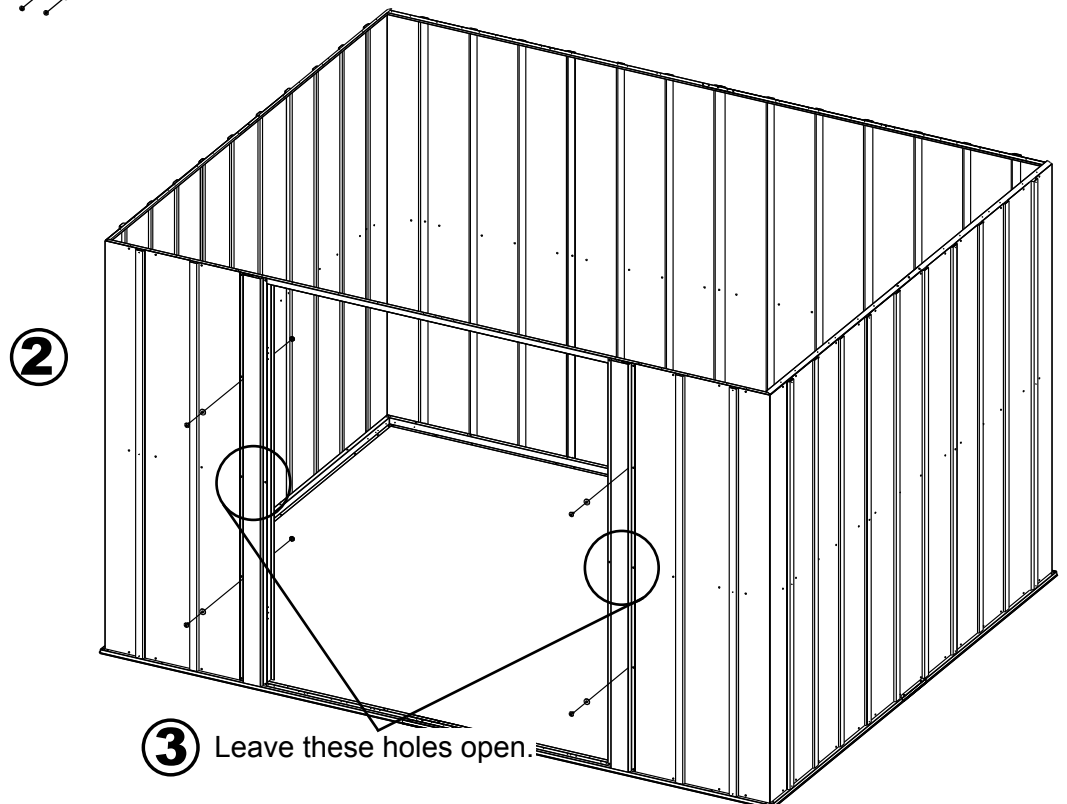

Step 13: Wall Channels

You will need for this page:

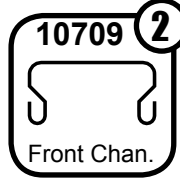
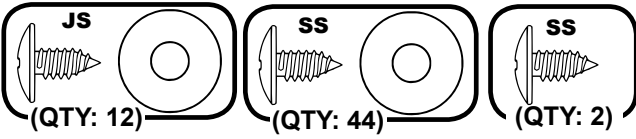

Assemblies from Step 2:

- Rear Wall Channel Assembly (1)
- Side Wall Channel Assemblies (2)

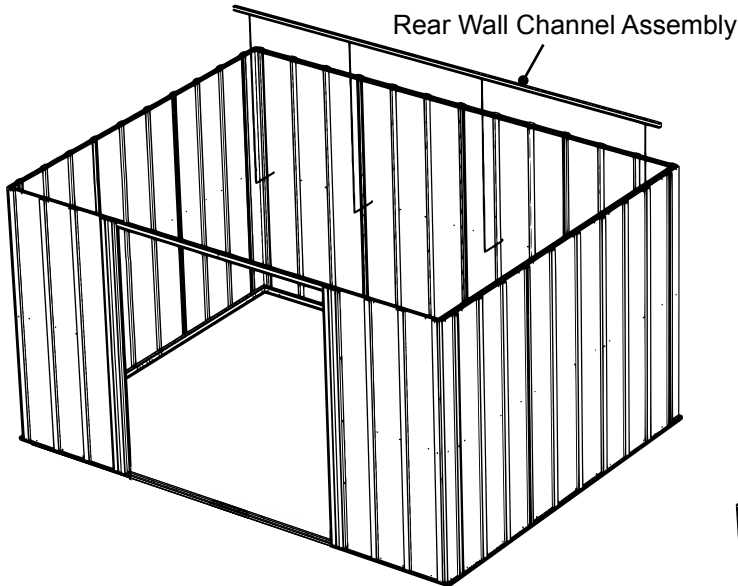

- 1** Install **Rear Wall Channel Assembly** by placing **Screws** through all remaining holes in **Wall Panels**. Be sure to use **Java Screws** on **Corner Panels** and **Sand Screws** on **Wall Panels**.

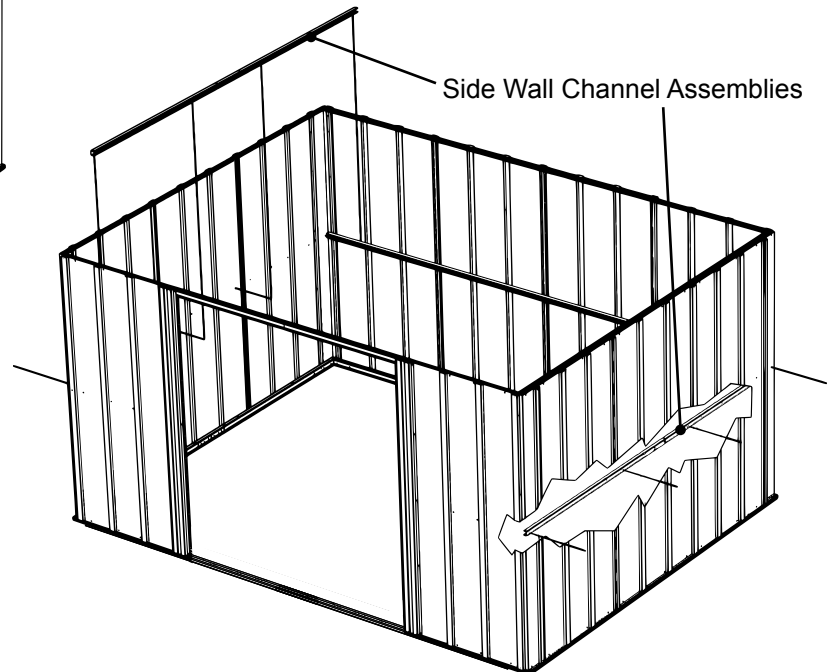

- 2** Install **Side Wall Channel Assemblies** by placing **Screws** through all remaining holes in **Wall Panels**. Be sure to use **Java Screws** on **Corner Panels** and **Sand Screws** on **Wall Panels**.

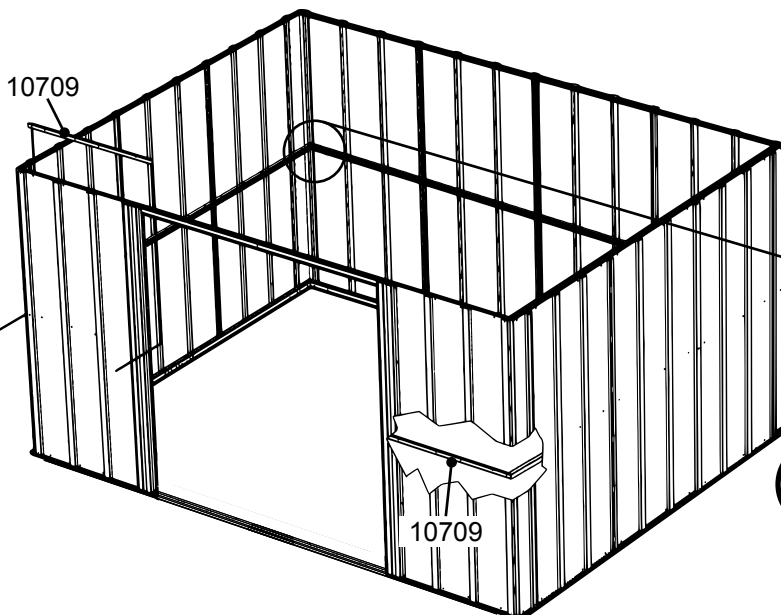

Insert screw where Channels meet.

- 3** Install **Front Wall Channels** by placing **Screws** through all remaining holes in **Wall Panels** and **Door Jambs**. Be sure to use **Java Screws** on **Corner Panels** and **Door Jambs**. Use **Sand Screws** on **Wall Panels**. Insert a **Sand Screw** in both rear corners where **Side** and **Rear Wall Channels** meet.

Install Channels on inside of building.

Step 14: Gables

You will need for this page:

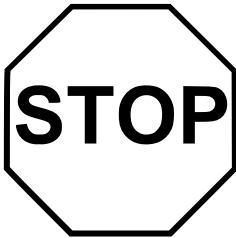
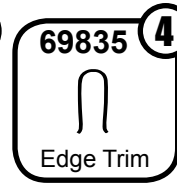
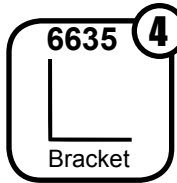
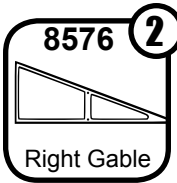
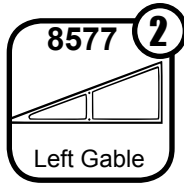
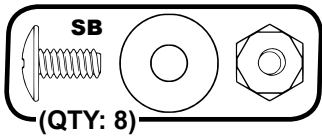

GABLES ARE STACKED TOGETHER DURING SHIPPING AND MAY BE MISTAKEN FOR ONE GABLE! SEPARATE GABLES BEFORE CONTINUING.

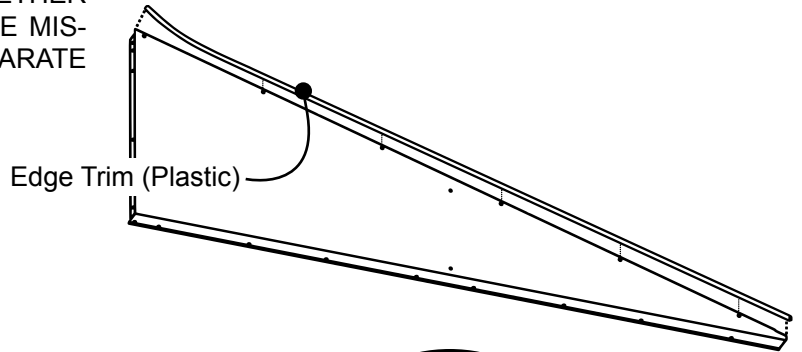
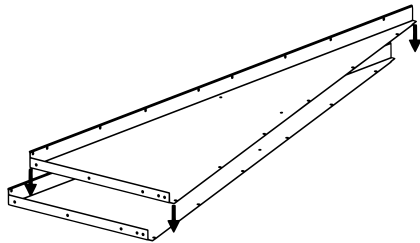

Edge Trim MUST cover Gable edge.

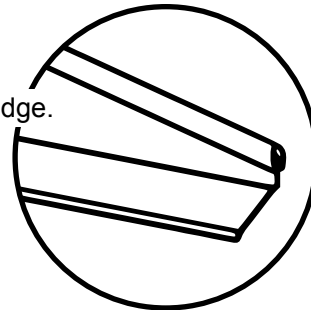

! Install Edge Trim to cover Gable Edge BEFORE doing ANY work with Gables. Failure to do so could result in injury.

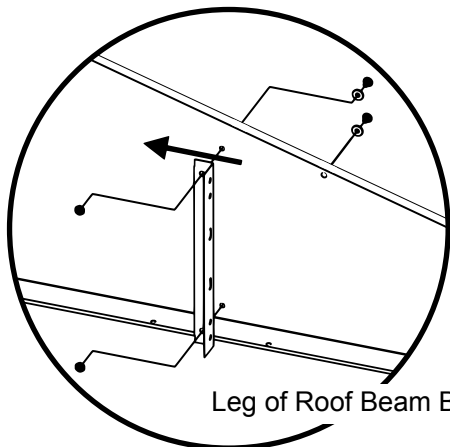
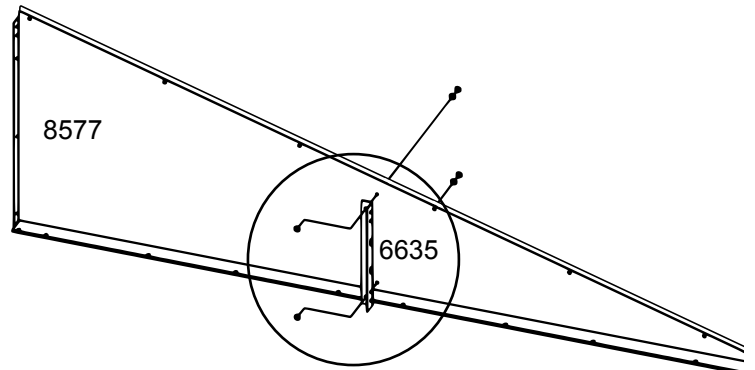
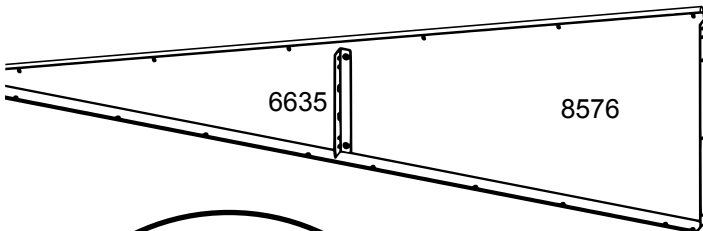

Leg of Roof Beam Bracket must face center of Gable as shown.

1 Install **Roof Beam Brackets** on all **Gables** using two (2) **Sand Bolts** and **Nuts** per **Bracket**. Leg of **Bracket** must face center of **Gable** as shown.

Step 14: Continued

You will need for this page:

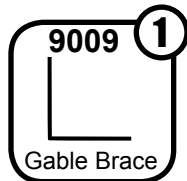
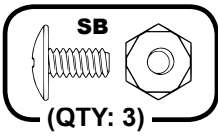
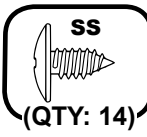

Gable must fit UNDER Side Wall Angle at corner.

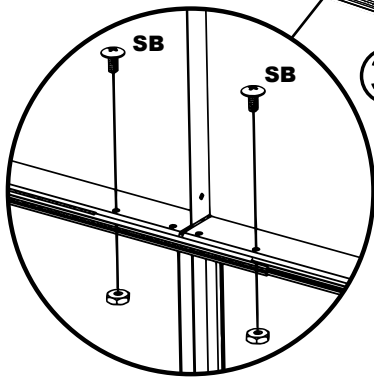
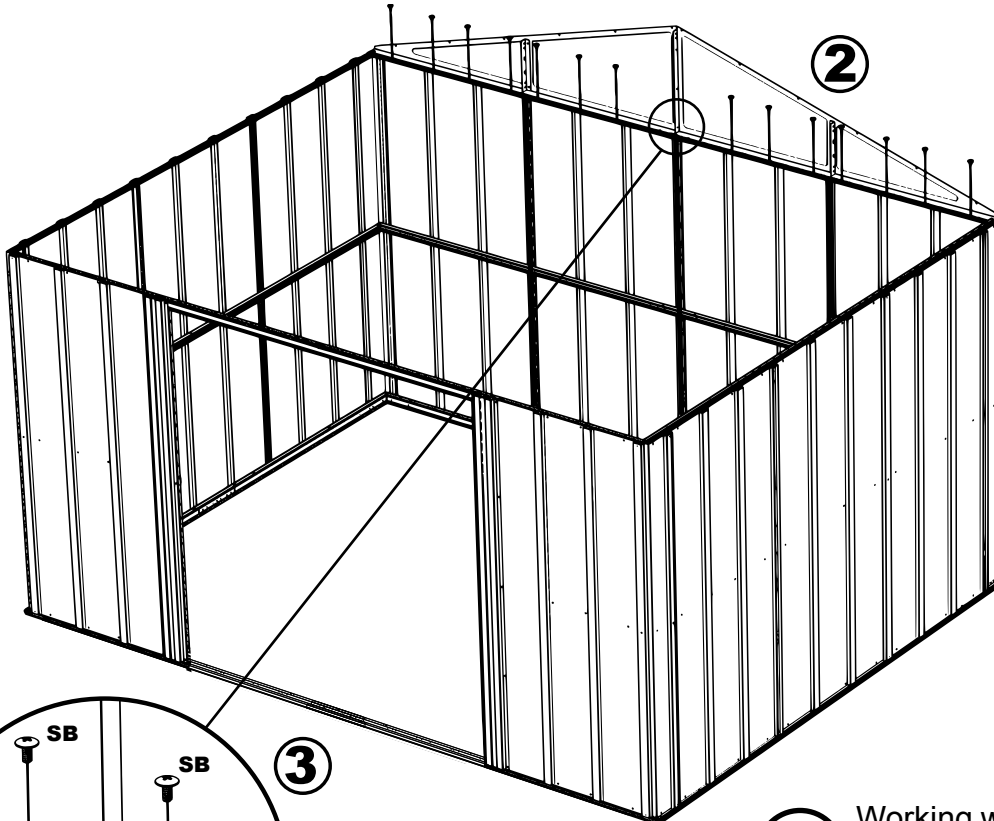
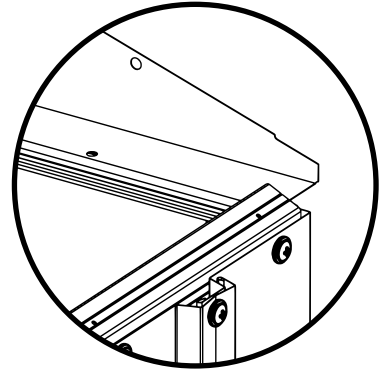

Use bolts where Angles overlap.

② Working with one (1) **Gable** at a time, attach the **Rear Gables** to the **Rear Wall Angle** with fourteen (14) **Sand Screws**.

③ Insert two (2) **Sand Bolts** and **Nuts** where **Wall Angles** overlap.

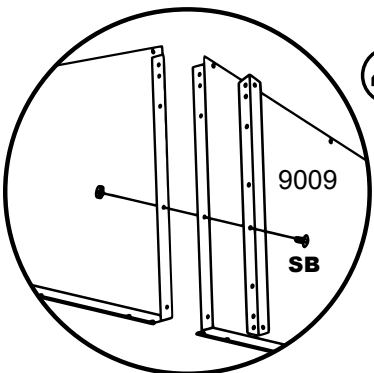

Attach Brace with bolt thru second hole from bottom only.

④ To secure **Gables** together, position the **Gable Brace** as shown and insert a single **Sand Bolt** and **Nut** through the second hole from the bottom only.

Step 14: Continued

You will need for this page:

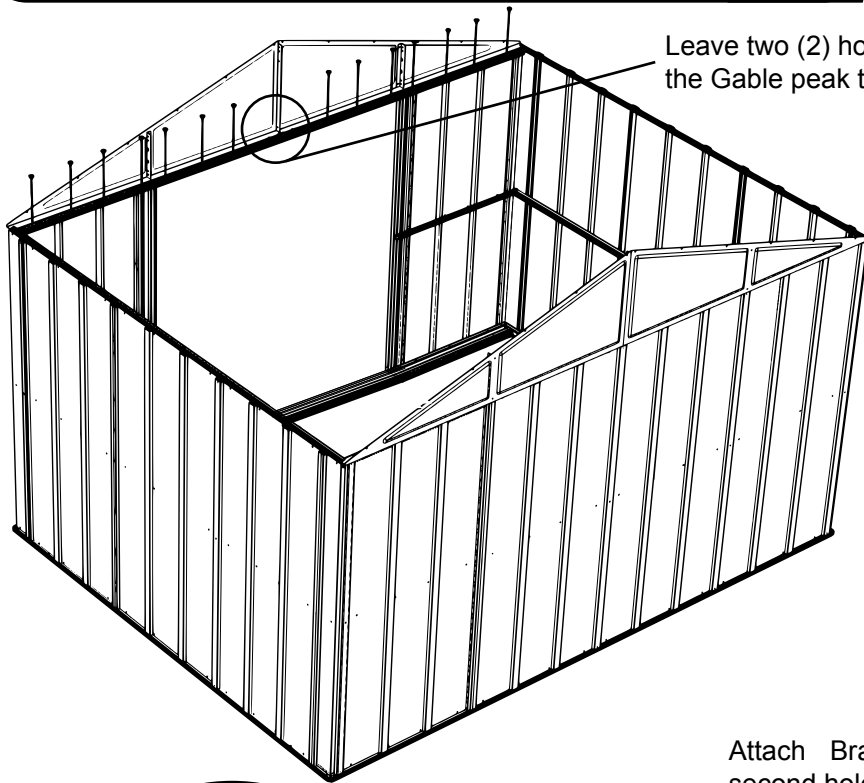
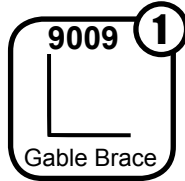
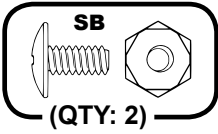
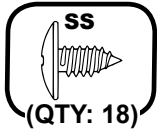

Leave two (2) holes open on each side of the Gable peak to attach Track Support.

5 Working with one **Gable** at a time, attach the front **Gables** to the **Header** with **Sand Screws**. Do not insert screws into the two (2) holes closest to the peak of each **Gable**. These will be used to attach the **Track Support** later.

6 To secure **Gables** together, position the **Gable Brace** as shown and insert a single **Sand Bolt** and **Nut** through the second hole from the bottom only.

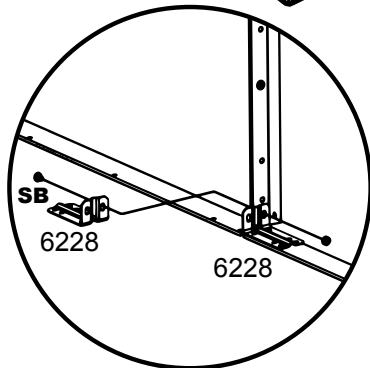

Install Track Support.

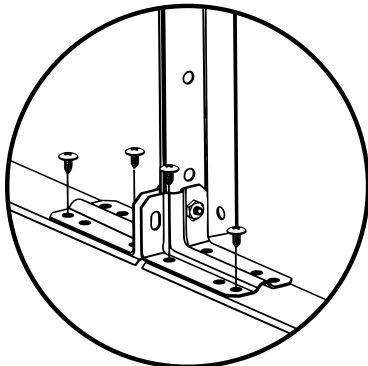

7 Position **Track Support** as shown. Secure **Track Supports** to **Gable** using one (1) **Sand Bolt** and **Nut**. Secure to **Header** using two (2) **Sand Screws** per side.

Attach Brace with bolt thru second hole from bottom only.

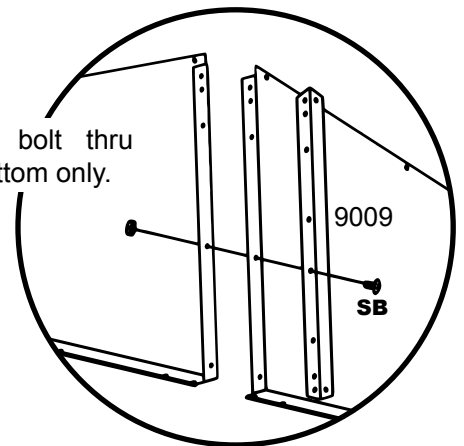

Step 15: Roof Framing

You will need for this page:

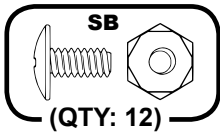

Assemblies from Step 4:

- Double (Main) Roof Beam Assembly (1)
- Single Roof Beam Assemblies (2)

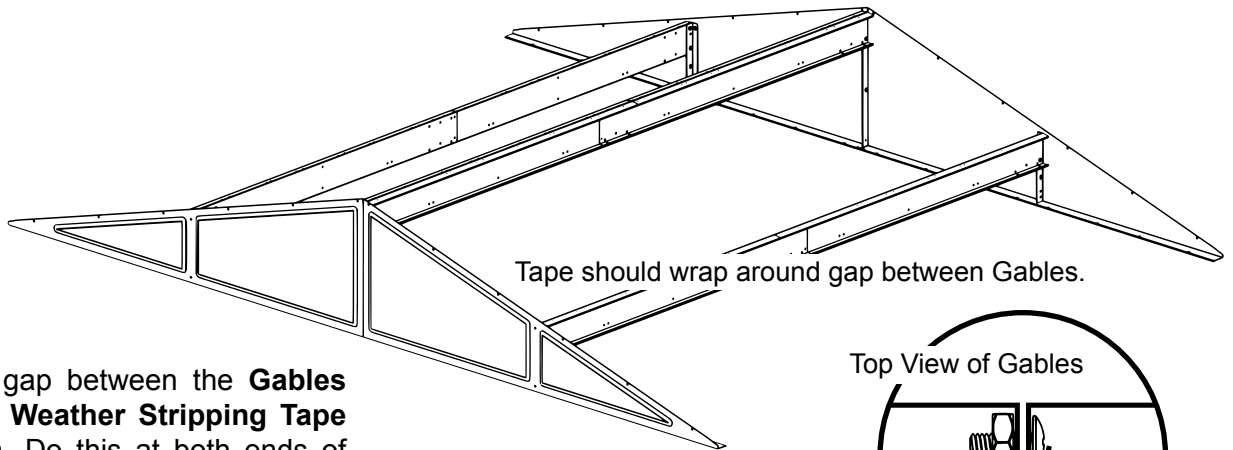

Tape should wrap around gap between Gables.

Top View of Gables

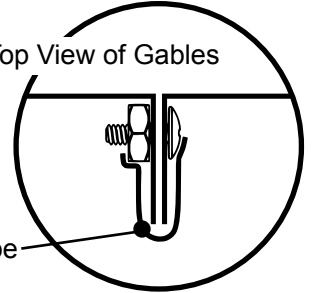

Weather Stripping Tape

1 Seal the gap between the **Gables** using the **Weather Stripping Tape** as shown. Do this at both ends of the building before installing **Roof Beams**.

2 Position the **Roof Beams** as shown below and install using two (2) **Sand Bolts** and **Nuts** per side. Install the Main (center) Beam first.

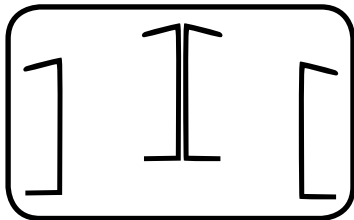

Beam End Views

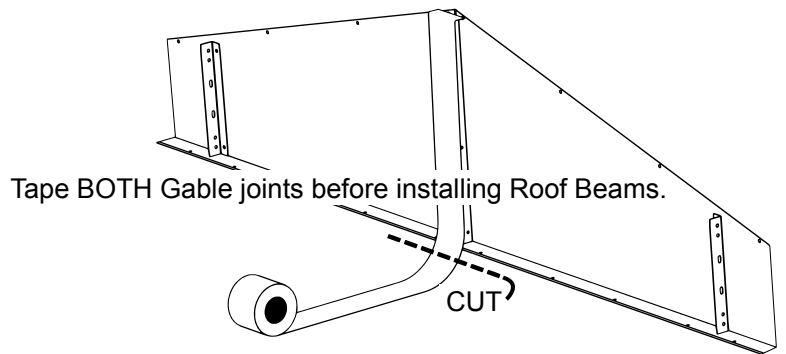

Tape BOTH Gable joints before installing Roof Beams.

CUT

Angled side of Beams must face up.

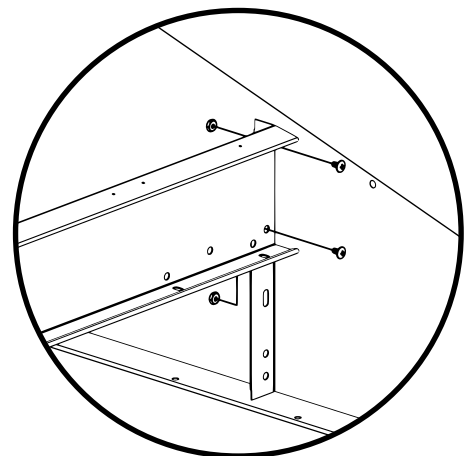
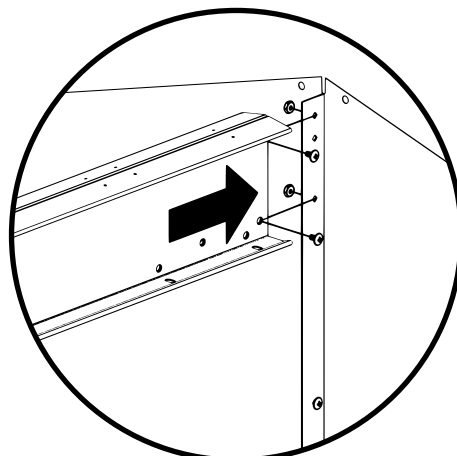
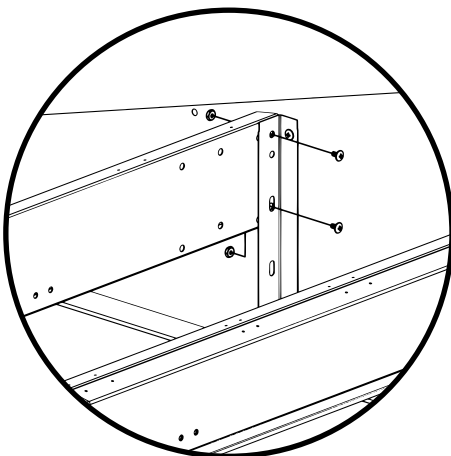

Step 15: Continued

You will need for this page:

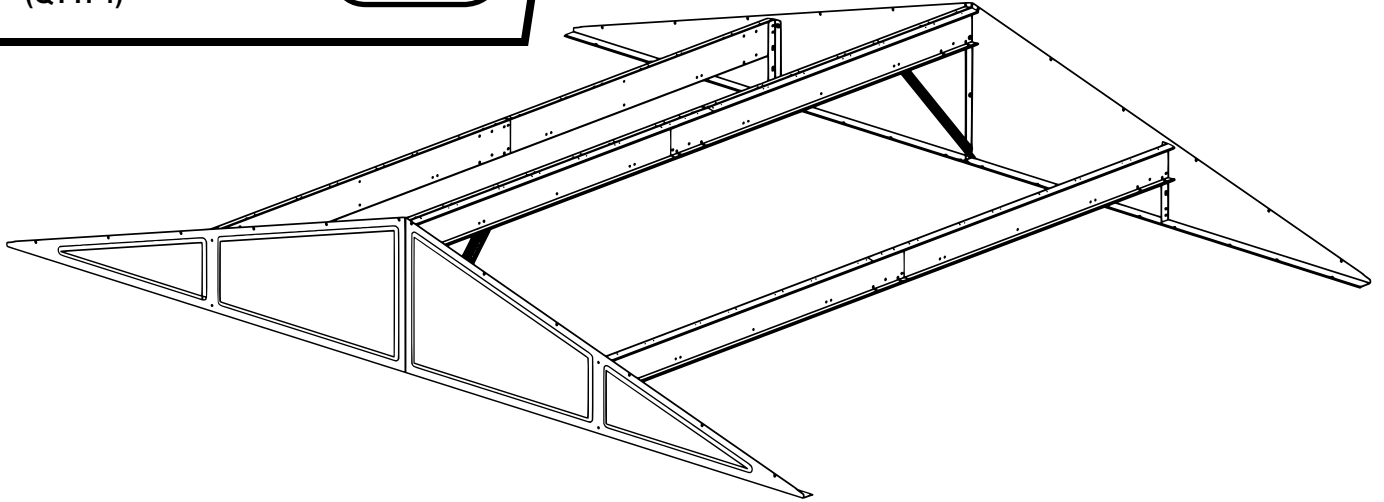
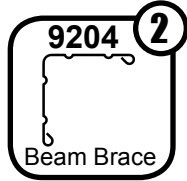
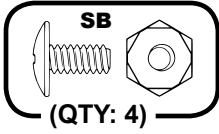

3 Attach the **Roof Beam Brace** to the **Gable** with one (1) **Sand Bolt** and **Nut** as shown and rotate to align with **Roof Beam**. Secure to **Roof Beam** with one (1) **Sand Bolt** and **Nut** as shown. Repeat for other side.

Tab on Roof Beam Bracket mounts between Main Roof Beam.

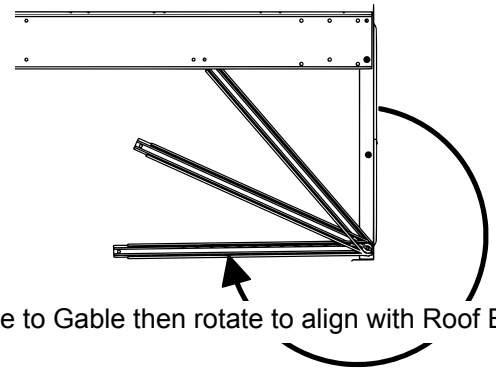

Attach Brace to Gable then rotate to align with Roof Beam.

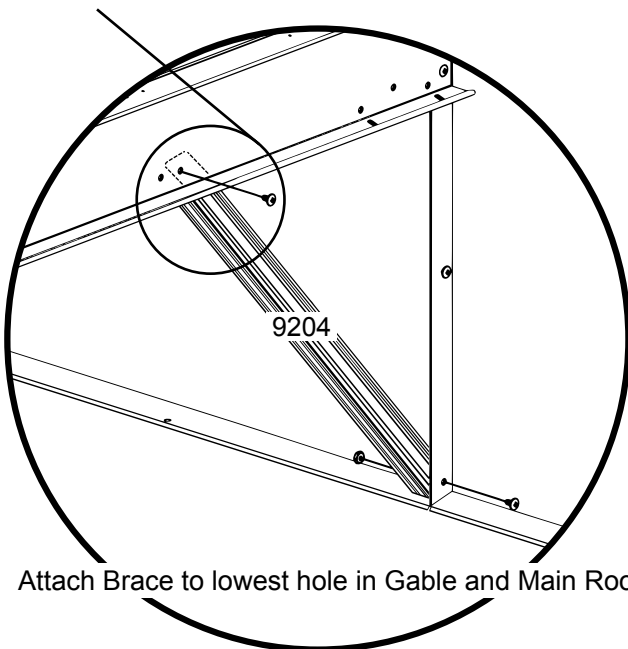

Attach Brace to lowest hole in Gable and Main Roof Beam.

Roof Install Prep Page

Use the information on this page to complete steps 16 thru 17.

NOTE If Roof Beam holes do not line up with Roof Panel holes, shift the building from left to right. If this does not help, your building may not be level. Shim the corners until holes line up.

NOTE Measure the building diagonally again to make sure the building is square. The building should be square at the base and at the top. This will make roof panels fit better and holes will better align.

NOTE Be sure to carefully follow the Roof Panel Placement Order Diagram on this page.

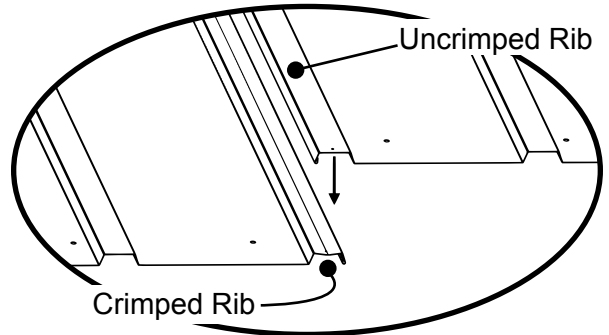
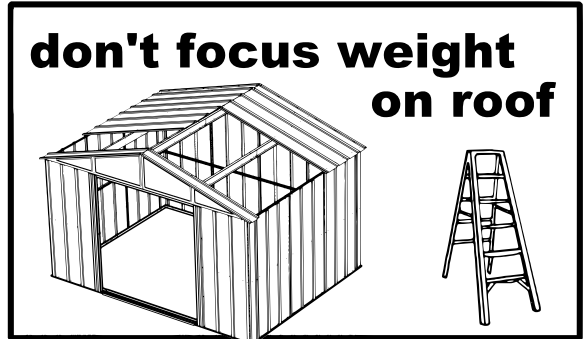

Whenever a crimped rib and an uncrimped rib meet, place the crimped rib UNDER the uncrimped rib.

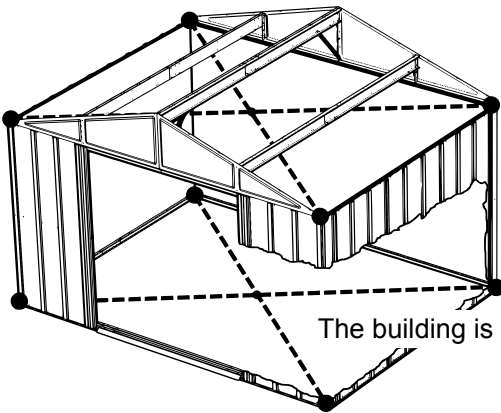

The building is square when diagonal measurements are equal.

Roof Panel Placement Order

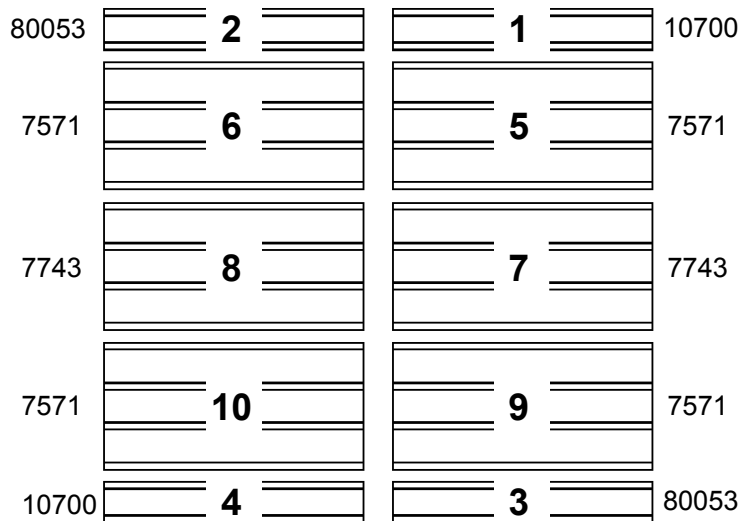

FRONT

Step 16: Roof Corners

You will need for this page:

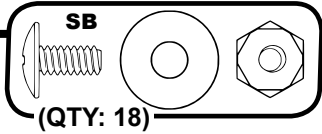
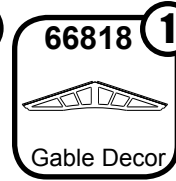
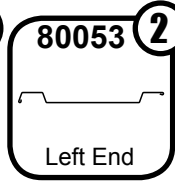
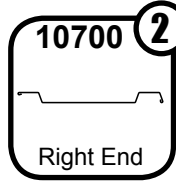
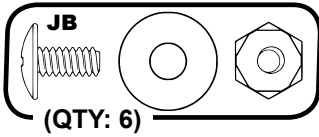
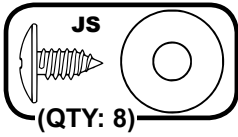

- 1** Secure the first **End Panel** in rear of unit to the **Main Roof Beam** by placing a **Java Screw** in hole #1 (from the diagram below). Carefully remove the **Gable Edge Trim** once the **Panel** is in position.
- 2** Fasten **Panel** to **Gable** by placing **Sand Bolts** through holes #2 - #7. Fasten the holes in order.
- 3** Secure the **Panel** to the **Lower Roof Beam** by placing a **Java Screw** in hole #8. Repeat for other rear **End Panel**.

- 4** Repeat Step 1 for front **End Panels**.
- 5** Fasten front **End Panels** to **Gable** by placing **Sand Bolts** through holes #2, #6, and #7. Fasten the holes in order.
- 6** Secure the front **End Panel** to the **Lower Roof Beam** by placing a **Java Screw** in hole #8. Repeat for other front **End Panel**.
- 7** Attach **Gable Decor** to front **Gables** and **End Panels** using **Java Bolts** through holes #3, #4, and #5.

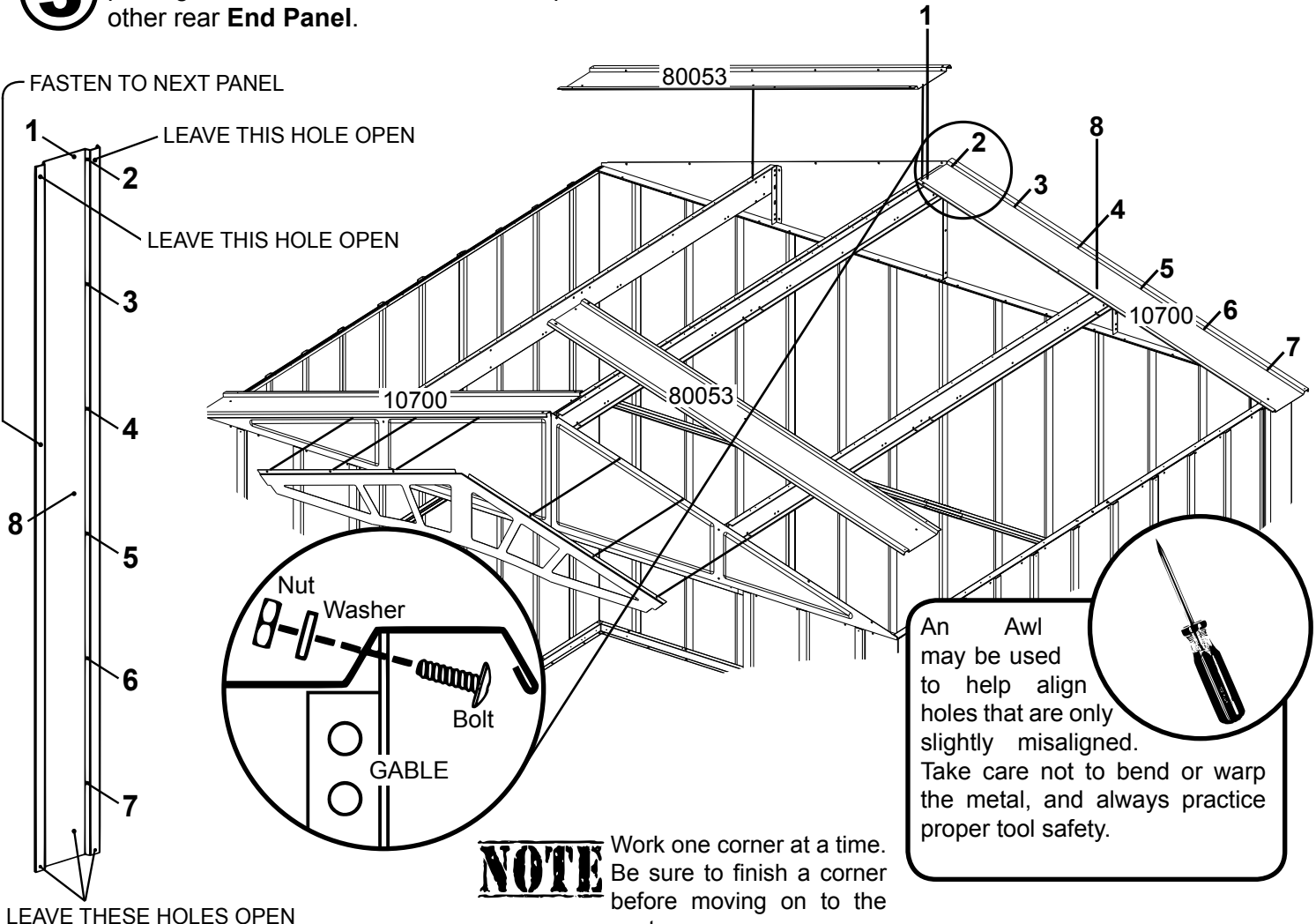

An Awl may be used to help align holes that are only slightly misaligned. Take care not to bend or warp the metal, and always practice proper tool safety.

Step 17: Roof Assembly

You will need for this page:

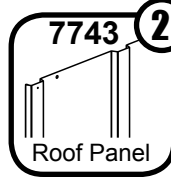
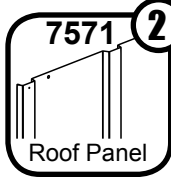
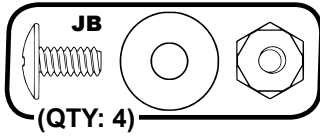
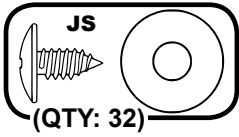

FASTEN TO RIDGE CAP (NEXT TWO PAGES)

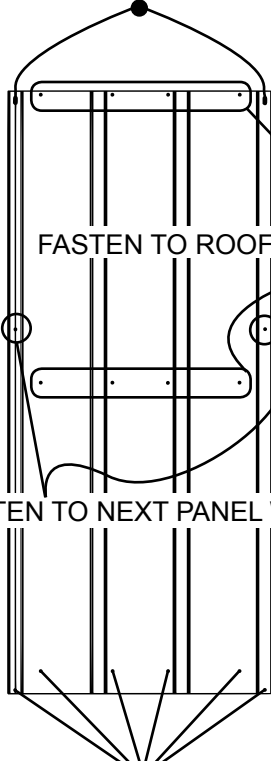

FASTEN TO ROOF BEAMS WITH SCREWS

FASTEN TO NEXT PANEL WITH BOLT AND NUT

DO NOT FASTEN AT THIS TIME

3

1

Begin **Weather Stripping** the roof ridge. Apply more of the weather stripping after each additional **Panel** is installed.

2

Attach **Panels #5 - #8** in the order given in the diagram on page 36. Use the diagram to the left while assembling the roof.

3

Do not fasten the holes on the lower end of the **Panels**. Do not install **Panels #9 or #10** yet. Double check that **Panels** are installed in the correct position. The part numbers listed in the Roof Panel Placement diagram on page 36 must match the numbers inked on the **Panels**.

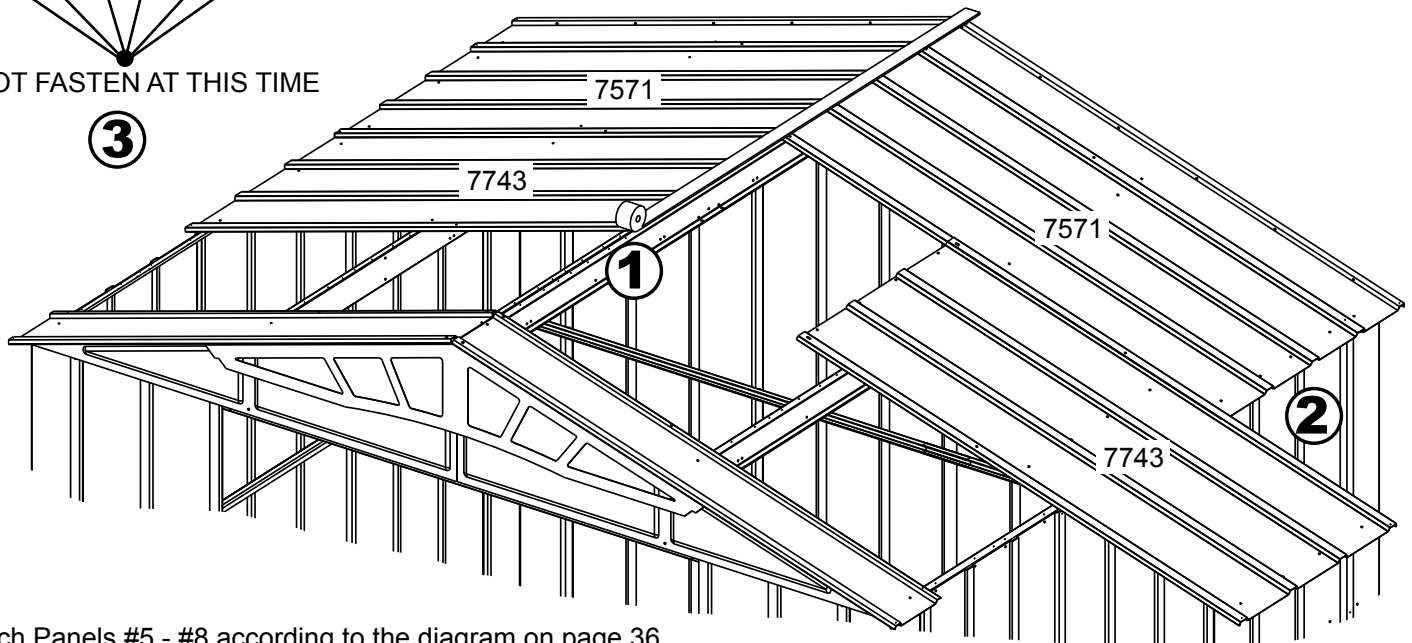

Attach Panels #5 - #8 according to the diagram on page 36.

NOTE Weather stripping tape should be applied in one continuous strip along the length of the roof.

Step 17: Continued

You will need for this page:

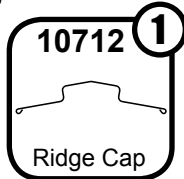
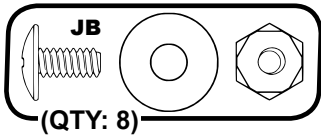

Continue to apply weather stripping.

- 4** Attach Long Ridge Cap with four (4) **Java Bolts** and **Nuts**. DO NOT secure end of **Ridge Caps** until **Peak Caps** are in place.

- Bolts thru Ridge Cap pass thru slots where the Roof Panels overlap with the Panels next to them (labeled ribs #2 and #5 below).

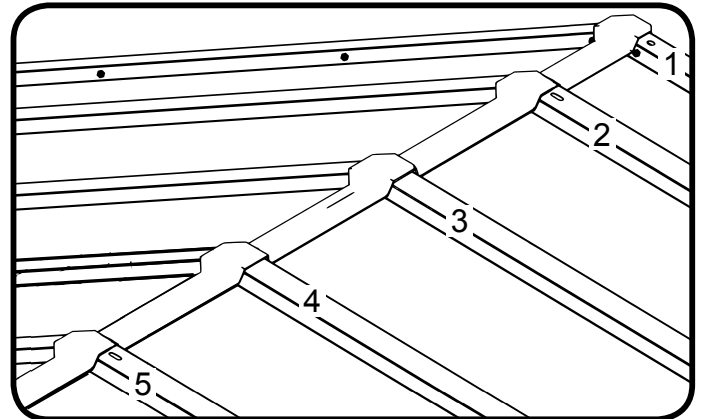

NOTE DO NOT fully tighten Ridge Cap bolts until you have both Ridge Cap bolts in place. This will ease assembly. Bolts must be fully tightened before moving on to the next page.

NOTE Weather Stripping Tape should be applied in a continuous strip along the length of the roof.

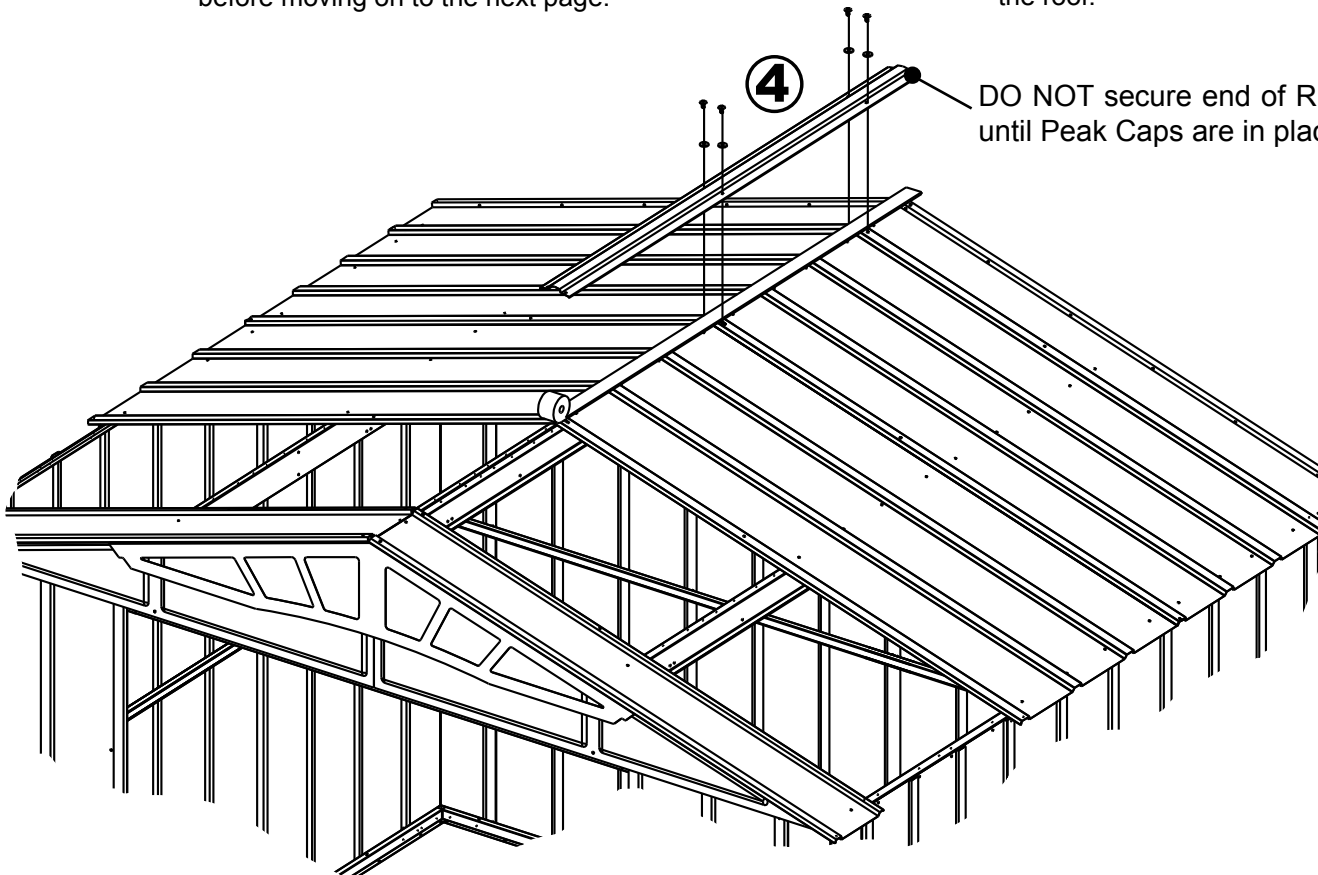

Step 17: Continued

You will need for this page:

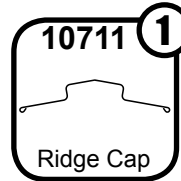
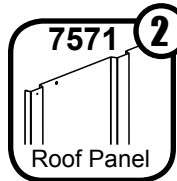
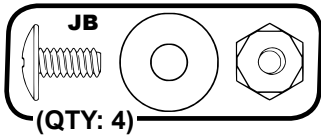
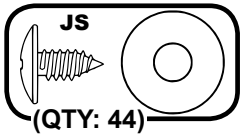

Continue to apply weather stripping.

- ⑤ Install **Roof Panels** #9 and #10.
- ⑥ Finish **Weather Stripping** the roof and cut the tape just past the end of the roof. Fold end of tape under roof edge.
- ⑦ Attach **Short Ridge Cap** with four (4) **Java Bolts** and **Nuts**. DO NOT secure end of **Ridge Caps** until **Peak Caps** are in place.
- ⑧ On both sides of the building, secure the bottom of **Roof Panels** to the **Side Wall Angles** with **Java Screws**.

DO NOT secure end of Ridge Caps until Peak Caps are in place.

NOTE DO NOT fully tighten Ridge Cap bolts until you have both Ridge Cap bolts in place. This will ease assembly. Bolts must be fully tightened before moving on to the next page.

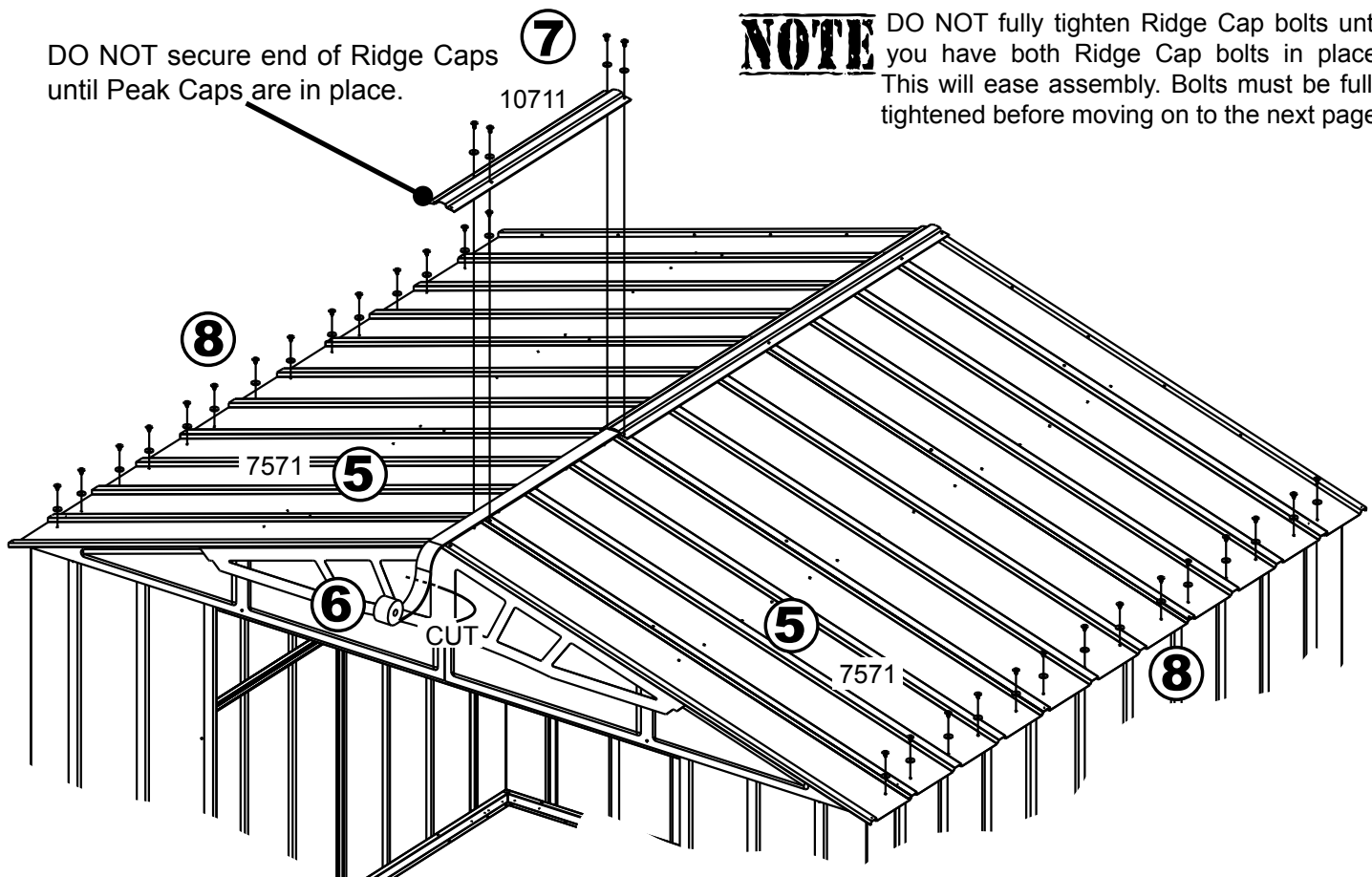

Step 18: Roof Trim

You will need for this page:

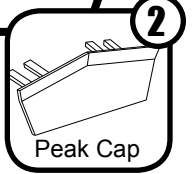
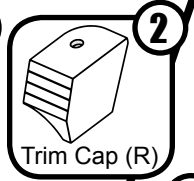
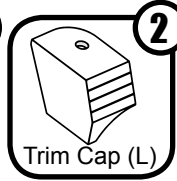
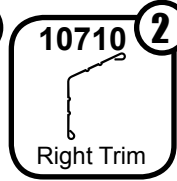
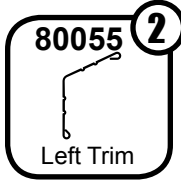
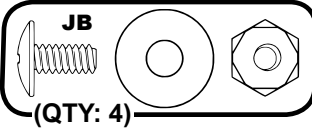
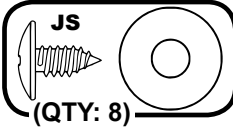
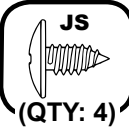

1 Slide **Peak Cap** legs under **Ridge Cap** and secure with two (2) **Java Bolts** and **Nuts** on each end.

2 Position **Roof Trim** as shown below and secure with **Java Screws**. Do not fasten the last screw on each end. Pay close attention to where the **Left** and **Right Roof Trim** pieces are located.

3 Position the **Roof Trim Caps** as shown below and secure with a **Java Screw**.

3 Roof Trim Caps are positioned as shown.

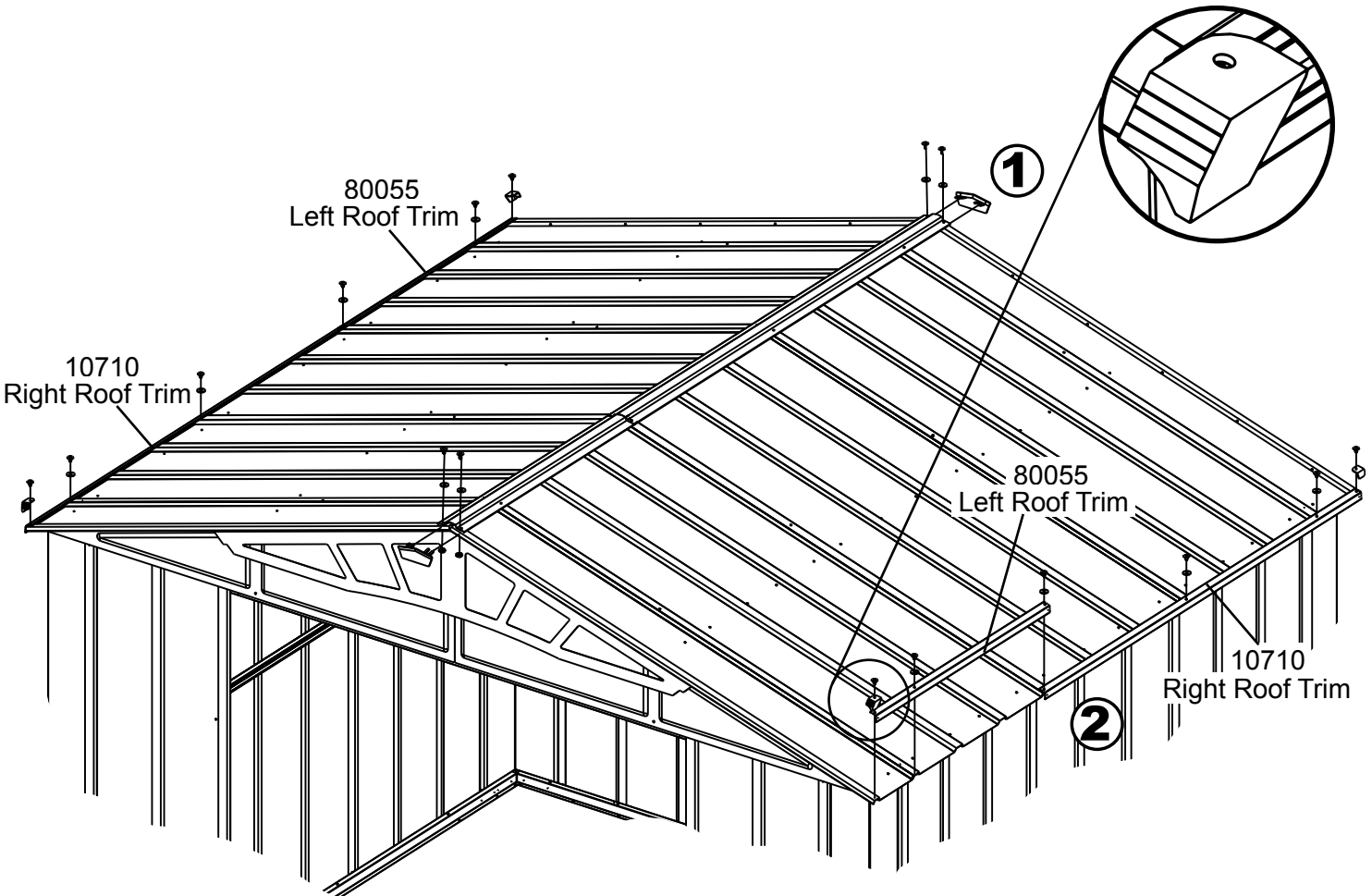

Step 19: Door Installation

You will need for this page:

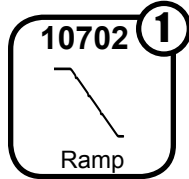
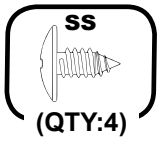
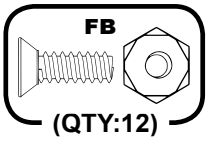

Assemblies from step 5:

- Right Door Assembly (1)
- Left Door Assembly (1)

NEED AT LEAST TWO PEOPLE TO PERFORM THIS STEP!

- 1** Using three (3) Flat Head Bolts and Nuts per Door Hinge, secure Doors to Door Jamb.

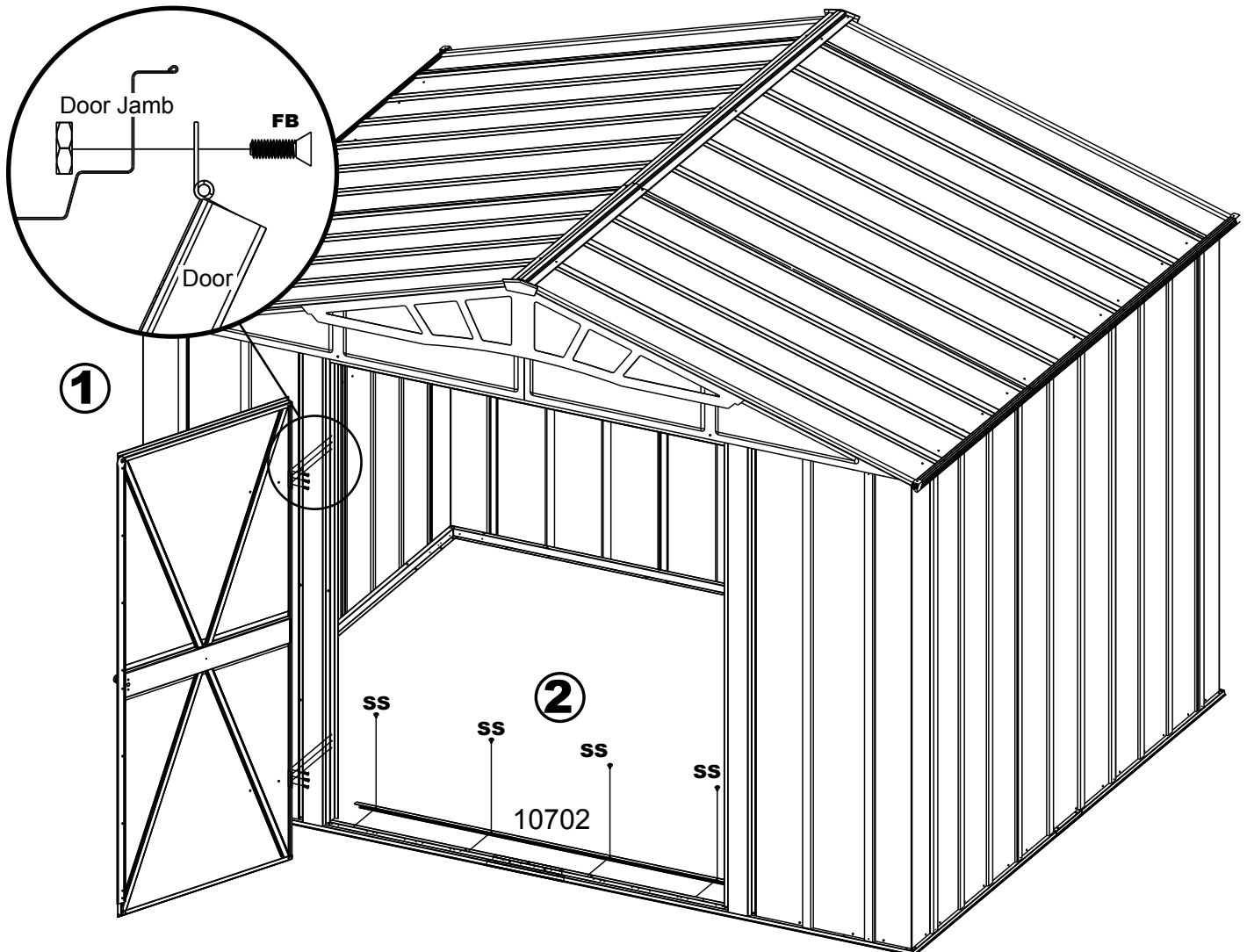

- 2** Fasten Ramp to Floor Frame using four (4) Sand Screws.

ANCHORING OPTIONS...

IMPORTANT:

- *If you have swing doors, they must hang and swing level before anchoring building.*
- *Anchor your building at this time. See below for details on anchoring.*
- *If you have purchased a Floor Frame Kit, you should install it at this time.*
- *Please take a moment to ensure that the building is installed in accordance with these instructions and with all applicable regulations.*

Anchoring Down The Building

The entire floor frame **MUST** be securely anchored once the building is erected.

Below are recommended ways of anchoring.

Arrow Anchoring Kit: (Model No. AK4 or 60298)

Recommended for use with **any** suggested **base**.

Contains: 4 Anchors with Cable, Clamps and installation instructions.

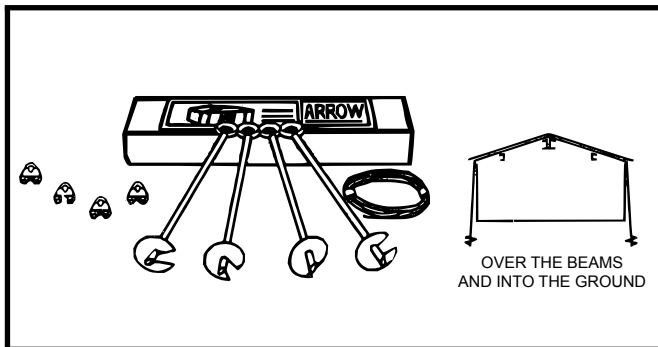

Arrow Anchoring Kit: (Model No. AK100 or 68383)

Recommended for use with the **concrete** base.

Contains: Corner gussets, perimeter clips, hardware, 1/4" masonry drill bit and installation instructions.

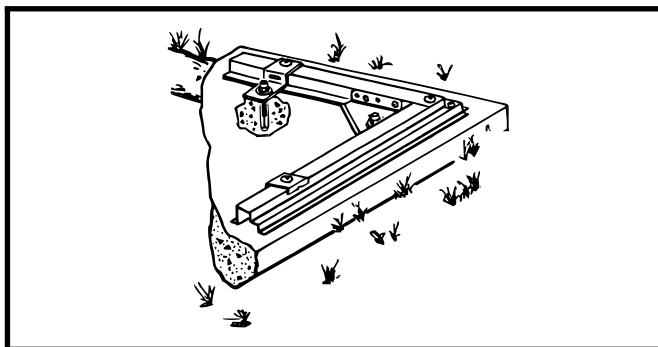

Anchoring into Wood/Post:

Use 1/4" (6 mm) Wood Screws. There are 1/4" (6 mm) dia. holes provided in the frames for proper anchoring.

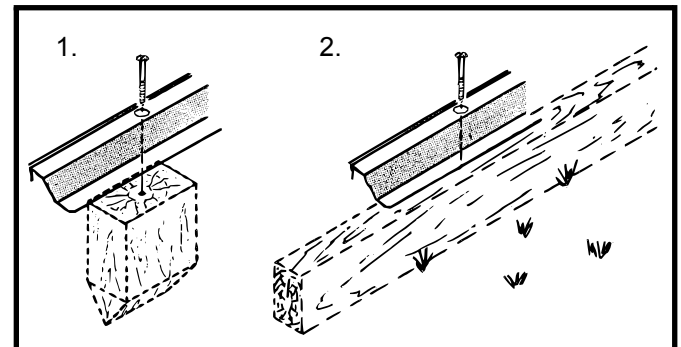

Anchoring into Concrete:

1. For poured concrete slab or footing or patio blocks: Use 1/4" x 2" (6 mm x 51 mm) Lag Screws.
2. For Anchor Post of Concrete poured after building is erected: Use 1/4" x 6" (6 mm x 152 mm) Lag Screws.

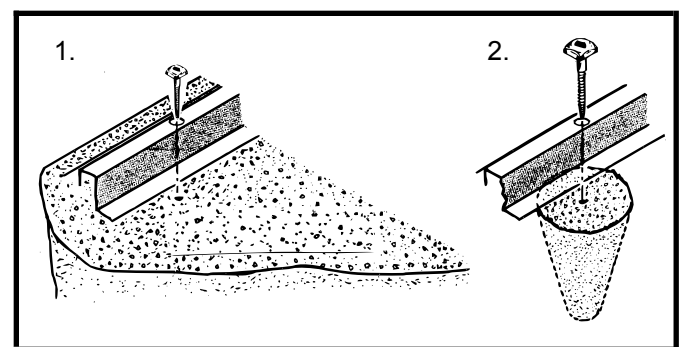

An Anchor Kit may be purchased online at www.arrowsheds.com
 You can also purchase one over the phone by calling 1-800-851-1085.
 See accessories page for details.

CARE & MAINTENANCE...

Exterior Care:

For a long lasting finish, clean and wax the exterior surface. We recommend washing with a mild soap solution. DO NOT use power washing to clean your shed. Using a spray automotive type wax periodically on the exterior is highly recommended if you are in a high humidity or coastal climate region.

Combustibles and corrosives must be stored in air tight containers designed for chemical and/or combustible storage. Corrosive chemicals such as fertilizers, pesticides and herbicides should be cleaned off the interior and exterior surfaces immediately. Rust caused by chemical damage is not covered by the warranty.

DO NOT STORE POOL CHEMICALS IN YOUR SHED - THIS VOIDS YOUR WARRANTY

Rust protection precautions may help to stop rust from developing, or stop it quickly as soon as it appears.

- Avoid nicking or scraping the coating surface, inside and out.
- Keep roof, base perimeter and door tracks free of debris and leaves which may accumulate and retain moisture. These can do double damage since they give off acid as they decay.
- Touch up scrapes or nicks and any area of visible rust as soon as possible. Make sure the surface is free of moisture, oils, dirt or grime and then apply an even film of high quality touch-up paint.
- Various paint manufacturers provide products for rust treatment and coverage. If surface rust does appear on your shed we recommend treating those areas as soon as possible, following the paint supplier of your choice instructions.
- Our customer service department can provide the paint tinting formula for matching the color of your shed. We also have touch-up paint available for repairing small nicks and scratches.

Roof:

Keep the roof clear of leaves and snow. Heavy amounts of snow on the roof can damage the building making it unsafe to enter. In snow country, Roof Strengthening Kits are available for most Arrow Buildings for added protection against heavy snow accumulation.

Doors:

For sliding doors, always keep door tracks clear of dirt and other debris that prevents them from sliding easily. Lubricate door track annually with furniture polish or silicone spray. Keep doors closed and locked to prevent wind damage.

Fasteners:

Use all washers supplied to protect against weather infiltration and to protect the metal from being scratched by the screws. Regularly check screws, bolts, nuts, etc., and retighten as necessary.

General:

- A plastic sheet (vapor barrier) placed under the entire floor area may reduce condensation.
- Wash off inked part numbers on coated panels with soap and water.
- Silicone caulking may be used for watertight seals throughout the building.

Please note, Manufacturer cannot be held responsible for any consequences due to buildings that are not installed per these instructions, or for damage due to weather conditions or acts of God.

Keep these assembly instructions and owner's manual for future reference.

ARROW ACCESSORIES...

ANCHOR KITS

Model No. AK4

Anchor Kit contains heavy-duty steel augers, 60' (18 m) of steel cable and 4 cable clamps. No digging or concrete pouring, just insert cable under roof, over roof beams, into augers and twist augers into the ground. For buildings

larger than 10'x9' (3,0 m x 2,6 m), use 2 kits.

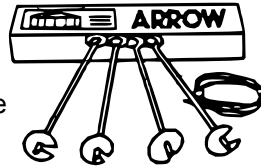

Model No. AK100

New concrete anchor system permits anchoring any size Arrow building directly to a concrete slab. Each kit contains heavy-duty, hot-dipped galvanized steel corner gussets and perimeter clips which fit over the floor frame and lag bolt into a concrete slab. Full assembly instructions and a 1/4" masonry drill bit are included.

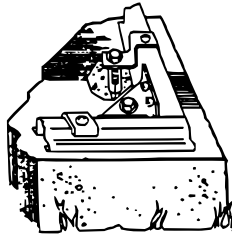

Model No. AK600

Earth Anchor Kit anchors any size Arrow building to the ground. Each kit contains heavy duty, hot-dipped galvanized steel corner gussets and 4 earth anchors.

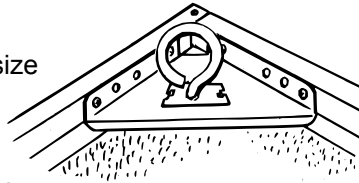

TOOL HANGING RACK

Model No. TH100

The perfect tool organizer. Twin 25 1/2" (64,8 cm) steel channels plus five heavy-duty snap-in hangers and a small tool holder for screwdrivers, pliers, etc. Holders slide along channel for fully adjustable spacing. Great for garage, basement, or the back of any door. Fits all Arrow storage buildings.

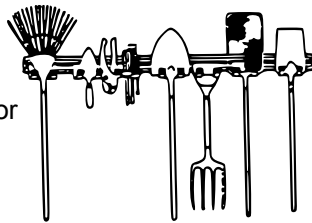

FLOOR FRAME KITS

MODELS FB47410, FB5465, FB106-A, FB109-A, FB1014-A, and FBSDS108

A simple floor frame system made of heavy-duty, hot-dipped galvanized steel. Use as base for plywood, sand or stone.

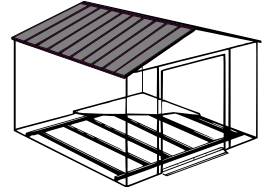

ATTIC KIT / WORKBENCH KIT

Model No. AT101

Heavy-duty galvanized steel bars that fit all 10' (3,0 m) wide Arrow buildings.

They install quickly and easily to help organize space and create more useable space as an attic or workbench. Will hold up to 250 lbs. (113 kg) evenly distributed.

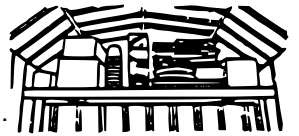

Some drilling required to fit buildings without mid-wall bracing.

SHELF UNITS

Heavy-duty, galvanized steel shelf units help organize storage space. They easily mount on the wall or sit on the floor. Fits all Arrow buildings.*

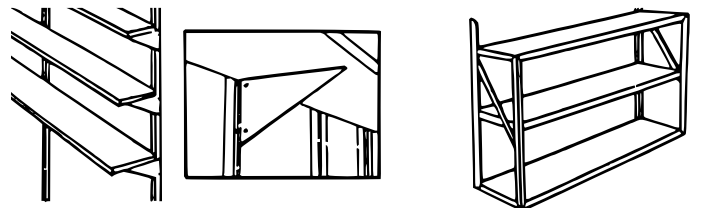

Model No. SS404

- Makes 8" to 12" (20,3-30,5 cm) wide shelves in any length.
- Brackets, braces, hardware included.
- Lumber is not included.

Model No. SS900-A

- Grey color
- 3 shelves
- Holds up to 85 lbs. (38 kg) (even weight distribution)

* Some drilling required to fit buildings without mid-wall bracing.

HOW TO ORDER

We recommend that you purchase accessory items from your local storage building dealer whenever possible; however, because the full line of accessories is not always available from all dealers, Arrow is offering them to you on a direct basis.

Purchase Online at www.arrowsheds.com

Purchase over the phone by calling 1-800-851-1085

Most major credit cards accepted. Allow 2 weeks for Delivery.

SPECIAL NOTICE ON DELIVERY:

If your accessory is shipped via truck line a day time phone number is required to arrange delivery. If no one is available to sign for the delivery, you may be subject to a re-delivery charge assessed by the carrier.

ASSEMBLY NOTES

ASSEMBLY NOTES

